

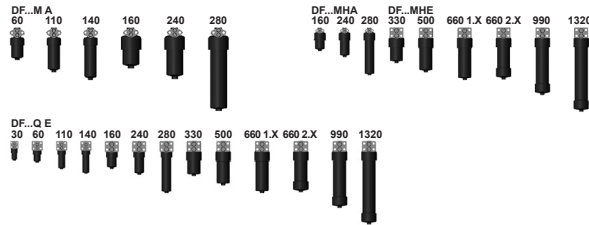

## Pressure Filter DF...M A, DF...Q E, DF...MHA, DF...MHE Flange Mounted up to 550 l/min, up to 315 bar



### 1. TECHNICAL SPECIFICATIONS

#### 1.1 FILTER HOUSING Construction

The filter housings are designed in accordance with international regulations. They consist of a filter head and a screw-in filter bowl.

Standard equipment:

- mounting holes in the filter head
- two-piece bowl for size DF...990 and above (optional for size DF...660 and above)
- drain screw with pressure relief (standard for size DF...330 and above)

#### 1.2 FILTER ELEMENTS

HYDAC filter elements are validated and their quality is constantly monitored according to the following standards:

- ISO 2941
- ISO 2942
- ISO 2943
- ISO 3724
- ISO 3968
- ISO 11170
- ISO 16889

Filter elements are available with the following pressure stability values:

Optimicon® (ON):	20 bar
Betamicon® (BH4HC):	210 bar
Optimicon® Pulse (ON/PS):	20 bar
Optimicon® Pulse (OH/PS):	210 bar
Wire mesh (W/HC):	20 bar
Stainless steel fibre (V):	210 bar

### 1.3 FILTER SPECIFICATIONS

Nominal pressure	DF...M A/MHA/MHE: 250 bar DF...Q E: 315 bar
Fatigue strength	10 <sup>6</sup> cycles (DF...M A/DF...Q E) 10 <sup>8</sup> cycles (DF...MHA/DF...MHE) from 0 to nominal pressure (for other pressures, see graph, Point 1.8)
Temperature range	-10 °C to +100 °C (-30 °C to -10 °C: p <sub>max</sub> = 0.5 x nom. press.)
Material of filter head	EN-GJS-400-15 (DF...M A/DF...Q E) ADI (DF...MHA/DF...MHE)
Material of filter bowl	Steel
Type of clogging indicator	VD (differential pressure measurement up to 420 bar operating pressure)
Pressure setting of the clogging indicator	5 bar (others on request)
Cracking pressure of bypass (optional)	6 bar (only DF...M A / Q E)

### 1.4 SEALS

NBR (=Perbunan)

### 1.5 INSTALLATION

Pressure filter for flange mounting

### 1.6 SPECIAL MODELS AND ACCESSORIES

- Bypass valve built into the head, separate from the main flow
- Seals in FPM, EPDM
- Test and approval certificates

### 1.7 SPARE PARTS

See Original Spare Parts List

### 1.8 FATIGUE STRENGTH

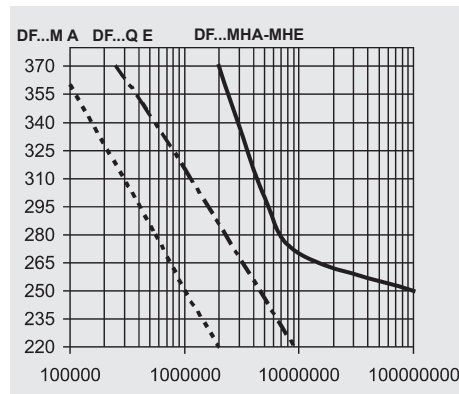

### 1.9 CERTIFICATES AND APPROVALS on request

### 1.10 COMPATIBILITY WITH HYDRAULIC FLUIDS ISO 2943

- Hydraulic oils H to HLPD DIN 51524
- Lubrication oils DIN 51517, API, ACEA, DIN 51515, ISO 6743
- Compressor oils DIN 51506
- Biodegradable operating fluids VDMA 24568 HETG, HEES, HEPG
- Fire-resistant fluids HFA, HFB, HFC and HFD
- Operating fluids with high water content (>50% water content) on request

### Symbol for hydraulic systems

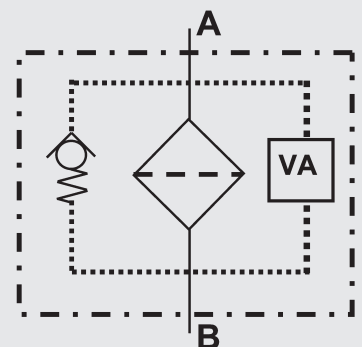

VA = clogging indicator

## 2. MODEL CODE (also order example)

DF ON 240 M H A 10 D 1 X /-L24

### 2.1. COMPLETE FILTER

#### Filter type

DF... flange mounted

#### Filter material

ON	Optimicron®	ON/PS	Optimicron® Pulse
BH/HC	Betamicron® (BH4HC)	OH/PS	Optimicron® Pulse
W/HC	Stainl. st. wire mesh		
V	Stainless steel fibre		

#### Size of filter or element

M A: 60, 110, 140, 160, 240, 280  
 Q E: 30, 60, 110, 140, 160, 240, 280, 330, 500, 660, 990, 1320  
 MHA: 160, 240, 280  
 MHE: 330, 500, 660, 990, 1320

#### Operating pressure

M = 250 bar  
 Q = 315 bar

#### Application

No details: 10<sup>6</sup> cycles  
 H: high duty cycle, 10<sup>8</sup> cycles (only for DF...MHA / DF...MHE)

#### Type and size of connection

A 2 mounting holes  
 E 4 mounting holes

#### Filtration rating in µm

ON: 1, 3, 5, 10, 15, 20  
 BH/HC, ON/PS, OH/PS, V: 3, 5, 10, 20  
 W/HC: 25, 50, 100, 200

#### Type of clogging indicator

Y	plastic blanking plug in indicator port	] for other clogging indicators see brochure no. 7.050../..
A	steel blanking plug in indicator port	
B	visual	
C	electrical	
D	visual and electrical	

#### Type code

1 model with one-piece filter bowl (up to size 660)  
 2 model with two-piece filter bowl (size 660 and above)

#### Modification number

X the latest version is always supplied

#### Supplementary details

B.	bypass cracking pressure (e.g. B6 = 6 bar); only possible for DF...M A / DF...Q E	] only for clogging indicators type "D"
L...	light with appropriate voltage (24, 48, 110, 220 Volt)	
LED	2 light emitting diodes up to 24 Volt	
OAI	outlet above inlet (only for DF...160, 240, 280 Q E)	
SO184	pressure release/oil drain screw (only DF...60-240)	
SO348	for operating pressure $p_{max} \leq 210$ bar (type of clogging indicator = VM)	
V	FPM seals	
W	suitable for HFA and HFC emulsions	

### 2.2 REPLACEMENT ELEMENT

0240 D 010 ON /-V

#### Size

0030, 0060, 0110, 0140, 0160, 0240, 0280, 0330, 0500, 0660, 0990, 1320

#### Type

D

#### Filtration rating in µm

ON 001, 003, 005, 010, 015, 020  
 BH4HC, ON/PS, OH/PS, V: 003, 005, 010, 020  
 W/HC: 025, 050, 100, 200

#### Filter material

ON, BH4HC, ON/PS, OH/PS, V, W/HC

#### Supplementary details

V, W (for descriptions, see point 2.1)

### 2.3 REPLACEMENT CLOGGING INDICATOR

VD 5 D X /-L24

#### Type

VD Differential pressure indicator up to 420 bar operating pressure  
 VM Differential pressure indicator up to 210 bar operating pressure (only in conjunction with SO348)

#### Pressure setting

5 standard 5 bar, others on request

#### Type of clogging indicator

D (see Point 2.1)

#### Modification number

X the latest version is always supplied

#### Supplementary details

L..., LED, V, W (for descriptions, see point 2.1)

### 3. FILTER CALCULATION / SIZING

The total pressure drop of a filter at a certain flow rate Q is the sum of the housing  $\Delta p$  and the element  $\Delta p$  and is calculated as follows:

$$\Delta p_{\text{total}} = \Delta p_{\text{housing}} + \Delta p_{\text{element}}$$

$$\Delta p_{\text{housing}} = (\text{see Point 3.1})$$

$$\Delta p_{\text{element}} = Q \cdot \frac{SK^*}{1000} \cdot \frac{\text{viscosity}}{30}$$

(\*see Point 3.2)

For ease of calculation, our Filter Sizing Program is available on request free of charge.

**NEW:** Sizing online at [www.hydac.com](http://www.hydac.com)

#### 3.1 $\Delta p$ -Q HOUSING CURVES BASED ON ISO 3968

The housing curves apply to mineral oil with a density of 0.86 kg/dm<sup>3</sup> and a kinematic viscosity of 30 mm<sup>2</sup>/s. In this case, the differential pressure changes proportionally to the density.

**DF 60, 110, 140 M A**

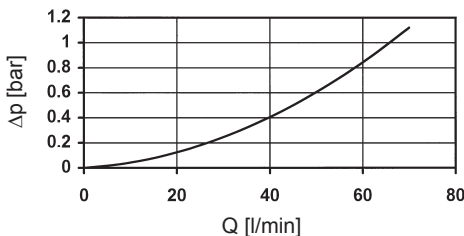

**DF 160, 240, 280 M A / MHA**

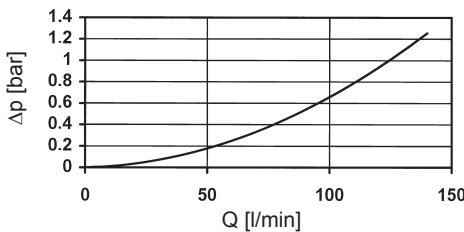

**DF 30 Q E**

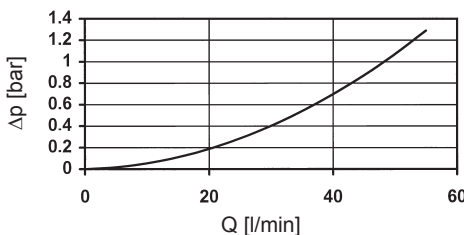

**DF 60, 110, 140 QE**

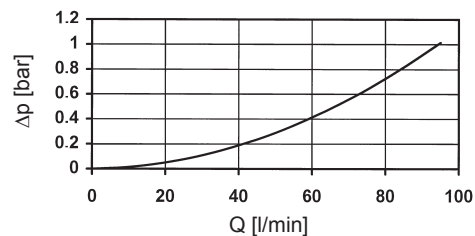

**DF 160, 240, 280 Q E (also /-OAI)**

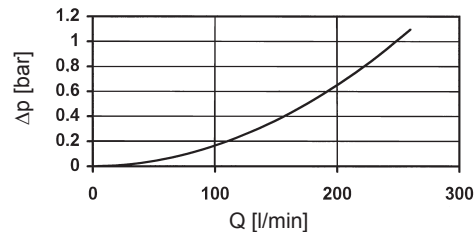

**DF 330, 500, 660, 990, 1320 Q E / MHE**

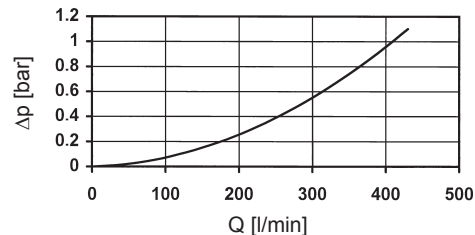

### 3.2 GRADIENT COEFFICIENTS (SK) FOR FILTER ELEMENTS

The gradient coefficients in mbar/(l/min) apply to mineral oils with a kinematic viscosity of 30 mm<sup>2</sup>/s. The pressure drop changes proportionally to the change in viscosity.

DF...	ON					
	1 µm	3 µm	5 µm	10 µm	15 µm	20 µm
30	77.8	63.9	43.3	22.8	14.0	11.3
60	53.5	26.0	18.3	12.1	9.78	6.32
110	25.8	13.4	9.61	6.06	4.63	2.99
140	19.9	11.5	7.39	4.38	3.54	2.29
160	18.5	11.0	7.70	4.10	3.71	3.18
240	11.5	6.90	5.34	3.19	2.44	2.10
280	5.54	3.37	2.74	1.49	1.36	1.17
330	8.23	4.19	3.37	2.46	1.55	1.22
500	5.05	2.57	2.07	1.23	0.95	0.75
660	3.78	1.93	1.56	0.93	0.71	0.56
990	2.51	1.28	1.03	0.61	0.47	0.37
1320	1.85	0.97	0.76	0.45	0.35	0.27

DF...	ON/PS				OH/PS			
	3 µm	5 µm	10 µm	20 µm	3 µm	5 µm	10 µm	20 µm
30	63.90	43.30	25.08	11.30	87.54	59.32	34.36	15.48
60	28.90	20.40	14.52	7.90	39.59	27.95	19.89	10.82
110	14.90	10.70	7.26	3.70	20.41	14.66	9.95	5.07
140	12.80	8.20	5.28	2.90	17.54	11.23	7.23	3.97
160	13.10	8.80	5.52	3.50	17.95	12.06	7.56	4.80
240	8.20	6.10	4.32	2.30	11.23	8.36	5.92	3.15
280	4.00	3.10	2.04	1.30	5.48	4.25	2.79	1.78
330	4.86	3.90	3.00	1.70	6.66	5.34	4.11	2.33
500	2.97	2.40	1.50	1.10	4.07	3.29	2.06	1.51
660	2.25	1.80	1.10	0.80	3.08	2.47	1.51	1.10
990	1.44	1.20	0.70	0.50	1.97	1.64	0.96	0.69
1320	1.10	0.90	0.50	0.40	1.51	1.23	0.69	0.55

DF...	V				W/HC	BH4HC			
	3 µm	5 µm	10 µm	20 µm		3 µm	5 µm	10 µm	20 µm
30	18.4	13.5	7.5	3.6	3.030	91.2	50.7	36.3	19.0
60	16.0	9.3	5.4	3.3	0.757	58.6	32.6	18.1	12.2
110	8.2	5.6	3.3	2.2	0.413	25.4	14.9	8.9	5.6
140	5.8	4.8	3.1	2.3	0.324	19.9	11.3	8.1	4.3
160	4.6	3.2	2.3	1.4	0.284	16.8	10.4	5.9	4.4
240	3.1	2.5	1.7	1.1	0.189	10.6	6.8	3.9	2.9
280	2.3	1.7	1.2	0.8	0.162	5.7	3.4	1.8	1.6
330	2.2	1.8	1.2	0.8	0.138	7.7	4.5	2.8	2.0
500	1.5	1.2	0.8	0.5	0.091	4.2	2.6	1.5	1.2
660	1.1	0.9	0.6	0.4	0.069	3.3	1.9	1.0	0.9
990	0.8	0.6	0.4	0.3	0.046	2.2	1.3	0.8	0.6
1320	0.6	0.5	0.3	0.2	0.035	1.6	1.0	0.6	0.4

## 4. DIMENSIONS

DF... MA: BG 60 - 280  
DF... MHA: BG 160 - 280

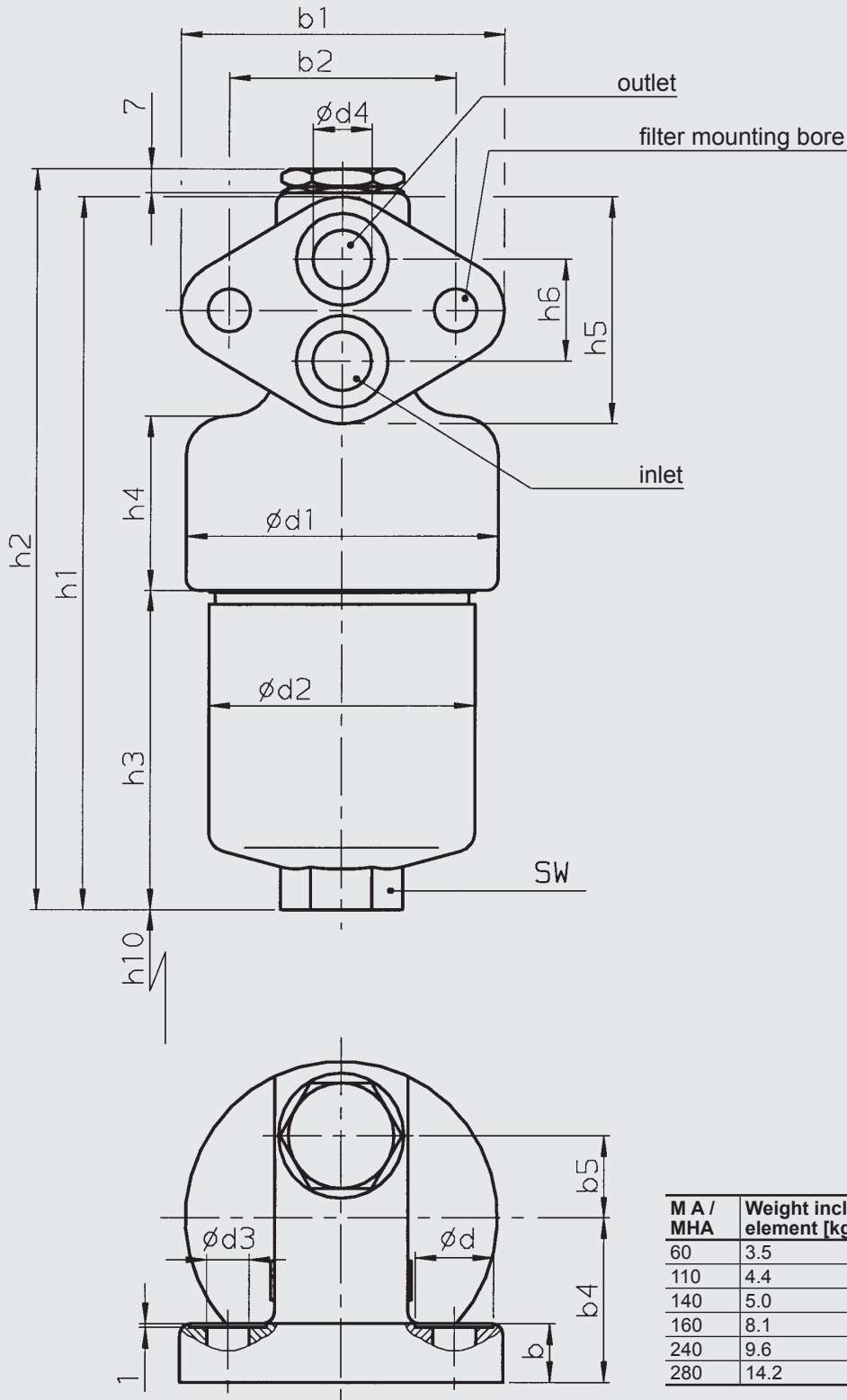

MA / MHA	Weight incl. element [kg]	Vol. of pressure chamber [l]
60	3.5	0.20
110	4.4	0.33
140	5.0	0.40
160	8.1	0.60
240	9.6	0.80
280	14.2	1.60

MA / MHA	b	b1	b2	b3	b4	b5	d	d1	d2	d3	d4	d5	h1	h2	h3	h4	h5	h6	h7	h8	h9	h10	h11	SW	O-ring <sup>1)</sup>
60	15	83	58	-	42	21	20	80	68	11	15	-	185	192	83	45	58	26	-	-	-	75	-	27	19 x 2.5
110	15	83	58	-	42	21	20	80	68	11	15	-	252.5	259.5	150.5	45	58	26	-	-	-	75	-	27	19 x 2.5
140	15	83	58	-	42	21	20	80	68	11	15	-	296	303	194	45	58	26	-	-	-	75	-	27	19 x 2.5
160	20	83	58	-	60	26	20	116	95	13.5	15	-	232	239	107	79	58	26	-	-	-	85	-	32	19 x 2.5
240	20	83	58	-	60	26	20	116	95	13.5	15	-	292	299	167	79	58	26	-	-	-	85	-	32	19 x 2.5
280	20	83	58	-	60	26	20	116	95	13.5	15	-	474	481	349	79	58	26	-	-	-	85	-	32	19 x 2.5

1) supplied

DF... Q E: BG 30 - 1320  
 DF... MHE: BG 330 - 1320

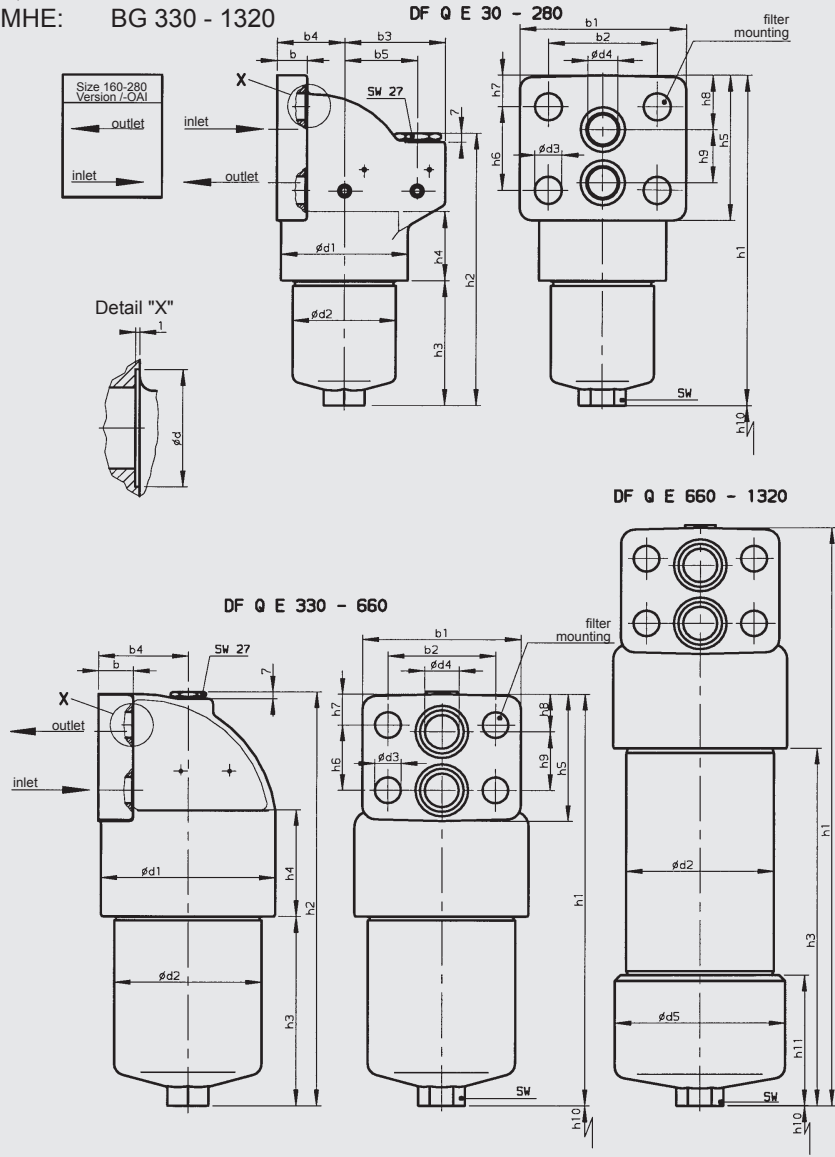

Q E / MHE	Weight incl. element [kg]	Vol. of pressure chamber [l]
30	2.9	0.13
60	5.2	0.20
110	6.1	0.33
140	6.7	0.40
160 <sup>3)</sup>	12.3	0.60
240 <sup>3)</sup>	13.7	0.80
280 <sup>3)</sup>	18.1	1.60
330	22.9	1.50
500	27.3	2.30
660	30.9	3.00
660 <sup>2)</sup>	34.1	3.00
990 <sup>2)</sup>	42.1	4.20
1320 <sup>2)</sup>	50.3	5.60
Q E /-OAI	Weight incl. element [kg]	Vol. of pressure chamber [l]
160	10.7	0.60
240	12.7	0.80
280	17.0	1.60

Q E / MHE	b	b1	b2	b3	b4	b5	d	d1	d2	d3	d4	d5	h1	h2	h3	h4	h5	h6	h7	h8	h9	h10	h11	SW	O-ring <sup>1)</sup>
30	18	80	57	56	37	38	20	67	52	13	14	-	197	176	78	48	76	45	15.5	30.5	28	75	-	24	18 x 2.5
60	20	110	72	66	45	48	26	84	68	18	20	-	217	181	83	45.5	94	55	19.5	34.5	35	75	-	27	24 x 3
110	20	110	72	66	45	48	26	84	68	18	20	-	284	248	150	45.5	94	55	19.5	34.5	35	75	-	27	24 x 3
140	20	110	72	66	45	48	26	84	68	18	20	-	328	292	194	45.5	94	55	19.5	34.5	35	75	-	27	24 x 3
160 <sup>3)</sup>	30	140	95	100	59	79	32	116	95	22	32	-	280	222	117	61	110	60	25	31	52	85	-	32	40 x 3.5
240 <sup>3)</sup>	30	140	95	100	56	79	32	116	95	22	32	-	340	282	177	61	110	60	25	31	52	85	-	32	40 x 3.5
280 <sup>3)</sup>	30	140	95	100	59	79	32	116	95	22	32	-	522	464	359	61	110	60	25	31	52	85	-	32	40 x 3.5
330	30	140	95	-	79.5	-	32	154	130	23	30	-	353	357	157	94	110	58	26	32	52	115	-	36	40 x 3.5
500	30	140	95	-	79.5	-	32	154	130	23	30	-	446	450	250	94	110	58	26	32	52	115	-	36	40 x 3.5
660	30	140	95	-	79.5	-	32	154	130	23	30	-	523	527	329	94	110	58	26	32	52	115	-	36	40 x 3.5
660 <sup>2)</sup>	30	140	95	-	79.5	-	32	154	132	23	30	152	517	521	321	94	110	58	26	32	52	350	112	36	40 x 3.5
990 <sup>2)</sup>	30	140	95	-	79.5	-	32	154	132	23	30	152	673	677	477	94	110	58	26	32	52	500	112	36	40 x 3.5
1320 <sup>2)</sup>	30	140	95	-	79.5	-	32	154	132	23	30	152	839	843	643	94	110	58	26	32	52	670	112	36	40 x 3.5
Q E /-OAI	b	b1	b2	b3	b4	b5	d	d1	d2	d3	d4	d5	h1	h2	h3	h4	h5	h6	h7	h8	h9	h10	h11	SW	O-ring <sup>1)</sup>
160	30	140	95	83	84	59	32	116	95	22	32	-	284	239	119	64	110	58	26	31	52	85	-	32	40 x 3.5
240	30	140	95	83	84	59	32	116	95	22	32	-	344	299	179	64	110	58	26	31	52	85	-	32	40 x 3.5
280	30	140	95	83	84	59	32	116	95	22	32	-	526	481	361	64	110	58	26	31	52	85	-	32	40 x 3.5

<sup>1)</sup> supplier / <sup>2)</sup> two-piece bowl version / <sup>3)</sup> not OAI

**NOTE**

The information in this brochure relates to the operating conditions and applications described.  
 For applications or operating conditions not described, please contact the relevant technical department.  
 Subject to technical modifications.

**HYDAC Filtrertechnik GmbH**  
 Industriegebiet  
**D-66280 Sulzbach/Saar**  
 Tel.: 0 68 97 / 509-01  
 Fax: 0 68 97 / 509-300  
 Internet: www.hydac.com  
 E-Mail: filter@hydac.com