

KKD

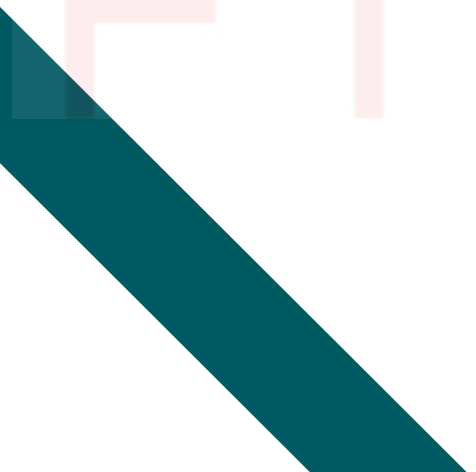

















































PIUSI
®

MADE IN ITALY







































FILTER



FUEL PRODUCT RANGE

PRODUCT RANGE	PRODUCT CATEGORY	PRODUCT	PAGE
DISPENSERS 	ATEX	 EX50 DRUM 	8
		 EX100 / EX140 DRUM 	10
		 EX50 ST 	12
	CUBE	 CUBE	14
		 CUBE MC	16
		 CUBE MC 2.0	18
	DRUM	 DRUM	20
		 PICO	22
	MOBILE	 BATTERY KIT	24
		 PITSTOP	26
		 PIUSIBOX	28
	SELF SERVICE	 SELF SERVICE K44	30
		 SELF SERVICE MC	32
		 SELF SERVICE MC 2.0	34
		 SELF SERVICE FM	36
		 SELF SERVICE FM 2.0	38
	ST	 ST	40
		 ST WITH METER	42
		 ST WITH METER AND FILTER	44
		 ST BOX	46
 ST 200 AC		48	
 ST 200 DC		50	
PUMPS 	ATEX	 EX50 	58
		 EX75 	60
		 EX100 / EX140 NAKED 	62
	AC PUMPS	 PANTHER AC	64
		 VISCOMAT VANE	66
		 E80 / E120	68
		 E140	70
		 E300	72
	DC PUMPS	 BP3000	74
		 CARRY	76
		 PANTHER DC	78
		 BIPUMP	80
	HAND PUMPS	 PIUSI HAND PUMP	82
 HAND PUMPS		84	
METERS	ATEX	 K33 ATEX 	90
		 K24 ATEX 	92
	ELECTRONIC METERS	 K24	94
		 K600/3	96
		 K600 B/3	98

All Pictures shown are for illustration purpose only. Actual product may vary due to product enhancement.

PRODUCT RANGE	PRODUCT CATEGORY	PRODUCT	PAGE
	MECHANICAL METERS	 K600/4	100
		 K700 PULSER	102
		 K900	104
		 REMOTE DISPLAY	106
		 K33 / K44	108
		 K700	110
NOZZLES 	ATEX	 A60 ATEX 	116
	AUTOMATIC NOZZLES	 A60 / A80 / A120	118
	MANUAL NOZZLE	 A280	120
		 SELF 2000 / SELF 3000	122
FILTRATION 	FILTERING SYSTEM	 FILTROLL	126
	FILTERS	 WATER CAPTOR	128
		 CLEAR CAPTOR	130
		 FUEL&BIOFUEL	132
		 FOOT VALVE	134
FLUID MONITORING 	TANK LEVEL INDICATORS	 OCIO	138
		 OCIO 2.0	140
	ACCESS CONTROL	 ACCESS85	142
	MC BOX	 MC BOX	144
		 MC BOX 2.0	146
	SOFTWARE	 SSM2018	148
		 DATA TRANSFER SSM2018	150
		 SSM2.0	152
	 DATA TRANSFER SSM2.0	154	
HOSE REELS 	OPEN	 DIESEL HOSE REEL	160
ACCESSORIES 	CONNECTORS		166
	COUPLING&FITTINGS		168
	FLANGED CONNECTIONS		170
	HOSE&SWIVEL		172
MERCHANDISE 	MERCHANDISE		176

JOURNEY

THE HISTORY OF
KNOW-HOW

ABOUT US

PIUSI was established in 1953 in Suzzara, in the province of Mantua (Italy). For more than 60 years, PIUSI has been the major player in the world's leading markets with its full range of products for transferring, refilling and measuring lubricants, fuels and liquids such as gasoline, diesel, Diesel Exhaust Fluid (DEF), oil, water and grease. Some of PIUSI's main products include pumps, flow meters, nozzles, dispensers, hose reels, liquid level gauges, software and complete kits used by operators in agriculture, the automotive industry, workshops and garages, fleet management and transport by road and by sea. PIUSI products have many different uses such as monitoring and transferring fuel at trucking companies, refueling of agricultural vehicles, transferring fuels in construction and mining for heavy duty vehicles. The products are intuitive and easy to use; are suitable to be installed in a variety of contexts; are all made entirely in Italy; and all products express the innovation, quality, professionalism and R&D that have always distinguished PIUSI. Its headquarters are in Suzzara (Mantova - 150 km from Milan and Venice). The company currently employs more than 250 employees between sales, administration, R&D, production and logistics. PIUSI products are sold in more than 120 countries around the world thanks to a large network of distributors and the US branch based in Fort Lauderdale, FL, serving the North and South American markets.

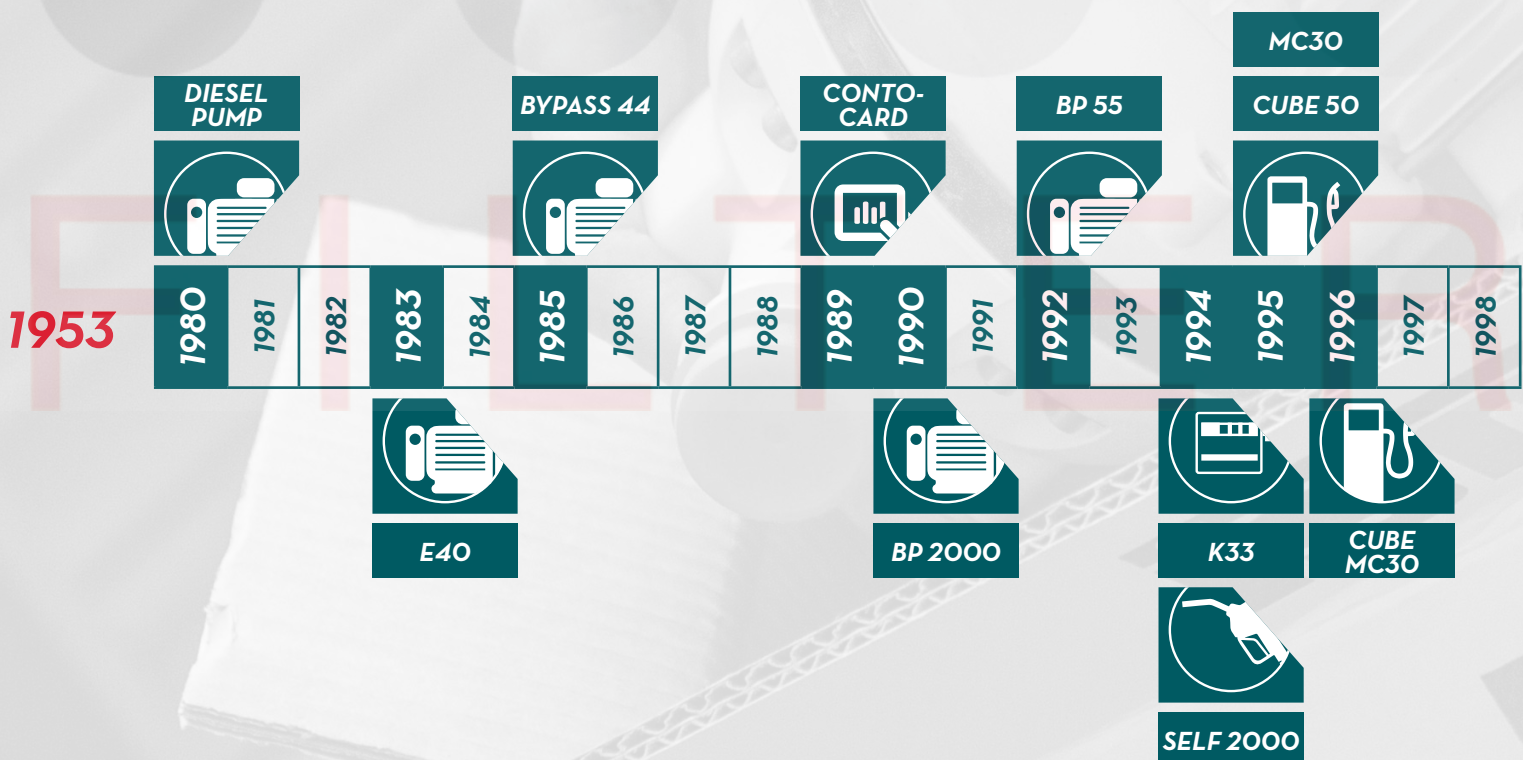

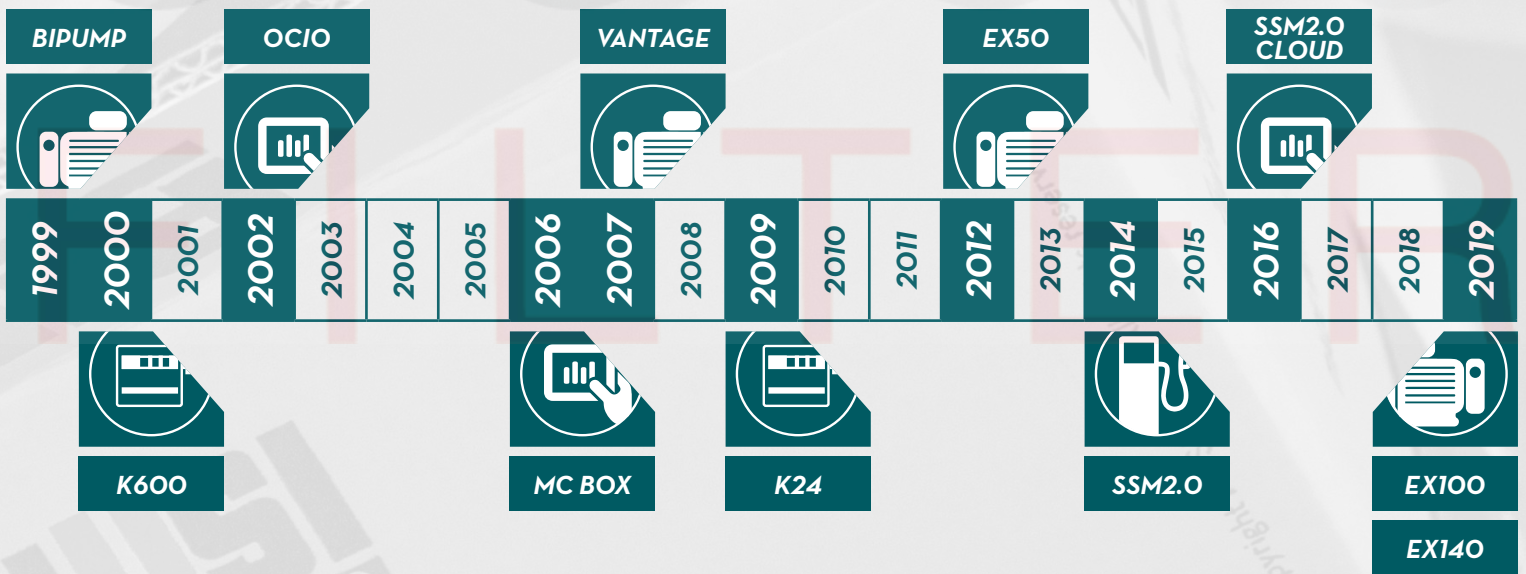



KKD

DISPENSERS

FILTER



DISPENSERS



PUMPS



METERS



NOZZLE



FILTRATION



FLUID MONITORING

EX50 DRUM

FEATURES

- STURDY STRUCTURE
- FLANGED COMPONENTS
- ANTI-NOISE FILTER
- THERMAL PROTECTION
- BUILT-IN BYPASS VALVE
- SUCTION PIPE WITH INTEGRATED FILTER
- UL LISTED VERSION AVAILABLE

The PIUSI EX50 DRUM is a complete pump transfer kit expressly engineered for ATEX/IECEx areas. This system is composed of a high-efficiency pump, manual or automatic nozzle and a telescopic suction hose. Thanks to the flanged components, this transfer set allows users to replace any component without using sealants thus creating maximum versatility and adaptability to any kind of condition. K33 mechanical meter available on request.



PIUSI DRUM EX50 WITH METER AND FILTER



PERFORMANCE

UP TO
50 L/MIN

FLOW RATE

1100 MM

SUCTION PIPE

200β/30μ

FILTERING CAPACITY

± 1%

ACCURACY



DRUM EX50 WITH AUTOMATIC NOZZLE



DRUM EX50 WITH MANUAL NOZZLE

OUR PUMPS COMPLIES WITH THE FOLLOWING MARKING ATEX/IECEx

II	2	G	Ex	d	IIA	T4	Gb
GROUP	CATEGORY	TYPE OF EXPLOSIVE ATMOSPHERE	PERMANENT PREFIX	PROTECTION METHOD	GAS GLASS	TEMPERATURE CLASS	EQUIPMENT PROTECTION LEVEL

PACKAGING

CODE	WEIGHT		PACKAGING		
	KG	LBS	MM	INCH	PCS/BOX
WITHOUT METER					
FO0372000	10	22	600X400X290	23,6X13,7X11,4	1
FO0372010	10	22	600X400X290	23,6X13,7X11,4	1
FO0372020	79	17,4	345X175X225	-	1
FO0372030	10	22	600X400X290	23,6X13,7X11,4	1
FO0372040	10	22	600X400X290	23,6X13,7X11,4	1
FO037400A	10	22	600X400X290	23,6X13,7X11,4	1
FO037401A	10	22	600X400X290	23,6X13,7X11,4	1
FO037402A	79	17,4	345X175X225	-	1
WITH METER					
FO037500A	12	22	600X400X290	23,6X13,7X11,4	1
FO037501A	12	22	600X400X290	23,6X13,7X11,4	1
FO037502A	12	22	600X400X290	23,6X13,7X11,4	1
FO037503A	12	22	600X400X290	23,6X13,7X11,4	1
FO037600B	12	22	600X400X290	23,6X13,7X11,4	1
FO037601B	12	22	600X400X290	23,6X13,7X11,4	1





HOSE REELS



ACCESSORIES



MERCHANDISE



AIR



ANTIFREEZE



AdBlue®



BIODIESEL



DIESEL



FOOD



GASOLINE



GREASE



KEROSENE



OIL



WATER



WINDSCREEN

CHART**IN THE BOX**

- EX50 PUMP
- TELESCOPIC SUCTION PIPE
- DELIVERY HOSE
- WATER CAPTOR FILTER
- NOZZLE
- 2" CONNECTOR
- K33 MECHANICAL METER (ON REQUEST)
- INSTRUCTION MANUAL

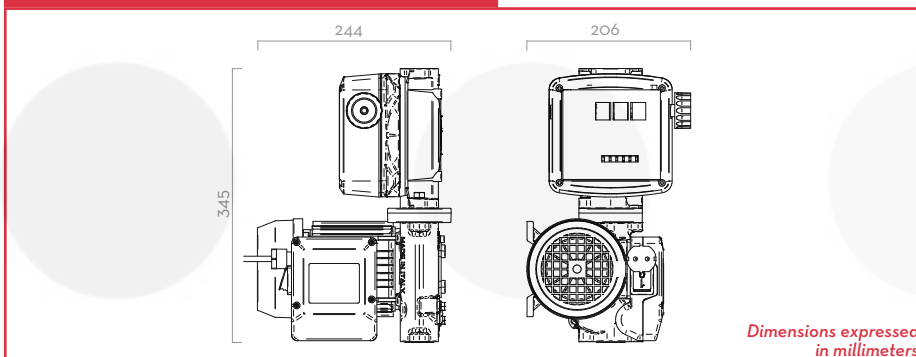
DETAILS**DIMENSIONS****COMPONENTS**

- **PUMP:**
EX50 PAG. 58
- **METER:**
K33 ATEX PAG. 90
- **NOZZLE:**
A60 ATEX PAG. 116
SELF3000 PAG. 122
- **FILTER:**
WATER CAPTOR PAG. 128

TECHNICAL DATA

CODE	DESCRIPTION	FLUIDS TYPE	FLOW-RATE		VOLTAGE			METER	NOZZLE	FILTER	INLET	HOSE	
			L/MIN	GPM	AC V/HZ	DC VOLT	POWER WATT					AMP. MAX.	TYPE
WITHOUT METER													
FO0372000	DRUM EX50 12V DC ATEX + MAN. NOZZLE	D G K	50	13	12	250	21	-	MAN.	YES	1"	4	3/4"
FO0372010	DRUM EX50 12V DC ATEX + AUT. NOZZLE	D G K	50	13	12	250	21	-	AUT.	YES	1"	4	3/4"
FO0372020	KIT DRUM EX50 12V DC ATEX	D G K	50	13	12	250	21	-	NO	NO	1"	-	-
FO0372030	DRUM EX50 12V DC ATEX + MAN. NOZZLE + CABLE	D G K	50	13	12	250	21	-	MAN.	YES	1"	4	3/4"
FO0372040	DRUM EX50 12V DC ATEX + AUT. NOZZLE + CABLE	D G K	50	13	12	250	21	-	AUT.	YES	1"	4	3/4"
FO037400A	DRUM EX50 230V DC ATEX + MAN. NOZZLE	D G K	50	13	230/50-60	250	1	-	MAN.	YES	1"	4	3/4"
FO037401A	DRUM EX50 230V DC ATEX + AUT. NOZZLE	D G K	50	13	230/50-60	250	1	-	AUT.	YES	1"	4	3/4"
FO037402A	KIT DRUM EX50 230V AC ATEX*	D G K	50	13	230/50-60	250	1	-	NO	NO	1"	-	-
WITH METER													
FO037500A	DRUM EX50 12V DC K33 ATEX + MAN. NOZZLE	D G K	50	13	12	250	21	K33	MAN.	YES	1"	4	3/4"
FO037501A	DRUM EX50 12V DC K33 ATEX + AUT. NOZZLE	D G K	50	13	12	250	21	K33	AUT.	YES	1"	4	3/4"
FO037502A	DRUM EX50 12V DC K33 ATEX + MAN. NOZZLE + CABLE	D G K	50	13	12	250	21	K33	MAN.	YES	1"	4	3/4"
FO037503A	DRUM EX50 12V DC K33 ATEX + AUT. NOZZLE + CABLE	D G K	50	13	12	250	21	K33	AUT.	YES	1"	4	3/4"
FO037600B	DRUM EX50 230V DC K33 ATEX + MAN. NOZZLE	D G K	50	13	230/50-60	250	1	K33	MAN.	YES	1"	4	3/4"
FO037601B	DRUM EX50 230V DC K33 ATEX + AUT. NOZZLE	D G K	50	13	230/50-60	250	1	K33	AUT.	YES	1"	4	3/4"

(*) UPON REQUEST IT IS AVAILABLE WITH DIFFERENT VOLTAGES AND 60 HZ FREQUENCY.
COMPATIBLE FLUIDS: DIESEL, KEROSENE, PETROL, PETROL ALCOHOL MIXED MAX 15%, AVGAS 100/100LL, JET A/A1 - ASPEN 2/4



DISPENSER



PUMPS



METERS



NOZZLE



FILTRATION



FLUID MONITORING

EX100 / EX140 DRUM

FEATURES

- CONTINUOUS DUTY
- THERMAL PROTECTION
- SUCTION UNIT WITH INTEGRATED FILTER
- UL VERSION AVAILABLE
- HIGH FLOW RATE

The entire new EX line is characterized by a high flow rate that works with a continuous duty cycle, and has been designed to be particularly suitable for Heavy Duty, i.e. for those demanding fleets that need to dispense fuels such as Gasoline, diesel or kerosene quickly.



EX140



PERFORMANCE

UP TO
140 L/MIN

FLOW RATE

AC
VOLTAGE

POWER



EX100

OUR PUMPS COMPLIES WITH THE FOLLOWING MARKING ATEX/IECEx

II	2	G	Ex	d	IIA	T4	Gb
GROUP	CATEGORY	TYPE OF EXPLOSIVE ATMOSPHERE	PERMANENT PREFIX	PROTECTION METHOD	GAS GLASS	TEMPERATURE CLASS	EQUIPMENT PROTECTION LEVEL

PACKAGING

CODE	WEIGHT		PACKAGING		
	KG	LBS	MM	INCH	PCS/BOX
WITHOUT METER					
FO0391010	25	55	240X400X390	10X16X15	1
FO0391020	25	55	240X400X390	10X16X15	1
FO0396010	25	55	240X400X390	10X16X15	1
FO0396020	25	55	240X400X390	10X16X15	1
FO0396030	25	55	240X400X390	10X16X15	1



HOSE REELS



ACCESSORIES



MERCHANDISE



AIR



ANTIFREEZE



AdBlue®



BIODIESEL



DIESEL



FOOD



GASOLINE



GREASE



KEROSENE



OIL



WATER



WINDSCREEN

CHART

EX100 / EX140 DRUM

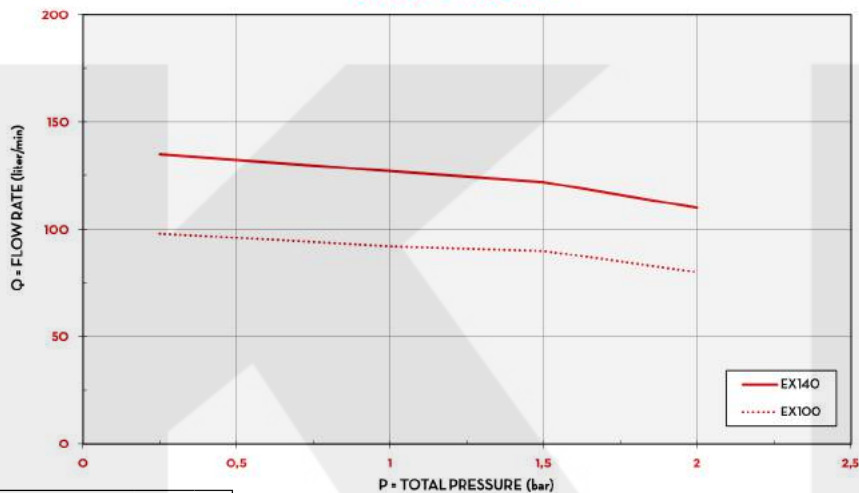

TYPE OF FLUID DIESEL

TEMPERATURE 20 °C

IN THE BOX

- EX100 / EX140 PUMPS
- NOZZLE HOLDER
- 1" 1/4 CONNECTOR
- 90° ELBOW
- FILTER (ON SELECTED VERSION)
- METER (ON SELECTED VERSION)
- AUTOMATIC NOZZLE (ON SELECTED VERSION)
- INSTRUCTION MANUAL

DETAILS



MESH STRAINER



1" 1/4 CONNECTOR



90° ELBOW

DIMENSIONS

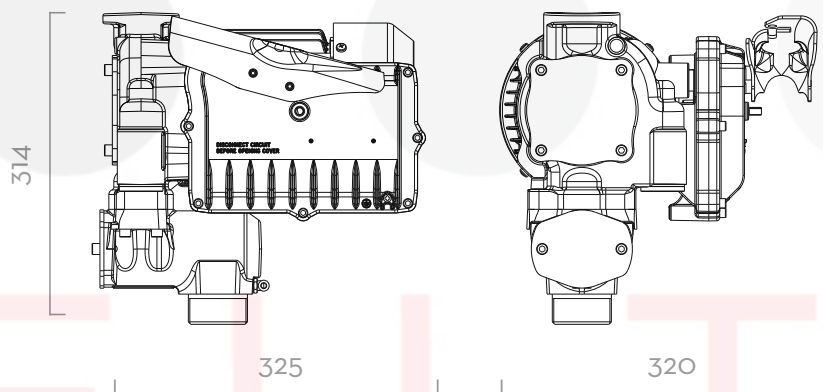

Dimensions expressed in millimeters

MATERIALS

- BODY: CAST IRON
- ROTOR: SINTERED STEEL
- VANES: TECHNOPOLYMER
- SEAL: VITON
- SHAFT: STEEL

TECHNICAL DATA

CODE	DESCRIPTION	FLUIDS TYPE	FLOW-RATE		VOLTAGE			DUTY CICLE	RPM	INLET		OUTLET	
			L/MIN	GPM	AC V/HZ	DC VOLT	POWER WATT			AMP. MAX.	CONTINUOUS	BSP	BSP
WITHOUT METER													
FO0391010	(EX) GRUPPO DRUM EX100 230V/50	D G K	100	25	230/50	1035	4,5	YES	1450	1" 1/4	1"		
FO0391020	(EX) GRUPPO DRUM EX100 230V/60	D G K	100	25	230/60	874	3,8	YES	1750	1" 1/4	1"		
FO0396010	(EX) GRUPPO DRUM EX140 230V/50	D G K	140	37	230/50	1150	5	YES	1450	1" 1/4	1"		
FO0396020	(EX) GRUPPO DRUM EX140 250V/50	D G K	140	37	250/50	1125	4,5	YES	1450	1" 1/4	1"		
FO0396030	(EX) GRUPPO DRUM EX140 230V/60	D G K	140	37	230/60	920	4	YES	1750	1" 1/4	1"		

(*) UPON REQUEST IT IS AVAILABLE WITH DIFFERENT VOLTAGES AND 60 HZ FREQUENCY. COMPATIBLE FLUIDS: DIESEL, KEROSENE, PETROL, PETROL ALCOHOL MIXED MAX 15%, AVGAS 100/100LL, JET A/A1 - ASPEN 2/4

EX100/EX140 DRUM



DISPENSERS



PUMPS



METERS



NOZZLE



FILTRATION



FLUID MONITORING

EX50 ST

FEATURES

- **STURDY STRUCTURE**
- **COMPACT, VERSATILE**
- **EASY TO INSTALL**
- **ANTI-NOISE FILTER**
- **OVERLOAD PROTECTION**

The PIUSI EX50 ST is a sturdy and compact transfer station equipped with an ACEX/IECEX certified pump suitable for the transfer of all flammable liquids. These transfer stations are the final solution for all applications in which mobile or underground tanks need to be equipped with a dispenser unit. Thanks to the flanged components, this transfer set allows users to replace any component without using sealants.



PERFORMANCE

UP TO
50 L/MIN

FLOW RATE

AC
VOLTAGE
POWER

± 1%

ACCURACY

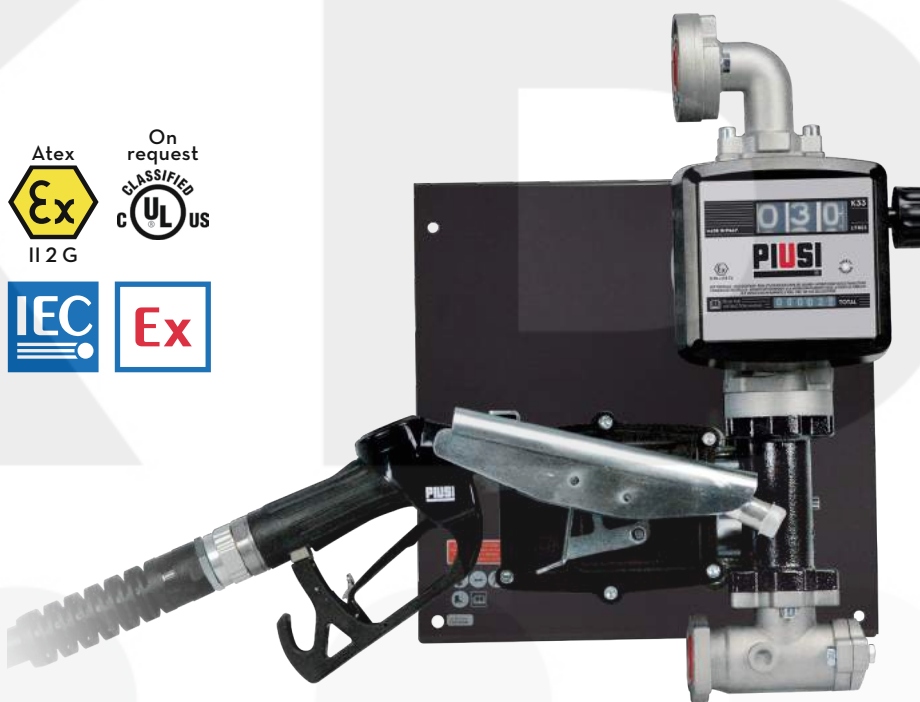

PIUSI ST EX50 WITH METER AND NOZZLE



OUR PUMPS COMPLY WITH THE FOLLOWING MARKING ATEX/IECEX

II	2	G	Ex	d	IIA	T4	Gb
GROUP	CATEGORY	TYPE OF EXPLOSIVE ATMOSPHERE	PERMANENT PREFIX	PROTECTION METHOD	GAS GLASS	TEMPERATURE CLASS	EQUIPMENT PROTECTION LEVEL

PACKAGING

CODE	WEIGHT		PACKAGING		
	KG	LBS	MM	INCH	PCS/BOX
WITH METER					
FO0377000	12	24,5	600X400X290	23,6X13,7X11,4	1



HOSE REELS



ACCESSORIES



MERCHANDISE



AIR



ANTIFREEZE



AdBlue®



BIODIESEL



DIESEL



FOOD



GASOLINE



GREASE



KEROSENE



OIL



WATER



WINDSCREEN

CHART



IN THE BOX

- METALLIC PLATE
- EX50 PUMP
- TELESCOPIC SUCTION HOSE
- GASOLINE HOSE
- FILTER
- NOZZLE
- 2" CONNECTOR
- K33 MECHANICAL METER (ON REQUEST)
- INSTRUCTION MANUAL

COMPONENTS' DETAILS



NUTATING DISK SYSTEM



MESH STRAINER

DIMENSIONS

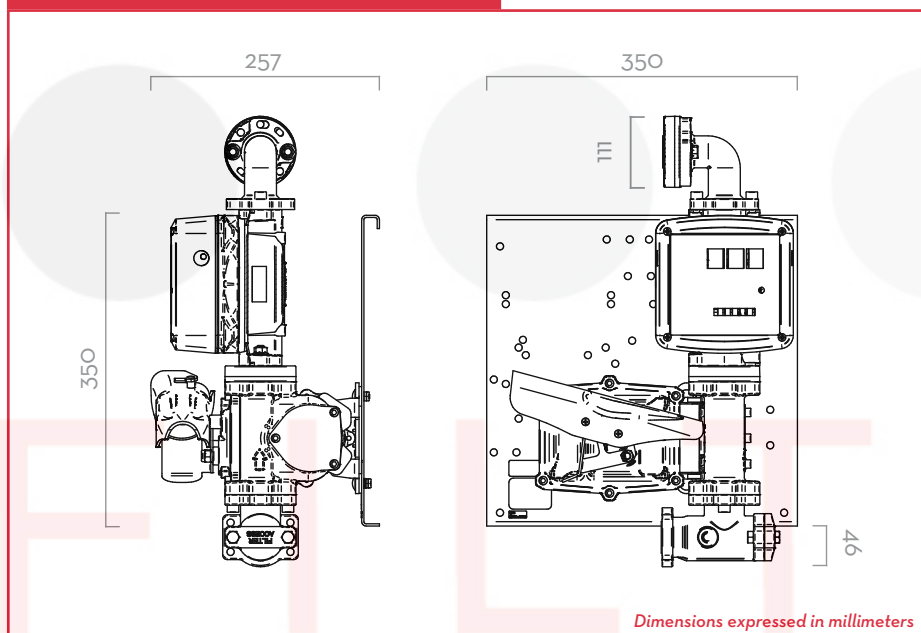

COMPONENTS

- **PUMP:**
EX50 PAG. 58
- **METER:**
K33 ATEX PAG. 90
- **NOZZLE:**
A60 ATEX PAG. 116

TECHNICAL DATA

CODE	DESCRIPTION	FLUIDS TYPE	FLOW-RATE		VOLTAGE			METER	NOZZLE	FILTER	INLET BSP	HOSE	
			L/MIN	GPM	AC V/HZ DC VOLT	POWER WATT	AMP. MAX.	TYPE	TYPE			LENGTH MM	Ø BSP
FO0377000	ST EX50 230V K33 ATEX + AUT. NOZZLE	D G K	50	13	230/50-60	250	21	K33	AUT.	-	1"	4	3/4"

(*) UPON REQUEST IT IS AVAILABLE WITH DIFFERENT VOLTAGES AND 60 HZ FREQUENCY.

COMPATIBLE FLUIDS: DIESEL, KEROSENE, PETROL, PETROL ALCOHOL MIXED MAX 15%, AVGAS 100/100LL, JET A/A1 - ASPEN 2/4



DISPENSERS



PUMPS



METERS



NOZZLE



FILTRATION



FLUID MONITORING

CUBE

FEATURES

- **STURDY STRUCTURE**
- **MECHANICAL METER**
- **INDUCTION THERMAL-PROTECTED MOTOR**
- **OVERLOAD PROTECTION**
- **BUILT-IN MESH FILTER**
- **IP 55**

The PIUSI CUBE is a range of mechanical fuel transfer dispenser for non-commercial use, composed of a self-priming vane pump fitted with integrated bypass valve, automatic nozzle with swivel connection and integrated nozzle holder with start/stop pump lever. Its versatility allows different applications: on walls, on tanks, on cisterns, on drums or stand-alone (with the optional pedestal).

PERFORMANCE

UP TO
90 L/MIN

FLOW-RATE

AC/DC

VOLTAGE
POWER

± 1%

ACCURACY



CUBE 56 WITH FILTER



CUBE 56 WITH PEDESTAL (optional)

PACKAGING

CODE	WEIGHT		PACKAGING			N. BOXES / EUROPALET	
	KG	LBS	MM	INCH	PCS/BOX		
00057500C	21	46	400X400X460	-	1	12	24
00057516A	21	46	400X400X460	-	1	12	24
FO059100A	21	46	400X400X460	-	1	12	24
FO059111A	21	46	400X400X460	-	1	12	24
FO057600C	21	46	400X400X460	-	1	12	24
FO057700C	21	46	400X400X460	-	1	12	24
FO0575400	22	46	400X400X460	-	1	12	24
FO0591200	22	48	400X400X460	-	1	12	24
FO0592000	22	46	400X400X460	-	1	12	24



HOSE REELS



ACCESSORIES



MERCHANDISE



AIR



ANTIFREEZE



AdBlue®



BIODIESEL



DIESEL



FOOD



GASOLINE



GREASE



KEROSENE



OIL



WATER



WINDSCREEN

CHART

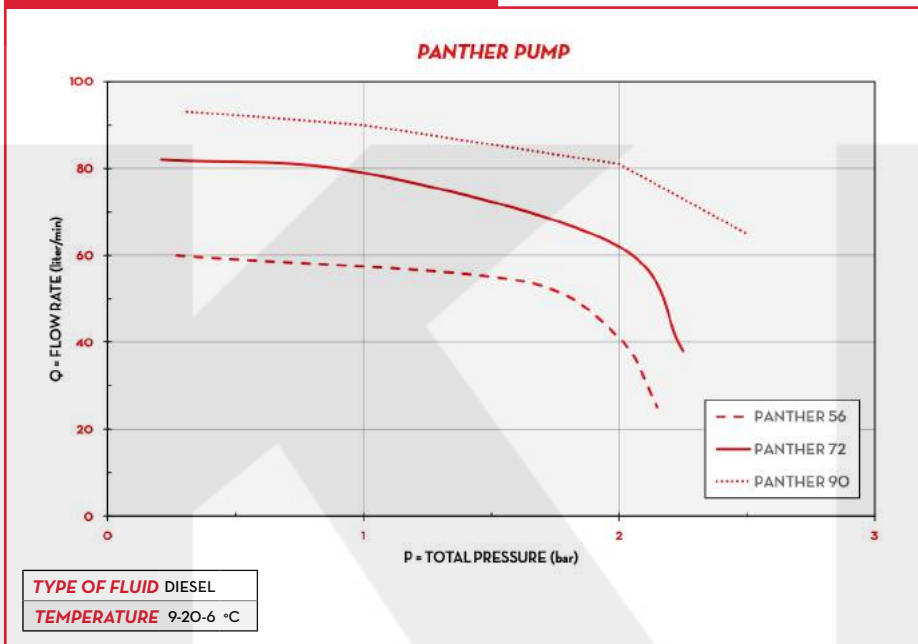

IN THE BOX

- CUBE DISPENSER
- AUTOMATIC NOZZLE
- DELIVERY HOSE
- INSTRUCTION MANUAL

DETAILS



NUTATING DISK METER



K33/K44 (pag. 108)

DIMENSIONS

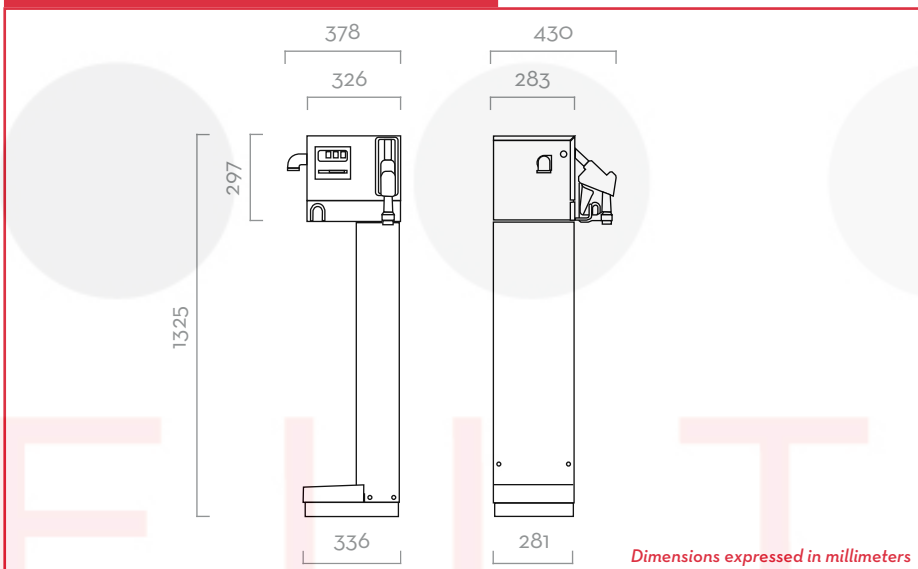

COMPONENTS

- **PUMP:**
PANTHER AC PAG. 64
PANTHER DC PAG. 78
- **METER:**
K33 / K44 PAG. 108
- **NOZZLE:**
AUTOMATIC NOZZLE PAG. 118

TECHNICAL DATA

CODE	DESCRIPTION	FLUIDS TYPE	FLOW-RATE		VOLTAGE			PUMP	METER	NOZZLE	FILTER		INLET	HOSE	
			L/MIN	GPM	AC V/ HZ	DC VOLT	POWER WATT				AMP. MAX.	H2O FILTER		FILTERING CAPACITY	BSP
00057500C	CUBE 56	D	56	15	230/50	350	3	PANTH 56	K33	AUT.	NO	-	1"	4M	3/4"
00057516A	CUBE 56/44 PULSER	D	56	15	230/50	350	3	PANTH 56	K44	AUT.	NO	-	1"	4M	3/4"
FO059100A	CUBE 70/33	D	70	18	230/50	500	4,2	PANTH 72	K33	AUT.	NO	-	1"	4M	1"
FO059111A	CUBE 70/44 PULSER	D	70	18	230/50	500	4,2	PANTH 72	K44	AUT.	NO	-	1"	4M	1"
FO057600C	CUBE 56 DC 12V	D	56	15	12	300	35	PANTH DC	K33	AUT.	NO	-	1"	4M	1"
FO057700C	CUBE 70 DC 24V	D	70	18	24	420	25	PANTH DC	K33	AUT.	NO	-	1"	4M	3/4"
FO0575400	CUBE 56/33 + FILTER	D	56	15	230/50	350	3	PANTH 56	K33	AUT.	YES	30 µ	1"	6M	3/4"
FO0591200	CUBE 70/33 + FILTER	D	70	18	230/50	500	4,2	PANTH 72	K33	AUT.	YES	30 µ	1"	6M	1"
FO0592000	CUBE 90/44	D	90	23,8	230/50	700	4,9	PANTH 90	K44	A120	NO	-	1"	4M	1"

UPON REQUEST IT IS AVAILABLE WITH DIFFERENT VOLTAGES AND 50/60 HZ FREQUENCY



DISPENSERS



PUMPS



METERS



NOZZLE



FILTRATION



FLUID MONITORING

CUBE MC

FEATURES

- MULTI-USER MANAGEMENT
- ALL-IN-ONE EQUIPMENT
- COMPACT DESIGN
- COMPATIBLE WITH SSM 2018 SOFTWARE
- SUCTION FILTER
- IP55

The PIUSI CUBE MC is the upgraded version of the world famous Cube dispenser equipped with an electronic panel able to manage up to 120 users and 255 transactions. The sturdy structure includes a self-priming vane pump, built-in bypass, automatic nozzle, and integrated nozzle holder with start/stop pump lever.

PERFORMANCE

UP TO
70 L/MIN

FLOW-RATE

AC/DC

VOLTAGE

POWER

± 0,5%

ACCURACY

UP TO
120

USERS



CUBE 70 MC



CUBE 70 MC WITH PEDESTAL (optional)

PACKAGING

CODE	WEIGHT		PACKAGING			N. BOXES / EUROPALET	
	KG	LBS	MM	INCH	PCS/BOX	✈	🚚
FO059400D	25	55	400X400X460	-	1	12	24
FO059413C	25	55	400X400X460	-	1	12	24
FO059414C	25	55	400X400X460	-	1	12	24
FO059415C	25	55	400X400X460	-	1	12	24
FO059422A	25	55	400X400X460	-	1	12	24



HOSE REELS



ACCESSORIES



MERCHANDISE



AIR



ANTIFREEZE



AdBlue®



BIODIESEL



DIESEL



FOOD



GASOLINE



GREASE



KEROSENE



OIL



WATER

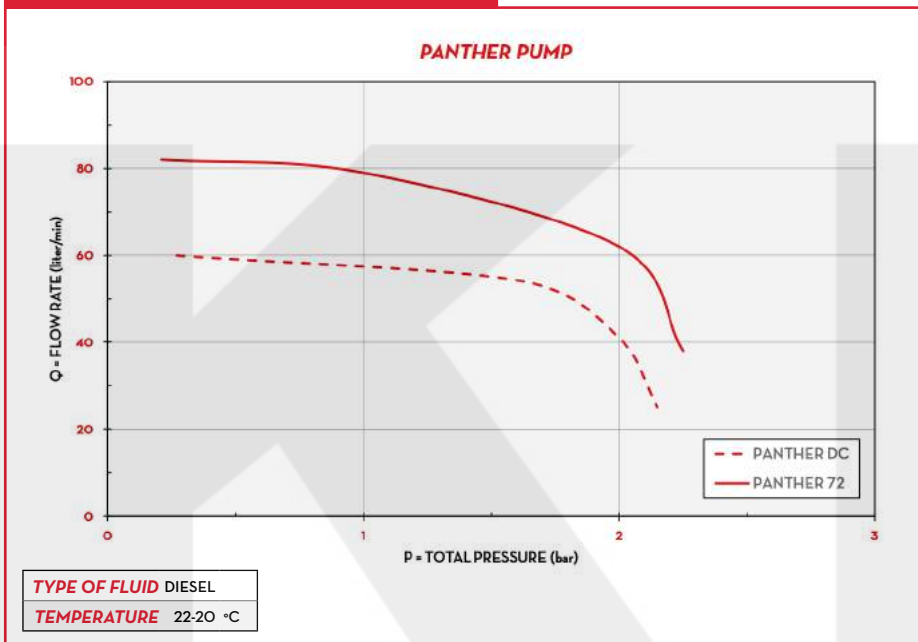

WINDSCREEN

CHART**IN THE BOX**

- CUBE DISPENSER
- AUTOMATIC NOZZLE
- DELIVERY HOSE
- INSTRUCTION MANUAL

DETAILS

SHUTTER

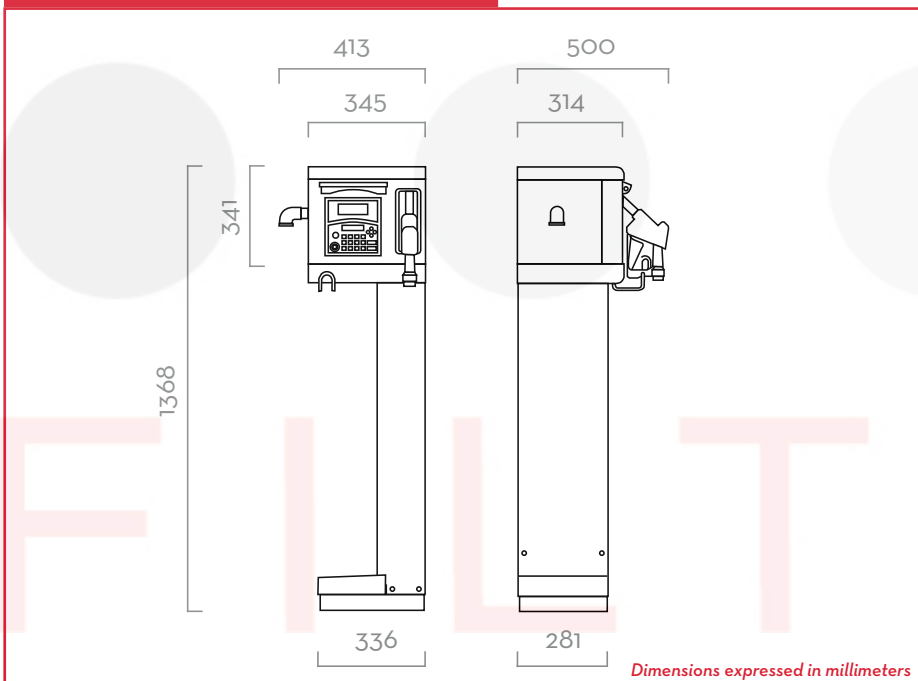

DRIVER KEY (not included)

DIMENSIONS

DATA TRANSFER 2018 (pag. 150)



SSM 2018 (pag. 148)

MATERIALS

- **PUMPS:**
PANTHER AC PAG. 64
PANTHER DC PAG. 78
- **METER:**
K600/3 PAG. 96
- **NOZZLE:**
AUTOMATIC NOZZLE PAG. 118

TECHNICAL DATA

CODE	DESCRIPTION	FLUIDS TYPE	FLOW-RATE		VOLTAGE			PUMP	METER	NOZZLE	FILTER	INLET	HOSE		PC	USERS
			L/MIN	GPM	AC V./HZ	DC VOLT	POWER WATT						AMP. MAX.	TYPE		
FO059400D	CUBE 70 MC	D	70	18	230/50	900	4,2	PANTH 72	K600	AUT.	NO	1"	4M	1"	YES	50
FO059413C	CUBE 70 MC DC 12V	D	56	15	12	300	35	PANTH DC	K600	AUT.	NO	1"	4M	1"	YES	50
FO059414C	CUBE 70 MC DC 24V	D	70	18	24	420	25	PANTH DC	K600	AUT.	NO	1"	4M	1"	YES	50
FO059415C	CUBE 70 MC 120 UT	D	70	18	230/50	550	3,3	PANTH 72	K600	AUT.	NO	1"	4M	1"	YES	120
FO059422A	CUBE 70 MC 12V 120 UT	D	56	15	12	300	35	PANTH DC	K600	A120	NO	1"	4M	1"	YES	120

UPON REQUEST IT IS AVAILABLE WITH DIFFERENT VOLTAGES AND 60 HZ FREQUENCY



DISPENSERS



PUMPS



METERS



NOZZLE



FILTRATION



FLUID MONITORING

CUBE MC 2.0

FEATURES

- **STURDY STRUCTURE**
- **BUILT-IN LAN ADAPTER**
- **COMPACT DESIGN**
- **SSM 2.0 SOFTWARE REQUIRED**
- **IP55**
- **IDEAL FOR FUEL MANAGEMENT**

The PIUSI CUBE MC 2.0 is the perfect solution for those who need safe and simple, high-volume fuel dispensing operations while checking transactions and managing their own fleet. The system is equipped with the same main feature of the CUBE MC System, and includes a built-in LAN connection. SSM 2.0 Software required.

PERFORMANCE

UP TO
90 L/MIN

FLOW-RATE

AC
CONTINUOUS DUTY

POWER

± 0,5%

ACCURACY



CUBE MC 2.0



CUBE MC 2.0 WITH PEDESTAL (optional)

PACKAGING

CODE	WEIGHT		PACKAGING			N. BOXES / EUROPALET	
	KG	LBS	MM	INCH	PCS/BOX	✕	
FO059600B	25	55	400X400X460	-	1	12	24
FO059610B	25	55	400X400X460	-	1	12	24



HOSE REELS



ACCESSORIES



MERCHANDISE



AIR



ANTIFREEZE



AdBlue®



BIODIESEL



DIESEL



FOOD



GASOLINE



GREASE



KEROSENE



OIL



WATER



WINDSCREEN

CHART

PANTHER PUMP

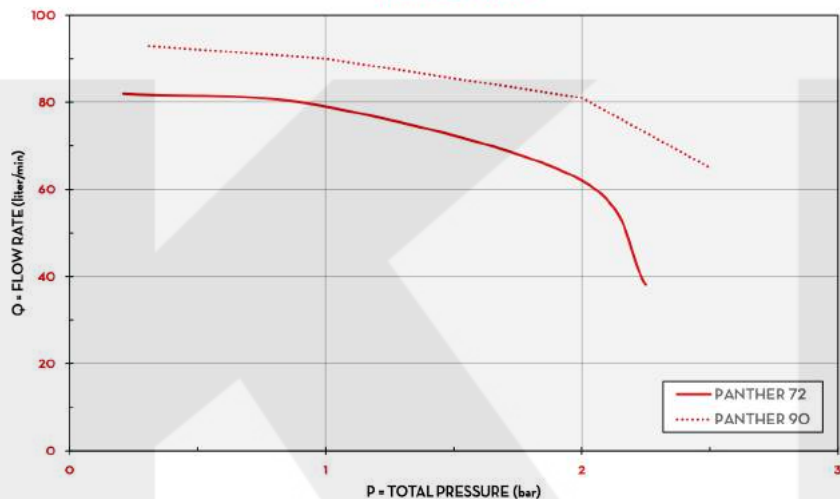

TYPE OF FLUID DIESEL
TEMPERATURE 20-6 °C

IN THE BOX

- CUBE DISPENSER
- AUTOMATIC NOZZLE
- DELIVERY HOSE
- INSTRUCTION MANUAL

DETAILS



SHUTTER



USER&VEHICLE KEY (n.i.)



SSM 2.0 SOFTWARE (pag. 152)



DATA TRANSFER SSM2.0 (pag. 154)

DIMENSIONS

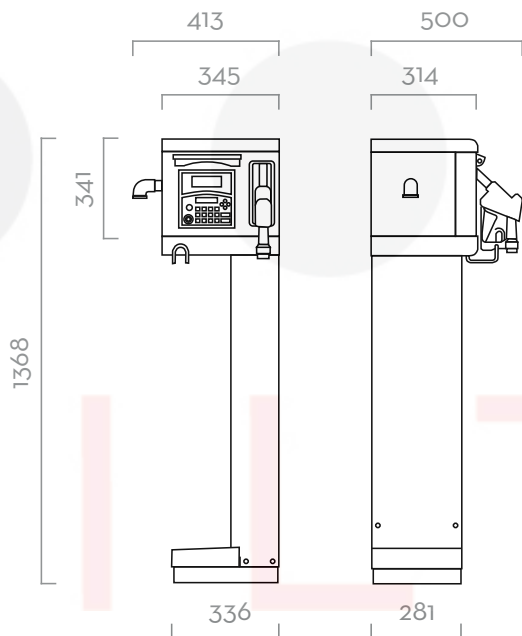

Dimensions expressed in millimeters

COMPONENTS

- **PUMPS:**
 PANTHER AC PAG. 64
 PANTHER DC PAG. 78
- **METER:**
 K600/3 PAG. 96
- **NOZZLE:**
 AUTOMATIC NOZZLE PAG. 118

TECHNICAL DATA

CODE	DESCRIPTION	FLUIDS TYPE	FLOW-RATE		VOLTAGE			PUMP	METER	NOZZLE	FILTER	INLET	SELF SERVICE MANAGEMENT 2.0
			L/MIN	GPM	AC V./HZ DC VOLT	POWER WATT	AMP. MAX.						
FO059600B	CUBE 70 MC 2.0	D	70	18	230/50	900	4,9	PANTH 72	K600	A60	NO	1"	REQUIRED
FO059610B	CUBE 90 MC 2.0	D	90	23,8	230/50	900	4,9	PANTH 90	K600	A120	NO	1"	REQUIRED



DISPENSERS



PUMPS



METERS



NOZZLE



FILTRATION



FLUID MONITORING

DRUM

FEATURES

- EASY TO INSTALL
- SUITABLE FOR ALL DRUMS
- DIFFERENT PUMPS FOR ANY NEED
- AC/DC VERSIONS

The PIUSI DRUM is a compact fuel transfer unit suitable to be connected on drums thanks to the quick 2" coupling. Available with different pumps, the system is (always) equipped with a telescopic suction hose and the nozzle holder located above the drum, near the pump, for easy, clean and safe operations. K33 mechanical meter available on request.

PERFORMANCE

UP TO

80 L/MIN

FLOW-RATE

AC/DC

VOLTAGE

POWER

± 1%

ACCURACY



DRUM PANTHER 56 K33



DRUM BI-PUMP 12V

PACKAGING

CODE		WEIGHT		PACKAGING		
WITHOUT METER	WITH METER	KG	LBS	MM	INCH	PCS/BOX
OO0271POO	OO0272POO	13,5	29,8	480X370X265	18,3X14,6X10,4	1
OO0273POO	OO0274POO	14,4	31,7	480X370X265	18,3X14,6X10,4	1
FO022201A	FO022205A	20,7	45,6	480X370X265	18,3X14,6X10,4	1
FO022202A	FO022206A	20,7	45,6	480X370X265	18,3X14,6X10,4	1
FO022203A	FO022207A	21,6	47,6	480X370X265	18,3X14,6X10,4	1
FO022204A	FO022208A	21,6	47,6	480X370X265	18,3X14,6X10,4	1
-	FO034111C	14,7	31,7	480X370X265	18,3X14,6X10,4	1



HOSE REELS



ACCESSORIES



MERCHANDISE



AIR



ANTIFREEZE



AdBlue®



BIODIESEL



DIESEL



FOOD



GASOLINE



GREASE



KEROSENE



OIL



WATER



WINDSCREEN

CHART

PUMPS

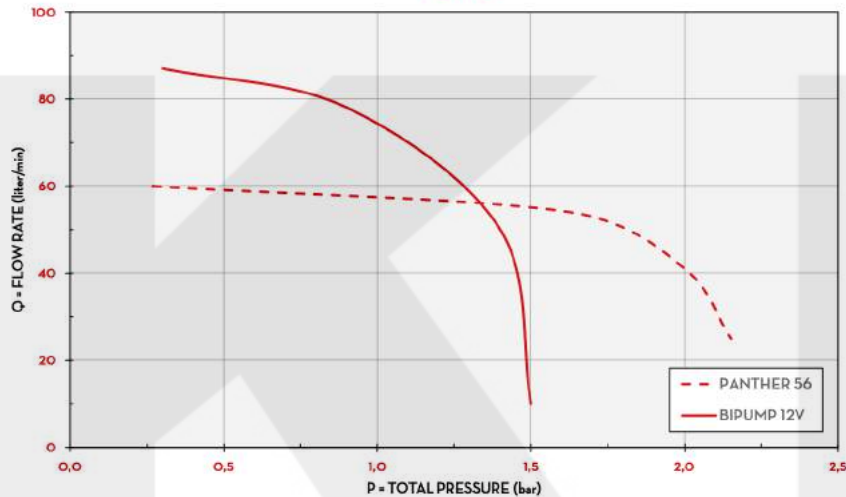

TYPE OF FLUID DIESEL

TEMPERATURE 9-10 °C

IN THE BOX

- PUMP DRUM UNIT
- TELESCOPIC SUCTION PIPE
- DELIVERY HOSE
- NOZZLE
- 2" CONNECTOR
- K33 MECHANICAL METER (ON REQUEST)
- INSTRUCTION MANUAL

DETAILS



2" CONNECTOR



TELESCOPIC SUCTION HOSE

ELECTRIC CABLE WITH CLAMPS
(only dc version)

DIMENSIONS

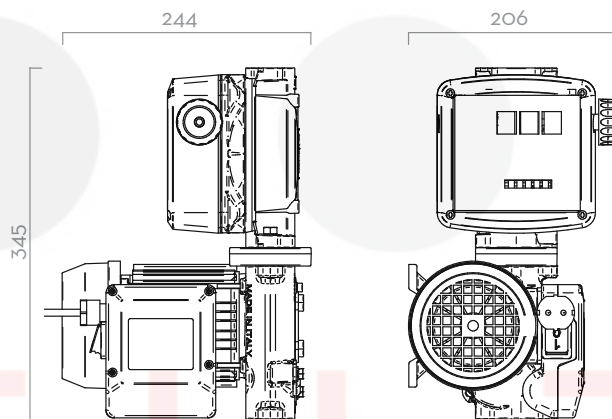

Dimensions expressed in millimeters

COMPONENTS

- DEPENDING ON PUMP MODEL, SEE REFERRED PAGES.

TECHNICAL DATA

CODE		DESCRIPTION	FLUIDS TYPE	FLOW-RATE		VOLTAGE			METER	NOZZLE	INLET	HOSE
WITHOUT METER	WITH METER			L/MIN	GPM	AC V/Hz	DC VOLT	POWER WATT				
000271POO	000272POO	DRUM PANTHER 56	D	56	15	230/50	350	3	K33	MAN.	3/4"	4M
000273POO	000274POO	DRUM PANTHER 56 A60	D	56	15	230/50	350	3	K33	AUT.	3/4"	4M
FO022201A	FO022205A	DRUM BI-PUMP 12V	D	80	21	12V	530	44	K33	MAN.	1"	4M
FO022202A	FO022206A	DRUM BI-PUMP 24V	D	80	21	24V	540	22,5	K33	AUT.	1"	4M
FO022203A	FO022207A	DRUM BI-PUMP 12V A120	D	80	21	12V	530	44	K33	AUT.	1"	4M
FO022204A	FO022208A	DRUM BI-PUMP 24V A120	D	80	21	24V	540	22,5	K33	MAN.	1"	4M
-	FO034111C	DRUM PANTHER DC 24/12V K33 A60	D	56	15	24/12V	150	25/16A	K33	AUT.	3/4"	4M



DISPENSERS



PUMPS



METERS



NOZZLE



FILTRATION



FLUID MONITORING

PICO

FEATURES

- **READY TO USE**
- **TURBINE FLOW-METER (K24 VERSION ONLY)**
- **WEATHER PROOF MATERIALS**
- **STURDY DESIGN**

The PIUSI PICO is a dispensing unit suitable to transfer diesel, antifreeze and windscreen. It includes a centrifugal pump ready to be fit on any kind of drum (vertical installation with built-in connection). K24 meter and automatic nozzle available on request.

PERFORMANCE

UP TO

35 L/MIN

FLOW-RATE

AC/DC

VOLTAGE

POWER

± 1%

ACCURACY



PICO WITHOUT METER

PICO WITH METER

PACKAGING

CODE	WEIGHT		PACKAGING		
	KG	LBS	MM	INCH	PCS/BOX
VERSIONS WITH METER					
FO0202020	4,8	10,6	360X360X180	14,2X14,2X7,1	1
FO0202030	5,8	12,8	360X360X180	14,2X14,2X7,1	1
FO0202060	4,8	10,6	360X360X180	14,2X14,2X7,1	1
FO0202070	5,8	12,8	360X360X180	14,2X14,2X7,1	1
FO0202100	4,8	10,6	360X360X180	14,2X14,2X7,1	1
FO0202110	5,8	12,8	360X360X180	14,2X14,2X7,1	1
VERSIONS WITHOUT METER					
FO0202000	4,8	10,6	360X360X180	14,2X14,2X7,1	1
FO0202010	5,8	12,8	360X360X180	14,2X14,2X7,1	1
FO0202040	4,8	10,6	360X360X180	14,2X14,2X7,1	1
FO0202050	5,8	12,8	360X360X180	14,2X14,2X7,1	1
FO0202080	4,8	10,6	360X360X180	14,2X14,2X7,1	1
FO0202090	5,8	12,8	360X360X180	14,2X14,2X7,1	1



HOSE REELS



ACCESSORIES



MERCHANDISE



AIR



ANTIFREEZE



AdBlue®



BIODIESEL



DIESEL



FOOD



GASOLINE



GREASE



KEROSENE



OIL



WATER



WINDSCREEN

CHART

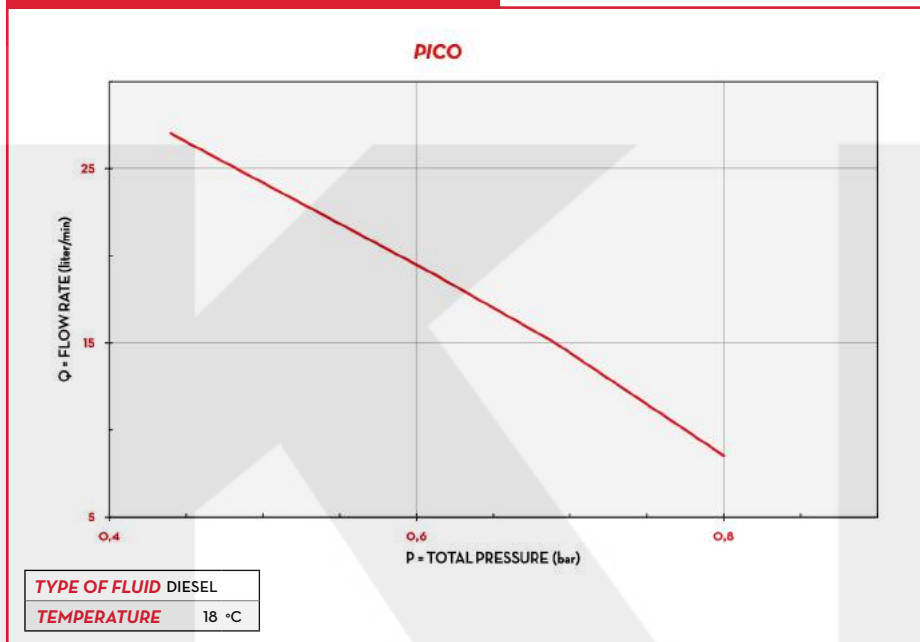

IN THE BOX

- PICO UNIT
- DELIVERY HOSE
- SUCTION PIPE
- MANUAL/AUTOMATIC NOZZLE
- METER (ON REQUEST)
- INSTRUCTION MANUAL

DETAILS

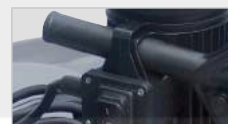

ON/OFF SWITCH



VERSION WITH METER

ELECTRIC CABLE WITH CLAMPS
(only dc version)

DIMENSIONS

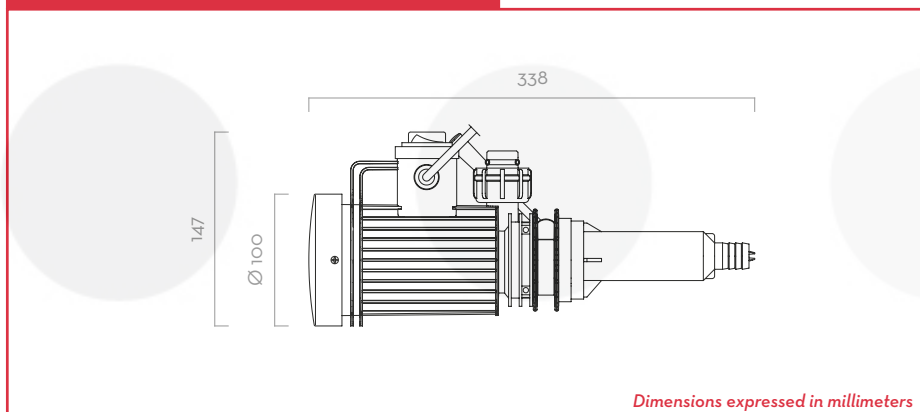

MATERIALS

- BODY: TECHNOPOLYMER
- TURBINES: TECHNOPOLYMER

TECHNICAL DATA

CODE	DESCRIPTION	FLUIDS TYPE	FLOW-RATE		VOLTAGE			PUMP	DUTY CYCLE	NOZZLE	HOSE		FOOT FILTER
			L/MIN	GPM	AC V/HZ	DC VOLT	POWER WATT				AMP. MAX.	TYPE	
VERSIONS WITH METER													
FOO202020	PICO 230 K24 M	A D W	35	9	230/50	224	1	PICO	-	MAN.	4M	3/4"	YES
FOO202030	PICO 230 K24 A	A D W	30	8	230/50	224	1	PICO	-	AUT.	4M	3/4"	YES
FOO202060	PICO 12 K24 M	A D W	30	8	12	110	9	PICO	30	MAN.	4M	3/4"	YES
FOO202070	PICO 12 K24 A	A D W	25	7	12	110	9	PICO	30	AUT.	4M	3/4"	YES
FOO202100	PICO 24 K24 M	A D W	30	8	24	135	5,5	PICO	30	MAN.	4M	3/4"	YES
FOO202110	PICO 24 K24 A	A D W	25	7	24	135	5,5	PICO	30	AUT.	4M	3/4"	YES
VERSIONS WITHOUT METER													
FOO202000	PICO 230 M	A D W	35	9	230/50	224	1	PICO	-	MAN.	4M	3/4"	YES
FOO202010	PICO 230 A	A D W	30	8	230/50	224	1	PICO	-	AUT.	4M	3/4"	YES
FOO202040	PICO 12 M	A D W	30	8	12	110	9	PICO	30	MAN.	4M	3/4"	YES
FOO202050	PICO 12 A	A D W	25	7	12	110	9	PICO	30	AUT.	4M	3/4"	YES
FOO202080	PICO 24 M	A D W	30	8	24	135	5,5	PICO	30	MAN.	4M	3/4"	YES
FOO202090	PICO 24 A	A D W	25	7	24	135	5,5	PICO	30	AUT.	4M	3/4"	YES



DISPENSERS



PUMPS



METERS



NOZZLE



FILTRATION



FLUID MONITORING

BATTERY KIT

FEATURES

- VERSATILITY
- MOBILE AND READY TO USE
- ON/OFF SWITCH

The PIUSI BATTERY KIT is a portable transfer unit with a self-priming electric vane pump. Its modular composition allows users to have different pumps according to the required flow-rates and different applications. It is equipped with a fixed brush motor with permanent magnet stator and terminal board with switches and fuses to protect against overload. It is always supplied with integrated nozzle and a set of accessories.

PERFORMANCE

UP TO
80 L/MIN

FLOW-RATE

12/24V

VOLTAGE
POWER

30 MIN

DUTY CICLE

UP TO
2MT

SELF-PRIMING



BATTERY KIT 3000



PACKAGING

CODE	WEIGHT		PACKAGING			N. BOXES / EUROPALLET	
	KG	LBS	MM	INCH	PCS/BOX	✈	🚚
BATTERY KIT 3000							
FO022500C	7,8	17,3	300X300X180	-	1	50	100
FO022600C	7,8	17,3	300X300X180	-	1	50	100
FO0225410	7,8	17,3	300X300X180	-	1	50	100
FO0226380	7,8	17,3	300X300X180	-	1	50	100
BATTERY KIT 3000							
FO034003B	7,8	17,3	300X300X180	-	1	24	36
FO034103C	7,8	17,3	300X300X180	-	1	24	36
FO034006B	12,5	27,6	330057X357X275	-	1	24	36
FO0341220	13	28,7	357X357X275	-	1	24	36
FO034106C	12,5	27,6	357X357X275	-	1	24	36
BATTERY KIT BIPUMP							
FO0363280	18	39,7	480X370X265	-	1		
BATTERY KIT OIL							
FO0309060	7,8	17,3	300X300X180	-	1	50	100
FO0310070	7,8	17,3	300X300X180	-	1	50	100



HOSE REELS



ACCESSORIES



MERCHANDISE



AIR



ANTIFREEZE



AdBlue®



BIODIESEL



DIESEL



FOOD



GASOLINE



GREASE



KEROSENE



OIL



WATER



WINDSCREEN

**BATTERY KIT BI-PUMP****BATTERY KIT 3000 INLINE****BATTERY KIT OIL****BATTERY KIT PANTHER****IN THE BOX**

- PUMP
- SUCTION HOSE
- DELIVERY HOSE
- HANDLE
- NOZZLE
- MESH FILTER AND CONNECTIONS
- CABLES
- INSTRUCTION MANUAL

DETAILS

HANDLE



ON/OFF SWITCH



ELECTRIC CABLE

MATERIALS

- DEPENDING ON PUMP MODEL. SEE REFERRED PAGES

TECHNICAL DATA

CODE	DESCRIPTION	FLUIDS TYPE	FLOW-RATE		VOLTAGE			FUSES CAPACITY	PUMP TYPE	DUTY CYCLE MINUTES	NOZZLE TYPE	HOSE		CHECK FILTER	
			L/MIN	GPM	AC V/ HZ	DC VOLT	POWER WATT					AMP. MAX.	LENGTH		Ø
BATTERY KIT 3000															
FO022500C	BATTERY KIT 3000 12V	D	50	13	12	220	22	25	CARRY 3000	PAG.	30	MAN.	4M	3/4"	YES
FO022600C	BATTERY KIT 3000 24V	D	50	13	24	310	13	15	CARRY 3000	PAG.	30	MAN.	4M	3/4"	YES
FO0225410	BATTERY KIT 3000 INLINE 12V	D	50	13	12	220	22	25	CARRY 3000	PAG.	30	MAN.	4M	3/4"	YES
FO0226380	BATTERY KIT 3000 INLINE 24V	D	50	13	24	310	13	15	CARRY 3000	PAG.	30	MAN.	4M	3/4"	YES
BATTERY KIT PANTHER															
FO034003B	BATTERY KIT PANTHER 12V	D	56	15	12	300	35	40	PANTHER DC	PAG.	30	MAN.	4M	3/4"	YES
FO034103C	BATTERY KIT PANTHER 12-24V	D	35/70	9/18	24/12	420/150	25/16	30/30	PANTHER DC	PAG.	30	MAN.	4M	3/4"	YES
FO034006B	BATTERY KIT PANTHER 12V	D	56	15	12	420	35	-	PANTHER DC	PAG.	30	MAN.	5M	3/4"	YES
FO0341220	BATTERY KIT PANTHER 12-24V	D	35/70	9/18	12/24	600/200	25/16	-	PANTHER DC	PAG.	30	AUT.	5M	3/4"	YES
FO034106C	BATTERY KIT PANTHER 12-24V	D	35/70	9/18	12/24	600/200	25/16	-	PANTHER DC	PAG.	30	MAN.	5M	3/4"	YES
BATTERY KIT BIPUMP															
FO0363280	BATTERY KIT BIPUMP 12V	D	80	21	12	300	22	-	BIPUMP DC	PAG.	30	AUT.	6M	3/4"	YES
BATTERY KIT OIL															
FO0309060	BATTERY KIT VISCOMAT 12V	O	10	3	12	300	22	-	VISCOMAT DC	PAG.	30	MAN.	4M	3/4"	YES
FO0310070	BATTERY KIT VISCOMAT 24V	O	10	3	24	300	18	-	VISCOMAT DC	PAG. 50	30	MAN.	4M	3/4"	YES

BATTERY KIT



DISPENSERS



PUMPS



METERS



NOZZLE



FILTRATION



FLUID MONITORING

PITSTOP

FEATURES

- **READY TO INSTALL**
- **VERSATILITY**
- **STURDY STRUCTURE**

The PIUSI PITSTOP is a dispenser unit with two DC pumps, automatic hose reel, water filter and automatic nozzle with 14 meter. hose integrated into a sturdy supporting structure. Easy to install, versatile and compact, this dispenser is the all-in-one solution for setting up a perfect mobile refueling unit.

PERFORMANCE

UP TO

45 L/MIN

FLOW-RATE

12/24V

VOLTAGE

POWER

14MT

HOSE LENGTH

HOSE REEL

200β/30μ

FILTRING CAPACITY



PITSTOP DC



PACKAGING

CODE	WEIGHT		PACKAGING		
	KG	LBS	MM	INCH	PCS/BOX
FO0212000	45	99	595X465X670	23,4X13,5X24,4	1
FO0213000	45	99	595X465X670	23,4X13,5X24,4	1



HOSE REELS



ACCESSORIES



MERCHANDISE



AIR



ANTIFREEZE



AdBlue®



BIODIESEL



DIESEL



FOOD



GASOLINE



GREASE



KEROSENE



OIL



WATER



WINDSCREEN

CHART

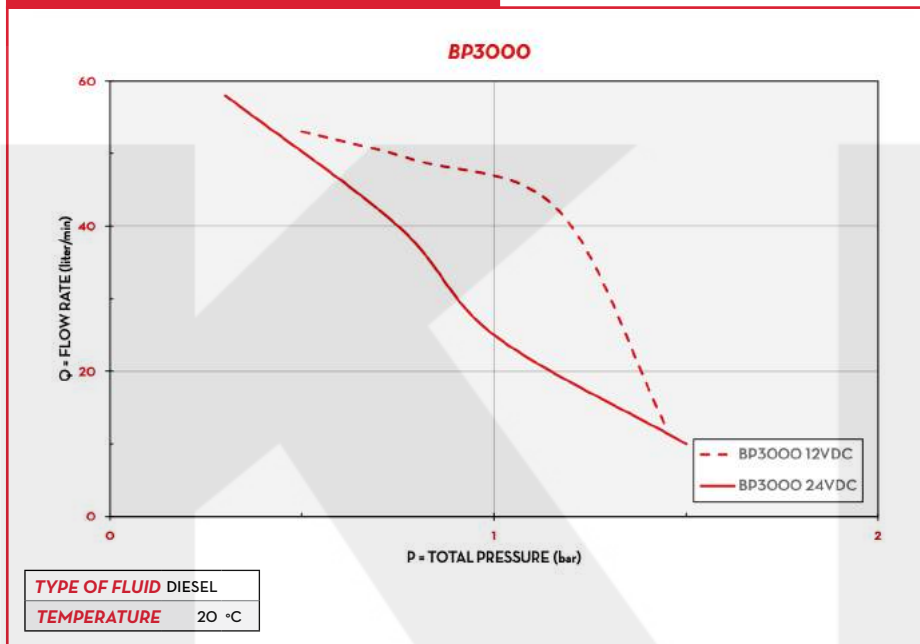

IN THE BOX

- PITSTOP UNIT
- AUTOMATIC NOZZLE
- FILTER
- INSTRUCTION MANUAL

DETAILS



BUILT-IN DC PUMPS

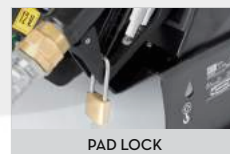

PAD LOCK



ON/OFF SWITCH



ADJUSTABLE ARM

DIMENSIONS

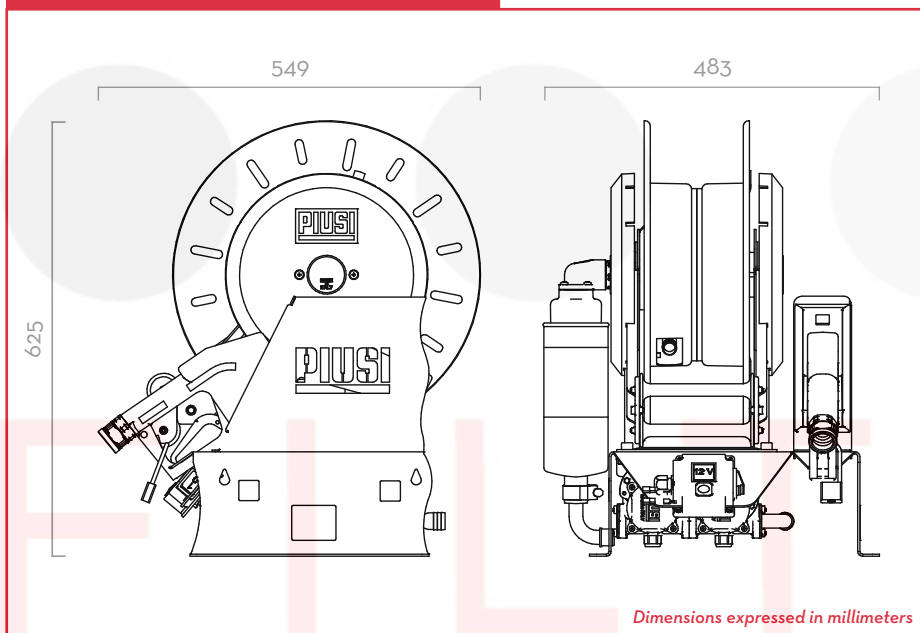

COMPONENTS

- PUMP: BP3000 PAG. 74
- FILTER: WATER CAPTOR PAG. 128
- NOZZLE: A60 PAG. 118

TECHNICAL DATA

CODE	DESCRIPTION	FLUIDS TYPE	FLOW-RATE		VOLTAGE			PUMP		DUTY CYCLE	NOZZLE	HOSE		INLET
			L/MIN	GPM	AC V./HZ DC VOLT	POWER WATT	AMP. MAX.	TYPE	N°			LENGTH	Ø	
FO0212000	PIUSI PITSTOP DC 12V	D	45	11,9	12	400	33	BP 3000	2	30	AUT.	14M	3/4"	1"
FO0213000	PIUSI PITSTOP DC 24V	D	45	11,9	24	620	26	BP 3000	2	30	AUT.	14M	3/4"	1"



DISPENSERS



PUMPS



METERS



NOZZLE



FILTRATION



FLUID
MONITORING

PIUSIBOX

FEATURES

- SELF PRIMING PUMP
- BUILT-IN FILTER (PRO VERSION)
- EASY TO REPACK
- IP55

The PIUSIBOX is a portable fuel dispenser integrated with a self-priming transfer pump, filter, check valve and manual nozzle. Suitable for quick and safe refuel operations in all the situations where an easy mobile refueling solution is required.

PERFORMANCE

UP TO

45 L/MIN

FLOW-RATE

12/24V

VOLTAGE

POWER

30 MIN

DUTY CYCLE



PIUSIBOX



PACKAGING

CODE	WEIGHT		PACKAGING			N. BOXES / EUROPALLET	
	KG	LBS	MM	INCH	PCS/BOX	✕	
FO023100B	9,5	20,9	400X300X420	-	1	24	32
FO023101B	12	26,5	400X300X420	-	1	24	32
FO023200B	9,5	20,9	400X300X420	-	1	24	32
FO023201B	12	26,5	400X300X420	-	1	24	32



HOSE REELS



ACCESSORIES



MERCHANDISE



AIR



ANTIFREEZE



AdBlue®



BIODIESEL



DIESEL



FOOD



GASOLINE



GREASE



KEROSENE



OIL



WATER



WINDSCREEN

CHART

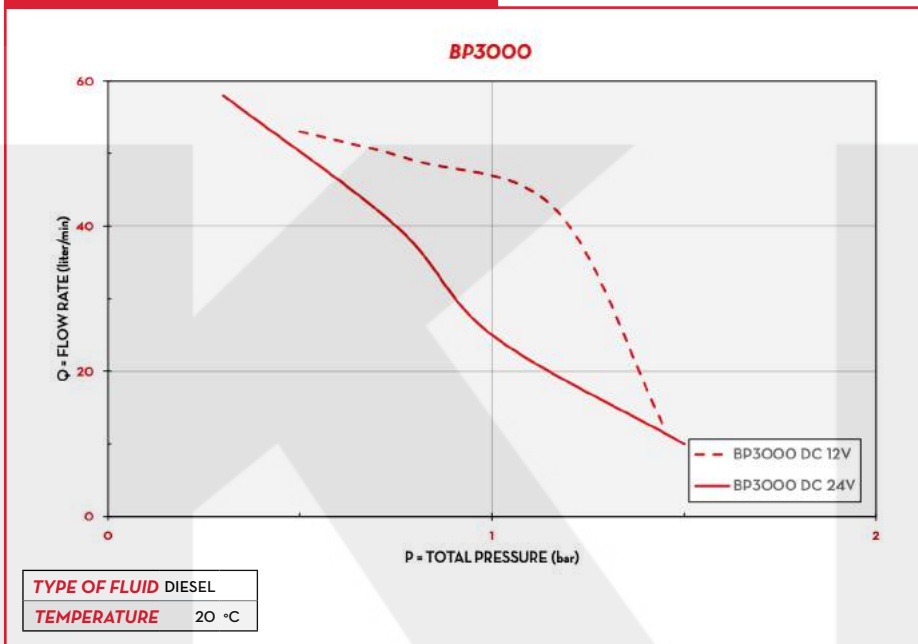

IN THE BOX

- PIUSIBOX UNIT
- SUCTION&DELIVERY HOSE
- OIL&FUEL FILTER (PRO VERSION)
- CHECK VALVE
- INSTRUCTION MANUAL

DETAILS

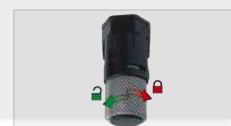

CHECK VALVE



OIL&FUEL FILTER (pag.132)



ROTATING CONNECTION



ERGONOMIC HANDLE

DIMENSIONS

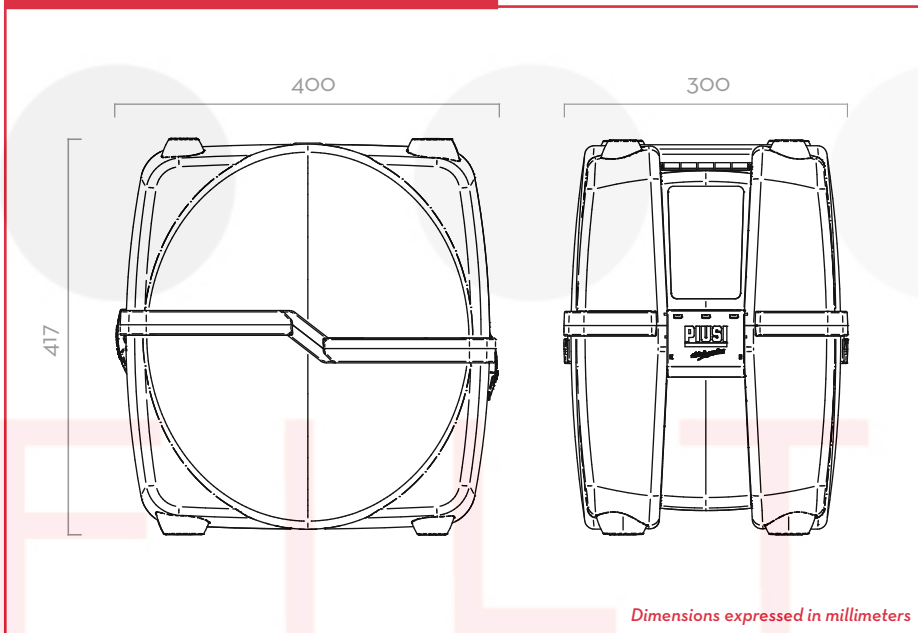

MATERIALS

- BODY: CAST IRON
- ROTOR: SINTERED STEEL
- VANES: ACETAL RESIN
- SEAL: NBR
- SHAFT: STEEL

TECHNICAL DATA

CODE	DESCRIPTION	FLUIDS TYPE	FLOW-RATE		VOLTAGE			PUMP TYPE	DUTY CYCLE MINUTES	FILTER	CARTRIDGE	NOZZLE TYPE	DELIVERY HOSE 5/8"	SUCTION HOSE 3/4"	FOOT VALVE MOD. VANTAGE
			L/MIN	GPM	AC V./HZ DC VOLT	POWER WATT	AMP. MAX.								
FOO23100B	PIUSIBOX 12V BASIC	D	45	11,9	12	400	33	BP 3000	30	NO	NO	MAN.	4M	2M	YES
FOO23101B	PIUSIBOX 12V PRO	D	43	11,7	24	620	26	BP 3000	30	YES	10μ	MAN.	4M	2M	YES
FOO23200B	PIUSIBOX 24V BASIC	D	45	11,9	12	400	33	BP 3000	30	NO	NO	MAN.	4M	2M	YES
FOO23201B	PIUSIBOX 24V PRO	D	43	11,7	24	620	26	BP 3000	30	YES	10μ	MAN.	4M	2M	YES



DISPENSERS



PUMPS



METERS



NOZZLE



FILTRATION



FLUID MONITORING

SELF SERVICE K44

FEATURES

- ALL-IN-ONE EQUIPMENT
- WATER CAPTOR FILTER
- COMPACT DESIGN
- IP55

The PIUSI SELF SERVICE K44 is a fuel dispenser unit equipped with a high capacity vane pump, built-in bypass valve and mechanical K44 meter particularly suitable for all the needs of high-flow rate diesel dispensing while guaranteeing that the dispensed product is free of water and impurities thanks to the integrated filter (column version). Available both as column or tank version, it features a front door for easy maintenance.

PERFORMANCE

UP TO

90 L/MIN

FLOW-RATE

AC

CONTINUOUS DUTY

POWER

± 1%

ACCURACY



MECHANICAL METER INTEGRATED



SELF SERVICE K44

PACKAGING

CODE	WEIGHT		PACKAGING			N. BOXES / EUROPALET	
	KG	LBS	MM	INCH	PCS/BOX	✕	
COLUMN VERSIONS							
FO073701B	67	148	1478X488X400	-	1	6*	4
FO074001B	75	165	1478X488X400	-	1	6*	4
FO074002A	75	165	1478X488X400	-	1	6*	4
TANK VERSIONS							
FO0737B0B	57	126	1080X488X400	-	1	6*	4
FO0740B0B	65	143	1080X488X400	-	1	6*	4
FO0737B2B	57	126	1080X488X400	-	1	6*	4



HOSE REELS



ACCESSORIES



MERCHANDISE



AIR



ANTIFREEZE



AdBlue®



BIODIESEL



DIESEL



FOOD



GASOLINE



GREASE



KEROSENE



OIL



WATER



WINDSCREEN

CHART

PANTHER 72 / E120

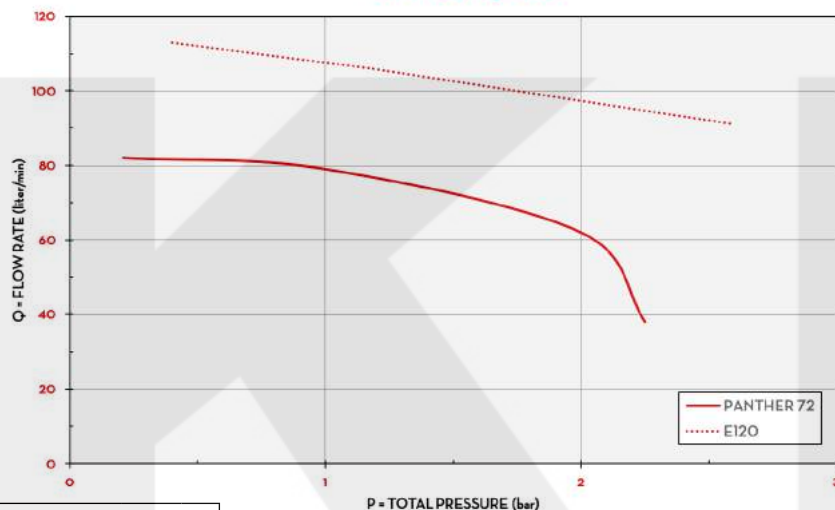

TYPE OF FLUID DIESEL

TEMPERATURE 20-13 °C

P = TOTAL PRESSURE (bar)

IN THE BOX

- K44 UNIT
- DELIVERY HOSE
- AUTOMATIC NOZZLE
- INSTRUCTION MANUAL

DETAILS



K44 (pag. 108)



INTEGRATED FILTER (pag. 128)

DIMENSIONS

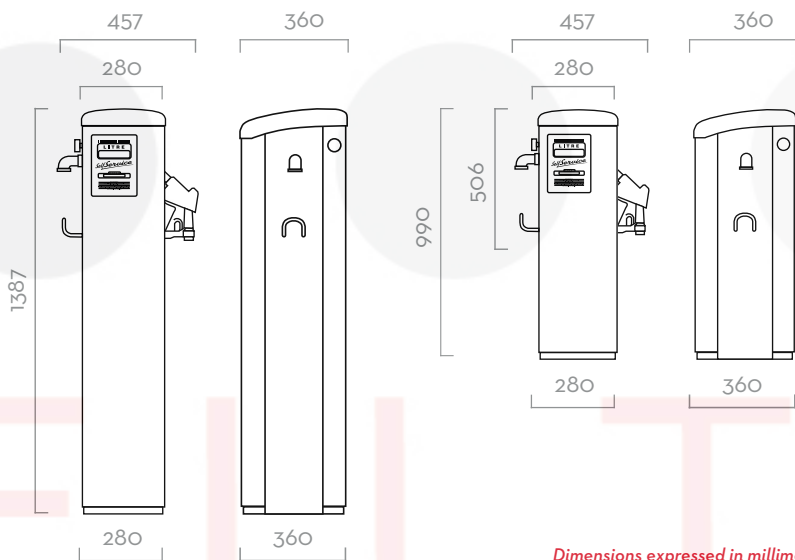

Dimensions expressed in millimeters

COMPONENTS

- **PUMPS:**
PANTHER 72 / E120 PAG. 64/68
- **METER:**
K600/3 PAG. 96
- **NOZZLE:**
AUTOMATIC NOZZLE PAG. 118
- **FILTER:**
WATER CAPTOR PAG. 128

TECHNICAL DATA

CODE	DESCRIPTION	FLUIDS TYPE	FLOW-RATE		VOLTAGE			PUMP	METER	NOZZLE	FILTER		INLET	PC
			L/MIN	GPM	AC V./HZ	DC VOLT	POWER WATT				AMP. MAX.	H2O FILTER		
COLUMN VERSIONS														
FO073701B	SELF SERVICE 70 K44	D	70	18	230/50	550	3,3	PANTH 72	K44	AUT.	YES	30μ	1" 1/2	NO
FO074001B	SELF SERVICE 100 K44	D	90	24	230/50	1150	5,7	E 120	K44	AUT.	YES	30μ	1" 1/2	NO
FO074002A	SELF SERVICE 100 K44 PULSER	D	90	24	230/50	1150	5,7	E 120	K44 P	AUT.	YES	30μ	1" 1/2	NO
TANK VERSIONS														
FO0737BOB	SELF SERVICE 70 K44 TANK	D	70	18	230/50	550	3,3	PANTH 72	K44	AUT.	NO	-	1" 1/2	NO
FO0740BOB	SELF SERVICE 100 K44 TANK	D	90	24	230/50	1150	5,7	E 120	K44	AUT.	NO	-	1" 1/2	NO
FO0737B2B	SELF SERVICE 70 K44 TANK PULSER	D	70	18	230/50	550	3,3	PANTH 72	K44 P	AUT.	NO	-	1" 1/2	NO

UPON REQUEST IT IS AVAILABLE WITH DIFFERENT VOLTAGES AND 60 HZ FREQUENCY

SELF SERVICE K44



DISPENSERS



PUMPS



METERS



NOZZLE



FILTRATION



FLUID
MONITORING

SELF SERVICE MC

FEATURES

- MULTI-USER MANAGEMENT
- WATER CAPTOR FILTER
- ALL-IN-ONE EQUIPMENT
- COMPACT DESIGN
- COMPATIBLE WITH SSM 2018 SOFTWARE
- IP55

The PIUSI SELF SERVICE MC is a complete device suitable to fit all diesel-dispensing needs. With its sturdy structure, this dispenser is equipped with a high capacity vane pump, built-in bypass, automatic nozzle, water captor filter and electronic panel able to manage up to 80 users and 255 transactions.

PERFORMANCE

UP TO
90 L/MIN

FLOW-RATE

AC
CONTINUOUS DUTY

POWER

± 0,5%

ACCURACY

UP TO
80

USERS



ELECTRONIC METER INTEGRATED



SELF SERVICE MC

PACKAGING

CODE	WEIGHT		PACKAGING			N. BOXES / EUROPALET	
	KG	LBS	MM	INCH	PCS/BOX	✕	
COLUMN VERSIONS							
FO073801D	67	148	1478X488X400	-	1	6*	4
FO074101D	75	165	1478X488X400	-	1	6*	4
FO073806A	75	148	1478X488X400	-	1	6*	4
TANK VERSIONS							
FO0738B0D	57	126	1080X488X400	-	1	6*	4
FO0741B0D	65	143	1080X488X400	-	1	6*	4



HOSE REELS



ACCESSORIES



MERCHANDISE



AIR



ANTIFREEZE



AdBlue®



BIODIESEL



DIESEL



FOOD



GASOLINE



GREASE



KEROSENE



OIL



WATER



WINDSCREEN

CHART

E120 / PANTHER 72

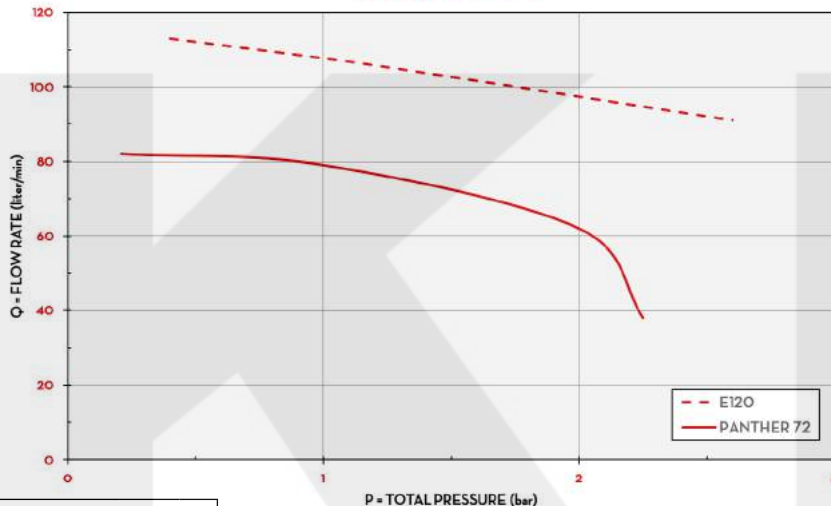

TYPE OF FLUID DIESEL

TEMPERATURE 13-20 °C

P - TOTAL PRESSURE (bar)

IN THE BOX

- SELF SERVICE MC UNIT
- DELIVERY HOSE
- AUTOMATIC NOZZLE
- INSTRUCTION MANUAL

DETAILS



TANK VERSION AVAILABLE



WATER CAPTOR FILTER (pag. 128)



DRIVER KEY (not included)



SSM 2018 (pag. 148)

COMPONENTS

- **PUMPS:**
PANTHER 72 / E120 PAG. 64/68
- **METER:**
K600/3 PAG. 96
- **NOZZLE:**
AUTOMATIC NOZZLE PAG. 118
- **FILTER:**
WATER CAPTOR PAG. 128

DIMENSIONS

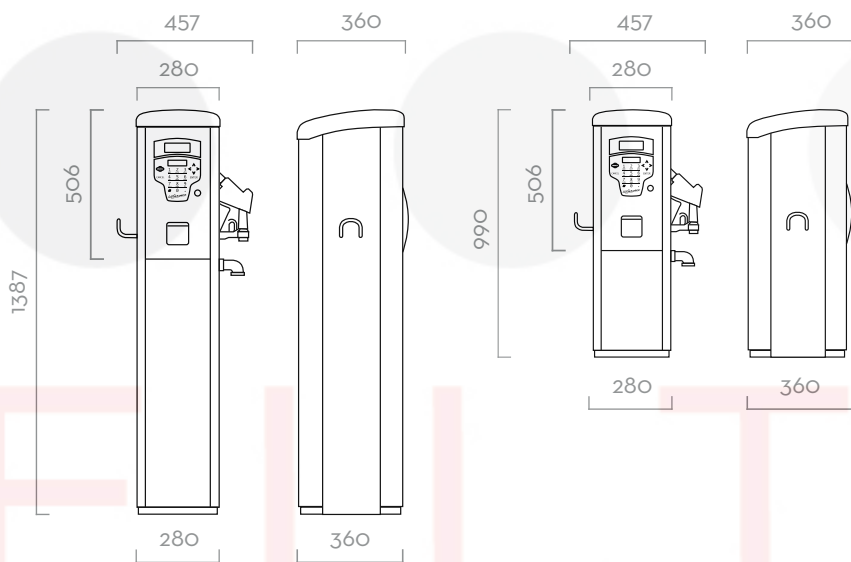

Dimensions expressed in millimeters

TECHNICAL DATA

CODE	DESCRIPTION	FLUIDS TYPE	FLOW-RATE		VOLTAGE			PUMP	METER	NOZZLE	FILTER		INLET	PC
			L/MIN	GPM	AC V./HZ	DC VOLT	POWER WATT				AMP. MAX.	H2O FILTER		
COLUMN VERSIONS														
FO073801D	SELF SERVICE 70 MC F	D	70	18	230/50	900	4,2	PANTH 72	K600	AUT.	YES	30µ	1" 1/2	YES
FO074101D	SELF SERVICE 100 MC F	D	90	24	230/50	1150	5,7	E 120	K600	AUT.	YES	30µ	1" 1/2	YES
FO073806A	SELF SERVICE 70 MC F PRINTER*	D	70	18	230/50	900	4,2	PANTH 72	K600	AUT.	YES	30µ	1" 1/2	YES
TANK VERSIONS														
FO0738B0D	SELF SERVICE 70 MC TANK	D	70	18	230/50	900	3,3	PANTH 72	K600	AUT.	NO	-	1" 1/2	YES
FO0741B0D	SELF SERVICE 100 MC TANK	D	90	24	230/50	1150	5,7	E 120	K600	AUT.	NO	-	1" 1/2	YES

*WITH 7M HOSE. UPON REQUEST IT IS AVAILABLE WITH DIFFERENT VOLTAGES AND 60 HZ FREQUENCY



DISPENSERS



PUMPS



METERS



NOZZLE



FILTRATION



FLUID MONITORING

SELF SERVICE MC 2.0

FEATURES

- **STURDY STRUCTURE**
- **ALL-IN-ONE DISPENSER**
- **BUILT-IN LAN ADAPTER**
- **FRONT DOOR FOR EASY MAINTENANCE**
- **SSM 2.0 SOFTWARE REQUIRED**
- **IP55**
- **IDEAL FOR FUEL MANAGEMENT**

The PIUSI SELF SERVICE MC 2.0 is a non-commercial fuel diesel dispenser able to fit any fleet management requirement. It requires the SSM 2.0 software to work. Equipped with 90 l/min continuous duty pump, it is suitable for any fleet dimension.

PERFORMANCE

UP TO

90 L/MIN

FLOW-RATE

AC

CONTINUOUS DUTY

POWER

± 0,5%

ACCURACY

UP TO

1000

USERS



ELECTRONIC METER INTEGRATED



SELF SERVICE MC 2.0

PACKAGING

CODE	WEIGHT		PACKAGING			N. BOXES / EUROPALLET	
	KG	LBS	MM	INCH	PCS/BOX	✕	
COLUMN VERSION							
FO074302B	75	165	1478X488X400	-	1	6*	4



HOSE REELS



ACCESSORIES



MERCHANDISE



AIR



ANTIFREEZE



AdBlue®



BIODIESEL



DIESEL



FOOD



GASOLINE



GREASE



KEROSENE



OIL



WATER



WINDSCREEN

CHART



IN THE BOX

- SELF SERVICE MC 2.0 UNIT
- DELIVERY HOSE
- AUTOMATIC NOZZLE
- INSTRUCTION MANUAL

- PUMP: E80/E120 PAG. 68
- METER: K600/3 PAG. 96
- NOZZLE: AUTOMATIC NOZZLE PAG. 118
- FILTER: WATER CAPTOR PAG. 128

DETAILS



WATER CAPTOR FILTER (pag. 128)



DRIVER&VEHICLE KEY (n.i.)



SSM 2.0 SOFTWARE (pag. 152)



DATA TRANSFER SSM2.0 (pag. 154)

DIMENSIONS

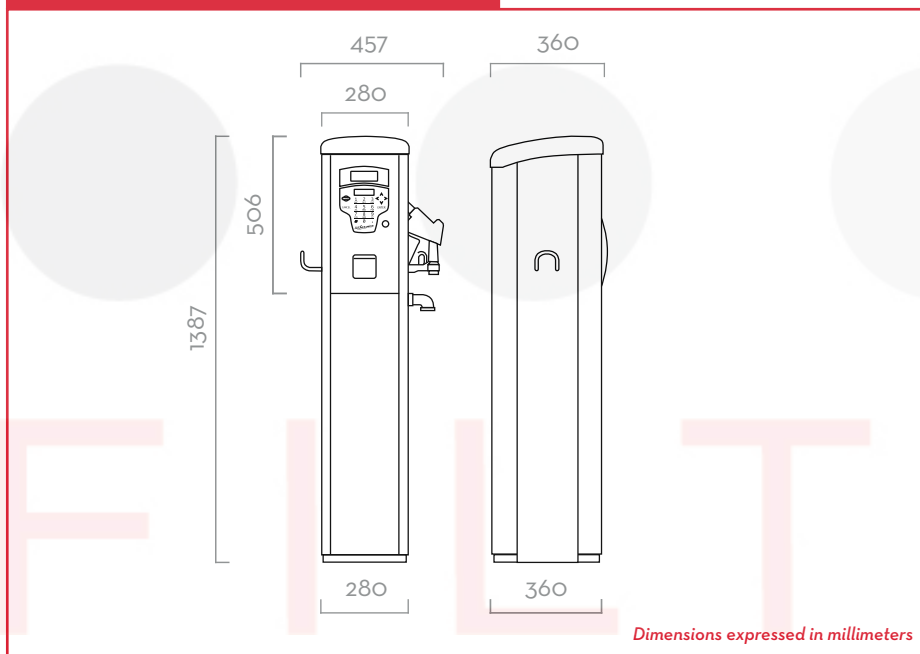

MATERIALS

- **PUMPS:**
E80 / E120 PAG. 68
- **METER:**
K600/3 PAG. 96
- **NOZZLE:**
AUTOMATIC NOZZLE PAG. 118
- **FILTER:**
WATER CAPTOR PAG. 128

TECHNICAL DATA

CODE	DESCRIPTION	FLUIDS TYPE	FLOW-RATE		VOLTAGE			PUMP TYPE	METER TYPE	NOZZLE TYPE	FILTER		INLET BSP	SELF SERVICE MANAGEMENT 2.0
			L/MIN	GPM	AC V/HZ DC VOLT	POWER WATT	AMP. MAX.				H2O FILTER	FILTERING CAPACITY		
COLUMN VERSION														
FO074302B	SELF SERVICE 100 MC 2.0	D	90	24	230/50	1150	5,7	E120	K600	AUT.	YES	30µ	1" 1/2	REQUIRED



DISPENSERS



PUMPS



METERS



NOZZLE



FILTRATION



FLUID
MONITORING

SELF SERVICE FM

FEATURES

- TICKET PRINTER
- MULTI-USER MANAGEMENT
- WATER CAPTOR FILTER
- TANK LEVEL INDICATOR
- STURDY STRUCTURE
- COMPATIBLE WITH SSM 2018 SOFTWARE
- IP55

The PIUSI SELF SERVICE FM is a dispenser for diesel with integrated OCIO tank level indicator. It is equipped with a high-capacity vane pump, built-in bypass, automatic nozzle, water captor filter and electronic panel able to manage up to 120 users and 255 transactions. It is compatible with SSM2018 software.

PERFORMANCE

UP TO

90 L/MIN

FLOW-RATE

AC

CONTINUOUS DUTY

POWER

± 0,5%

ACCURACY

UP TO

120

USERS



INTEGRATED TICKET PRINTER



SELF SERVICE FM

PACKAGING

CODE	WEIGHT		PACKAGING			N. BOXES / EUROPALLET	
	KG	LBS	MM	INCH	PCS/BOX	✈	🚛
FO07390OC	67	148	1478X488X400	-	1	6*	4
FO07420OC	75	165	1478X488X400	-	1	6*	4
FO0739BOC	57	126	1080X488X400	-	1	6*	4
FO0742BOC	65	143	1080X488X400	-	1	6*	4



HOSE REELS



ACCESSORIES



MERCHANDISE



AIR



ANTIFREEZE



AdBlue®



BIODIESEL



DIESEL



FOOD



GASOLINE



GREASE



KEROSENE



OIL



WATER



WINDSCREEN

CHART

E120 / PANTHER 72

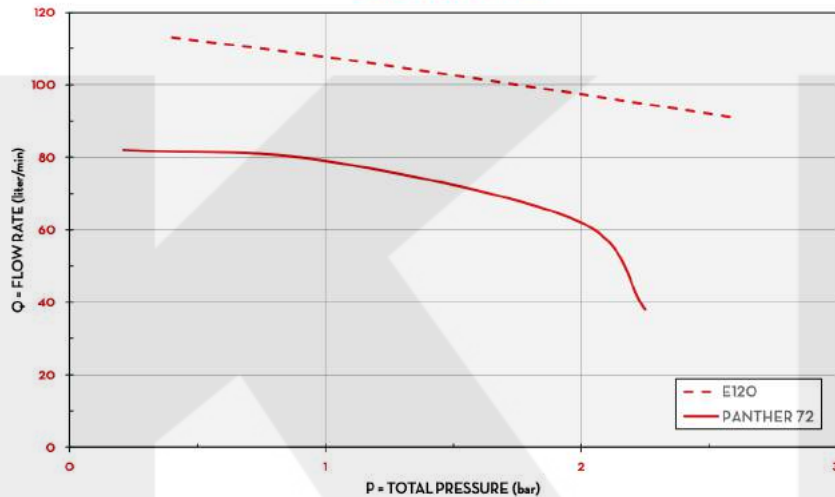

TYPE OF FLUID DIESEL

TEMPERATURE 13-20 °C

IN THE BOX

- SELF SERVICE FM UNIT
- DELIVERY HOSE
- AUTOMATIC NOZZLE
- INSTRUCTION MANUAL

DETAILS



TANK VERSION AVAILABLE



WATER CAPTOR FILTER (pag. 128)



DRIVER KEY (not included)



SSM 2018 (pag. 148)

MATERIALS

- **PUMPS:**
E80 / E120 PAG. 68
- **METER:**
K600/3 PAG. 96
- **NOZZLE:**
AUTOMATIC NOZZLE PAG. 118
- **FILTER:**
WATER CAPTOR PAG. 128

DIMENSIONS

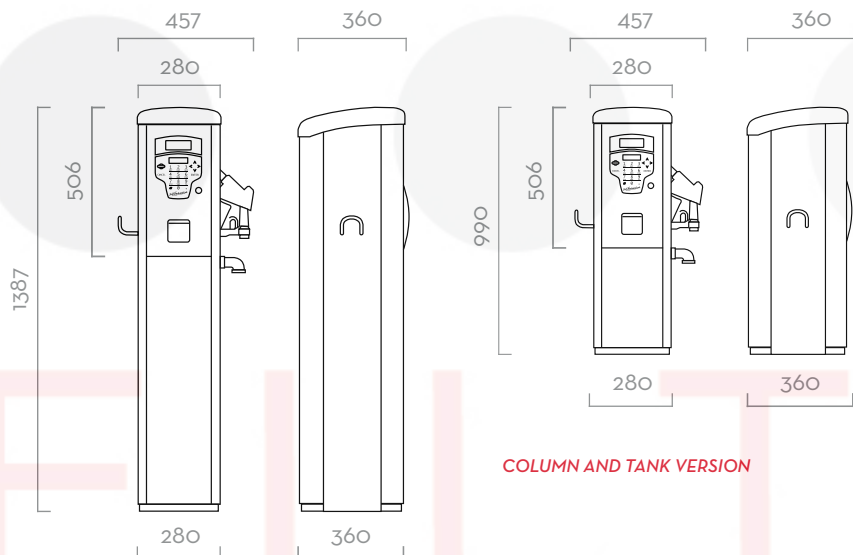

COLUMN AND TANK VERSION

Dimensions expressed in millimeters

TECHNICAL DATA

CODE	DESCRIPTION	FLUIDS TYPE	FLOW-RATE		VOLTAGE			PUMP	METER	NOZZLE	FILTER		INLET	PC
			L/MIN	GPM	AC V./HZ	DC VOLT	POWER WATT				AMP. MAX.	H2O FILTER		
FO073900C	SELF SERVICE 70 FM	D	70	18	230/50	550	3,3	PANTH 72	K600	AUT.	YES	30µ	1" 1/2	YES
FO074200C	SELF SERVICE 100 FM	D	90	24	230/50	1150	5,7	E 120	K600	AUT.	YES	30µ	1" 1/2	YES
FO0739B0C	SELF SERVICE 70 FM TANK	D	70	18	230/50	550	3,3	PANTH 72	K600	AUT.	NO	-	1" 1/2	YES
FO0742B0C	SELF SERVICE 100 FM TANK	D	90	24	230/50	1150	5,7	E 120	K600	AUT.	NO	-	1" 1/2	YES

UPON REQUEST IT IS AVAILABLE WITH DIFFERENT VOLTAGES AND 60 HZ FREQUENCY



DISPENSERS



PUMPS



METERS



NOZZLE



FILTRATION



FLUID
MONITORING

SELF SERVICE FM 2.0

FEATURES

- IDEAL FOR FUEL MANAGEMENT
- TANK LEVEL INDICATOR
- TICKET PRINTER
- MULTI-USER MANAGEMENT
- STURDY STRUCTURE
- EASY MAINTENANCE
- HIGH DISPLACEMENT VANE PUMP
- SSM 2.0 SOFTWARE REQUIRED
- IP55

The PIUSI SELF SERVICE FM 2.0 is the top-level, all-in-one dispenser for fuel with integrated LAN connection to guarantee continuous communication between dispenser and PC, water captor filter to ensure the highest purity of fluids, OCIO 2.0 tank level indicator and an electronic panel able to manage up to 1000 users and 650 transactions. Compatible with SSM 2.0 software.

PERFORMANCE

UP TO

90 L/MIN

FLOW-RATE

AC

CONTINUOUS DUTY

POWER

± 0,5%

ACCURACY

UP TO

1000

USERS



INTEGRATED TICKET PRINTER



SELF SERVICE FM 2.0

PACKAGING

CODE	WEIGHT		PACKAGING			N. BOXES / EUROPALLET	
	KG	LBS	MM	INCH	PCS/BOX	✕	
COLUMN VERSION							
FO074301A	75	165	1478X488X400	-	1	6*	4



HOSE REELS



ACCESSORIES



MERCHANDISE



AIR



ANTIFREEZE



AdBlue®



BIODIESEL



DIESEL



FOOD



GASOLINE



GREASE



KEROSENE



OIL



WATER



WINDSCREEN

CHART

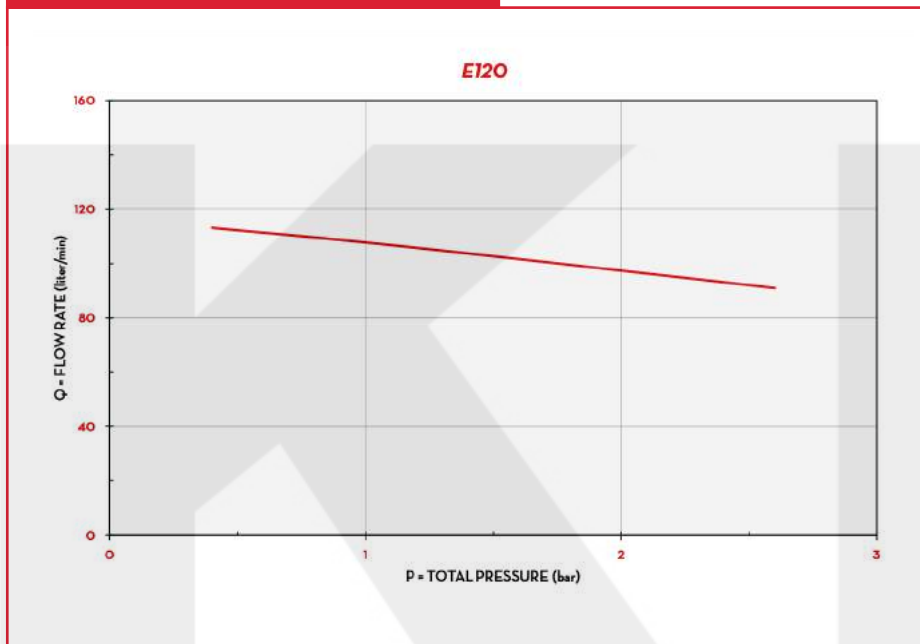

IN THE BOX

- SELF SERVICE FM 2.0 UNIT
- DELIVERY HOSE
- AUTOMATIC NOZZLE
- INSTRUCTION MANUAL

DETAILS



WATER CAPTOR FILTER (pag. 128)



SSM 2.0 SW (pag. 152)



USER&VEHICLE KEY (n.i.)

DIMENSIONS

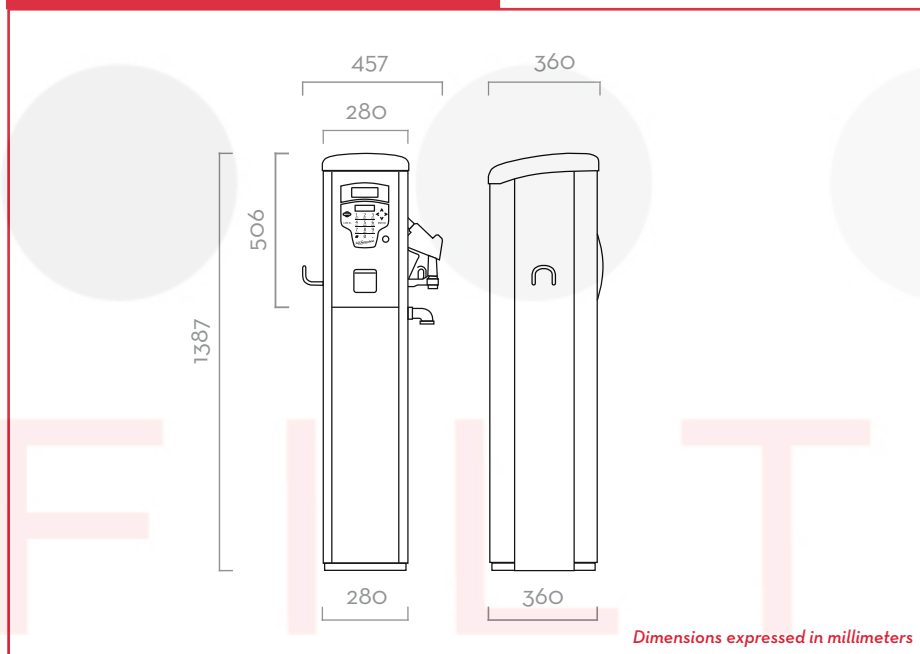

MATERIALS

- **PUMPS:**
E80 / E120 PAG. 68
- **METER:**
K600/3 PAG. 96
- **NOZZLE:**
AUTOMATIC NOZZLE PAG. 118
- **FILTER:**
WATER CAPTOR PAG. 128

TECHNICAL DATA

CODE	DESCRIPTION	FLUIDS TYPE	FLOW-RATE		VOLTAGE			PUMP	METER	NOZZLE	FILTER		INLET	SELF SERVICE MANAGEMENT 2.0
			L/MIN	GPM	AC V/HZ DC VOLT	POWER WATT	AMP. MAX.				H2O FILTER	FILTERING CAPACITY		
COLUMN VERSION														
FO074301A	SELF SERVICE 100 FM 2.0	D	90	24	230/50	1150	5,7	E120	K600	AUT.	YES	30µ	1" 1/2	REQUIRED



DISPENSERS



PUMPS



METERS



NOZZLE



FILTRATION



FLUID MONITORING

ST

FEATURES

- **RADY TO USE**
- **EASY TO INSTALL**
- **STURDY STRUCTURE**
- **COMPACT DEISGN**
- **AVAILABLE WITH DIFFERENT PUMPS**

The PIUSI ST is a versatile and compact diesel transfer station that can be used to fill mobile tanks or interact with distribution units. It is fitted with check valve, filter, nozzle and 4mt delivery hose. Its sturdy structure makes this dispenser suitable to be used in the harshest environments. It can be integrated with a protective metal box and water separating filter.

PERFORMANCE

UP TO

90 L/MIN

FLOW-RATE

AC/DC

VOLTAGE

POWER

4MT

LENGTH

DELIVERY HOSE



ST



PACKAGING

CODE	WEIGHT		PACKAGING		
	KG	LBS	MM	INCH	PCS/BOX
000266P00	16	35	357X357X275	14,1X14,1X10,8	1
000286P00	16	35	357X357X275	14,1X14,1X10,8	1
000266P20	21	46	357X357X275	14,1X14,1X10,8	1
000214000	21	46	357X357X275	14,2X14,2X11,8	1
000216000	23	50	480X370X265	18,9X14,6X10,4	1
000252000	23	50	480X370X265	18,9X14,6X10,4	1
000248000	20	44	357X357X275	14,1X14,1X10,8	1
FO021000B	10	22	357X357X275	14,1X14,1X10,8	1
FO021100B	10	22	357X357X275	14,1X14,1X10,8	1
FO0340080	19	42	357X357X275	14,1X14,1X10,8	1



HOSE REELS



ACCESSORIES



MERCHANDISE



AIR



ANTIFREEZE



AdBlue®



BIODIESEL



DIESEL



FOOD



GASOLINE



GREASE



KEROSENE



OIL



WATER



WINDSCREEN

AVAILABLE WITH DIFFERENT PUMPS

AC PUMP - PANTHER



AC PUMP - E80



AC PUMP - E120



AC PUMP - VISCOMAT VANE



DC PUMP - BP3000



DC PUMP - PANTHER DC

IN THE BOX

- ST UNIT
- DELIVERY HOSE
- NOZZLE
- NOZZLE HOLDER
- INSTRUCTION MANUAL

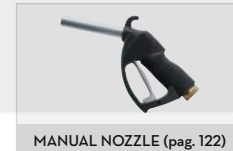
DETAILS

MANUAL NOZZLE (pag. 122)

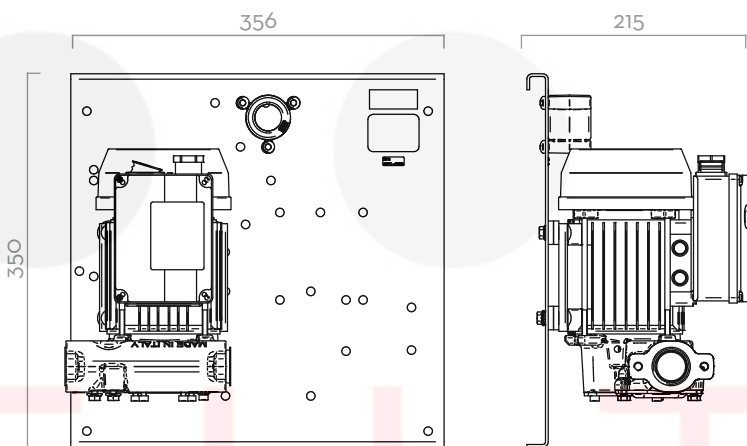

AUTOMATIC NOZZLE (pag. 118)

DIMENSIONS

Dimensions expressed in millimeters

COMPONENTS

- PUMP:

PANTHER AC	PAG. 64
E80/E120	PAG. 68
VISCOMAT VANE	PAG. 66
BP3000	PAG. 74
PANTHER DC	PAG. 78
- NOZZLE:

MANUAL NOZZLE	PAG. 122
AUTOMATIC NOZZLE	PAG. 118

TECHNICAL DATA

CODE	DESCRIPTION	FLUIDS TYPE	FLOW-RATE		VOLTAGE			METER	NOZZLE	FILTER	DELIVERY HOSE		INLET
			L/MIN	GPM	AC V/Hz	DC VOLT	POWER WATT				AMP. MAX.	LENGTH	
000266POO	ST PANTHER 56	D	56	15	230/50	350	3	NO	MAN.	NO	4M	3/4"	1"
000286POO	ST PANTHER 56 A60	D	56	15	230/50	350	3	NO	AUT.	NO	4M	3/4"	1"
000266P20	ST PANTHER 72/M	D	72	19	230/50	500	4,2	NO	MAN.	NO	4M	3/4"	1"
000214000	ST E 80	D	80	21	230/50	700	3,5	NO	MAN.	NO	4M	1"	1"
000216000	ST E 120	D	90	24	230/50	1150	5,7	NO	MAN.	NO	4M	1"	1"
000252000	ST E 120 A120	D	90	24	230/50	1150	5,7	NO	AUT.	NO	4M	1"	1"
000248000	ST VISCOMAT 70 (RAPSOIL)	B	30	8	230/50	950	4,6	NO	MAN.	NO	4M	1"	1"
FOO21000B	ST BYPASS 3000 12V	D	42	11	12	260	22	NO	MAN.	NO	4M	3/4"	1"
FOO21100B	ST BYPASS 3000 24V	D	42	11	24	300	12	NO	MAN.	NO	4M	3/4"	1"
FOO340080	ST PANTHER DC 12V	D	56	15	12	420	35	NO	MAN.	NO	4M	3/4"	1"

THE UNIT CAN ALSO BE SUPPLIED FOR OPERATING UNDER DIFFERENT VOLTAGES AND WITHOUT METER.



DISPENSERS



PUMPS



METERS



NOZZLE



FILTRATION



FLUID MONITORING

ST WITH METER

FEATURES

- **READY TO USE**
- **EASY TO INSTALL**
- **STURDY STRUCTURE**
- **HIGH PRECISION METER**
- **AVAILABLE WITH DIFFERENT PUMPS**

The PIUSI ST WITH METER is a diesel transfer station for fixed installations composed by AC or DC pump, nozzle (manual or automatic) and precision meter - both mechanical (K33) or electronic (K600/3 B) - for safe and controlled refueling operations. Easy to install, this station can be used to fill mobile tanks or interact with distribution units.

PERFORMANCE

UP TO

90 L/MIN

FLOW-RATE

AC/DC

VOLTAGE

POWER

± 1%

ACCURACY

4MT

LENGTH

DELIVERY HOSE



METALLIC BOX (optional)

ST WITH METER



PACKAGING

CODE	WEIGHT		PACKAGING		
	KG	LBS	MM	INCH	PCS/BOX
FO0385POA	16	35	357X357X275	14,1X14,1X10,8	1
FO0287POA	16	35	357X357X275	14,1X14,1X10,8	1
OO0390000	21	46	357X357X275	14,1X14,1X10,8	1
OO0392000	23	50	357X357X275	14,2X14,2X11,8	1
OO0395000	23	50	480X370X265	18,9X14,6X10,4	1
OO0395050	24	53	480X370X275	18,9X14,6X11,8	1
OO0397000	20	44	480X370X265	18,9X14,6X10,4	1
OO0256000	10	22	357X357X275	14,1X14,1X10,8	1
FO0287P40	19	41	357X357X275	14,1X14,1X10,8	1
FO023500B	13	29	357X357X275	14,1X14,1X10,8	1
FO023600B	13	29	357X357X275	14,2X14,2X11,8	1
FO023300B	14	31	480X370X265	18,9X14,6X10,4	1
FO023400B	14	31	480X370X265	18,9X14,6X10,4	1
FO024000A	24	53	357X357X275	14,1X14,1X10,8	1
FO024003A	24	53	357X357X275	14,1X14,1X10,8	1
FO024100A	24	53	357X357X275	14,1X14,1X10,8	1
FO024101A	11	11	357X357X275	14,1X14,1X10,8	1
FO0340070	17	37	357X357X275	14,1X14,1X10,8	1
FO0340160	17	11	357X357X275	14,1X14,1X10,8	1



HOSE REELS



ACCESSORIES



MERCHANDISE



AIR



ANTIFREEZE



AdBlue®



BIODIESEL



DIESEL



FOOD



GASOLINE



GREASE



KEROSENE



OIL



WATER



WINDSCREEN

AVAILABLE WITH DIFFERENT PUMPS

AC PUMP - PANTHER 56/72



AC PUMP - E80/E120



AC PUMP - VISCOMAT 70/90



DC PUMP - BYPASS 3000



DC PUMP - PANTHER DC



DC PUMP - BIPUMP

IN THE BOX

- ST UNIT
- METER
- DELIVERY HOSE
- NOZZLE
- NOZZLE HOLDER
- INSTRUCTION MANUAL

DETAILS

K33



MAN. / AUTOM. NOZZLE

COMPONENTS

- PUMP:
 - PANTHER AC PAG. 64
 - E80/E120 PAG. 68
 - VISCOMAT VANE PAG. 66
 - BP3000 PAG. 74
 - PANTHER DC PAG. 78
 - BIPUMP PAG. 80
- NOZZLE:
 - MANUAL NOZZLE PAG. 122
 - AUTOMATIC NOZZLE PAG. 118
- METER:
 - K33 PAG. 108

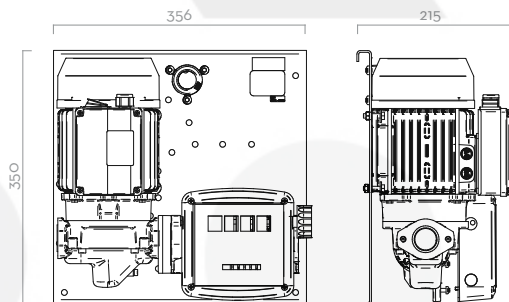
DIMENSIONSDimensions expressed
in millimeters**TECHNICAL DATA**

CODE	DESCRIPTION	FLUIDS TYPE	FLOW-RATE		VOLTAGE			METER	NOZZLE	INLET
			L/MIN	GPM	AC V/HZ DC VOLT	POWER WATT	AMP. MAX.			
FO0385POA	ST PANTHER 56 K33	D	56	15	230/50	350	3	K33	MAN.	3/4"
FO0287POA	ST PANTHER 56 K33 A60	D	56	15	230/50	350	3	K33	AUT.	3/4"
OO0390000	ST E80 K33	D	80	21	230/50	700	3,5	K33	MAN.	1"
OO0392000	ST E80 K33 A80	D	75	20	230/50	700	3,5	K33	AUT.	1"
OO0395000	ST E120 K33	D	90	24	230/50	1150	5,7	K33	MAN.	1"
OO0395050	ST E120/M K44	D	90	24	230/50	1150	5,7	K44	MAN.	1"
OO0397000	ST E120 K33 A120	D	90	24	230/50	1150	5,7	K33	AUT.	1"
OO0256000	ST VISCOMAT 70 K33 (RAPSOIL)	B	30	8	230/50	950	4,6	K33	MAN.	1"
OO0287P40	ST PANTHER 72/M K33 A80	D	72	19	230/50	500	4,2	K33	AUT.	1"
FO023500B	ST BYPASS 3000/12V K33	D	40	10	12	260	22	K33	MAN.	3/4"
FO023600B	ST BYPASS 3000 INLINE 24V K33	D	40	10	24	300	12	K33	MAN.	3/4"
FO023300B	ST BYPASS 3000/12V K33 A60	D	35	9	12	260	22	K33	AUT.	3/4"
FO023400B	ST BYPASS 3000 INLINE 24V K33 A60	D	35	9	24	300	12	K33	AUT.	3/4"
FO024000A	ST BI-PUMP 12V K33 SELF 3000	D	80	21	12	530	44	K33	MAN.	1"
FO024003A	ST BI-PUMP 12V K33 A120	D	80	21	12	530	44	K33	AUT.	1"
FO024100A	ST BI-PUMP 24V K33 SELF 3000	D	80	21	24	540	22,5	K33	MAN.	1"
FO024101A	ST BI-PUMP 24V K33 A120	D	80	21	24	540	22,5	K33	AUT.	1"
FO0340070	ST PANTHER 12V K33 A60	D	56	15	12	420	35	K33	AUT.	3/4"
FO0340160	ST PANTHER DC 12/24V K33 A60	D	70/35	18,5/9,2	24/12	420/150	25/16	K33	AUT.	3/4"

ST WITH METER



DISPENSERS



PUMPS



METERS



NOZZLE



FILTRATION



FLUID MONITORING

ST WITH METER and FILTER

FEATURES

- **READY TO USE**
- **VERSATILE**
- **EASY TO INSTALL**
- **COMPACT DESIGN**
- **FILTRATION GUARANTEED**
- **AVAILABLE WITH DIFFERENT PUMPS**

PIUSI ST WITH METER AND FILTER is a range of dispensers particularly suited for all applications in which a filtration is required. The stations integrate PIUSI clear or water captor filters and are available with mechanical meter K33 or electronic meter K24. They come with integrated check valve and 4-meter delivery hose.

PERFORMANCE

UP TO

90 L/MIN

FLOW-RATE

AC

CONTINUOUS DUTY

POWER

± 1%

ACCURACY

6MT

LENGTH

DELIVERY HOSE



FILL



ST PANTHER 56, K33, A60 AND WATER CAPTOR

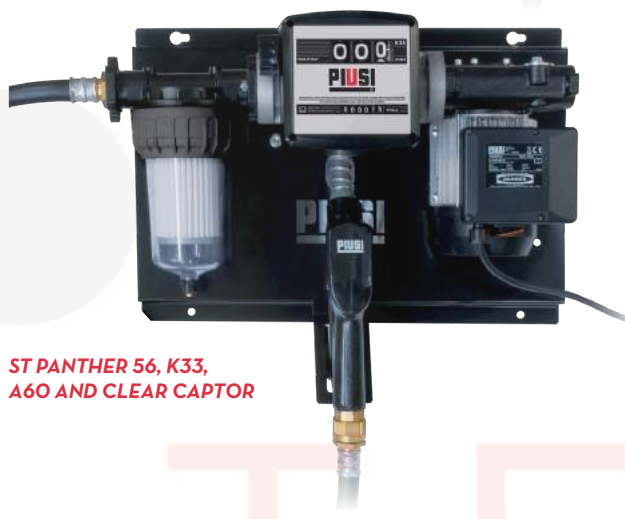

ST PANTHER 56, K33, A60 AND CLEAR CAPTOR

PACKAGING

CODE	WEIGHT		PACKAGING		
	KG	LBS	MM	INCH	PCS/BOX
FO0386FOA	25	55	580X380X320	22,8X15X12,6	1
FO0265F3A	25	55	580X380X320	22,8X15X12,6	1
FO0265FOA	26	57	580X380X320	22,8X15X12,6	1
FO0395FOA	32	71	545X435X340	21,5X17,1X13,4	1
FO0386F60	22	48	380X380X480	15X15X18,9	1
TF00386R70	22	48	380X380X480	15X15X18,9	1
FO0265F40	26	57	580X380X320	22,8X15X12,6	1
FO0265S80	26	57	580X380X320	22,8X15X12,6	1
FO0395F60	32	71	545X435X340	21,5X17,1X13,4	1
FO0265S20	18	40	480X370X260	18,9X14,6X10,2	1
FO0265R70	18	40	480X370X260	18,9X14,6X10,2	1



HOSE REELS



ACCESSORIES



MERCHANDISE



AIR



ANTIFREEZE



AdBlue®



BIODIESEL



DIESEL



FOOD



GASOLINE



GREASE



KEROSENE



OIL



WATER



WINDSCREEN

DIFFERENT CONFIGURATIONS

AC PUMP - PANTHER 56/72



AC PUMP - E120



AUTOMATIC NOZZLE



MECHANICAL METER - K33



ELECTRONIC METER - K24



K600 B/3

IN THE BOX

- ST UNIT
- METER
- FILTER
- DELIVERY HOSE
- NOZZLE
- NOZZLE HOLDER
- INSTRUCTION MANUAL

DETAILS

WATER CAPTOR FILTER (pag. 128)



MAN. / AUTOM. NOZZLE

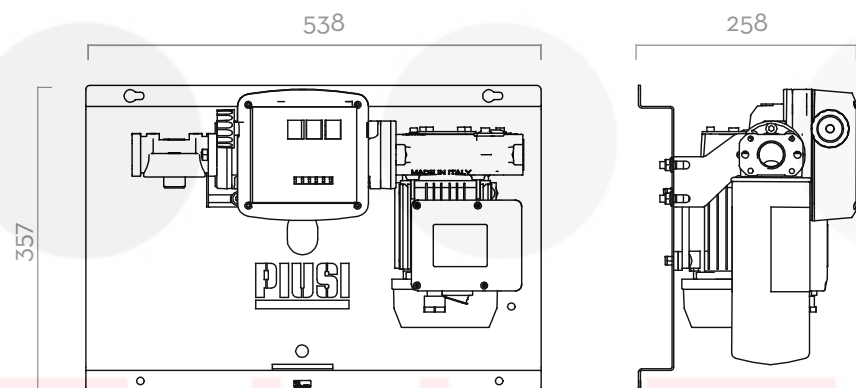

K24 / K33 METER

DIMENSIONS

Dimensions expressed in millimeters

COMPONENTS

- **PUMP:**
PANTHER AC PAG. 64
E80/E120 PAG. 68
- **NOZZLE:**
AUTOMATIC NOZZLE PAG. 118
- **METER:**
K33 PAG. 108
K24 PAG. 94
K600 B/3 PAG. 98
- **FILTER**
WATER CAPTOR PAG. 128

TECHNICAL DATA

CODE	DESCRIPTION	FLUIDS TYPE	FLOW-RATE		VOLTAGE			METER	NOZZLE	FILTER	DELIVERY HOSE	SUCTION HOSE		INLET
			L/MIN	GPM	AC V./HZ	DC VOLT	POWER WATT					AMP. MAX.	LENGTH	
FOO386FOA	ST PANTHER 56 FILTER + A6O	D	52	14	230/50	350	3	K33	AUT.	YES	6M	3/4"	4M	1"
FOO265F3A	ST PANTHER 72 + CLEAR CAPTOR + A6O	D	70	14	230/50	500	4,2	K33	AUT.	YES	6M	3/4"	4M	1"
FOO265FOA	ST PANTHER 72 FILTER + A6O	D	70	18	230/50	500	4,2	K33	AUT.	YES	6M	3/4"	4M	1"
FOO395FOA	ST E120 FILTER + A12O	D	85	22	230/50	1150	5,7	K33	AUT.	YES	6M	1"	4M	1"
FOO386F6O	ST PANTHER 56 FILTER + A6O	D	52	14	230/50	350	3	K33	AUT.	YES	6M	3/4"	6M	1"
FOO386R7O	ST PANTHER 56 + CLEAR CAPTOR + A6O	D	52	14	230/50	350	3	K33	AUT.	YES	6M	3/4"	6M	1"
FOO265F4O	ST PANTHER 72 FILTER + A6O	D	70	18	230/50	500	4,2	K33	AUT.	YES	6M	3/4"	6M	1"
FOO265S8O	ST PANTHER 72 K600 B/F/6T/PA6O	D	70	18	230/50	500	4,2	K600 B/3	AUT.	YES	6M	1"	-	1"
FOO395F6O	ST E 120 FILTER + A12O	D	85	22	230/50	1150	5,7	K33	AUT.	YES	6M	1"	6M	1"
FOO265S2O	ST PANTHER 72 FILTER + K24 METER	D	70	18	230/50	500	4,2	K24	AUT.	YES	6M	3/4"	6M	1"
FOO265R7O	ST PANTHER 72 + CLEAR CAPTOR + A8O	D	70	18	230/50	500	4,2	K24	AUT.	YES	6M	1"	6M	1"

ST WITH METER AND FILTER



DISPENSERS



PUMPS



METERS



NOZZLE



FILTRATION



FLUID MONITORING

ST BOX

FEATURES

- **STURDY STRUCTURE**
- **LOCKABLE AND SAFE**
- **READY TO USE**
- **FILTRATION GUARANTEED**
- **NOZZLE CONTACT (PRO VERSION ONLY)**

The PIUSI ST BOX is a diesel refueling station complete with pump, flow meter and filter, with lockable metal protection box. The unit is complete with antistatic hose for diesel fuel and automatic dispensing nozzle. The Pro version features the electronic access control box Access 85.

PERFORMANCE

UP TO

90 L/MIN

FLOW-RATE

AC

CONTINUOUS DUTY

POWER

± 1%

ACCURACY



ST BOX PRO



ST BOX BASIC



PACKAGING

CODE	WEIGHT		PACKAGING		
	KG	LBS	MM	INCH	PCS/BOX
WITHOUT ACCESS 85					
00036700B					
00036900B					
FO0365020					
FO0365060					
FO0365050	36	72	575X320X607	22,6X12,6X23,9	1
FO0365POA	40	88	575X320X607	22,6X12,6X23,9	1
FO039900A	50	110	590X340X720	23,2X13,4X28,3	1
WITH ACCESS 85					
FO0365010	40	88	575X320X607	22,6X12,6X23,9	1



HOSE REELS



ACCESSORIES



MERCHANDISE



AIR



ANTIFREEZE



AdBlue®



BIO DIESEL



DIESEL



FOOD



GASOLINE



GREASE



KEROSENE



OIL



WATER



WINDSCREEN

CHART

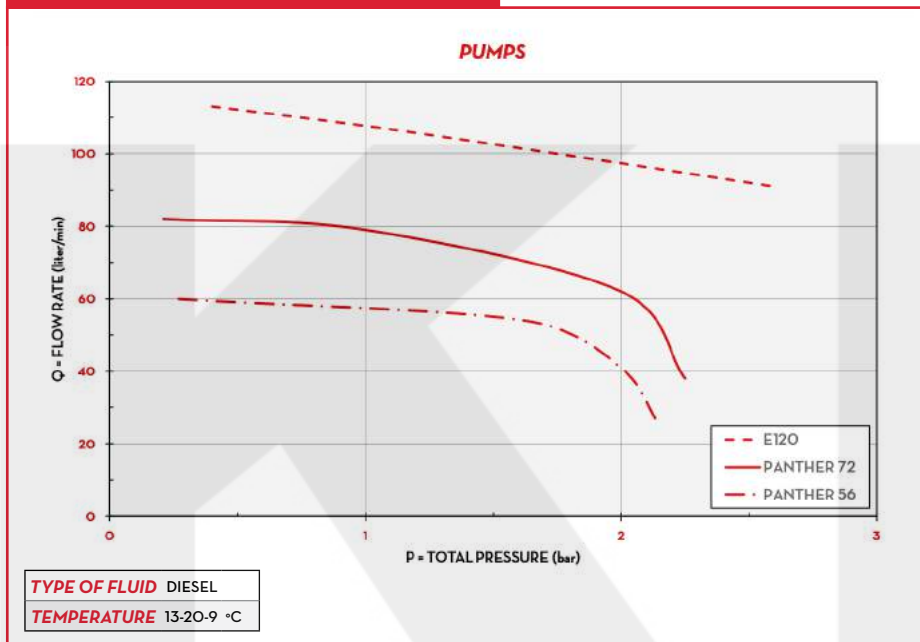

IN THE BOX

- ST UNIT
- METER
- FILTER
- DELIVERY HOSE
- NOZZLE
- INSTRUCTION MANUAL

DETAILS



K33 MECH. METER (pag. 108)



WATER CAPTOR FILTER (pag. 128)



DRIVER&MANAGER KEY*



ACCESS85 (pag. 142)

DIMENSIONS

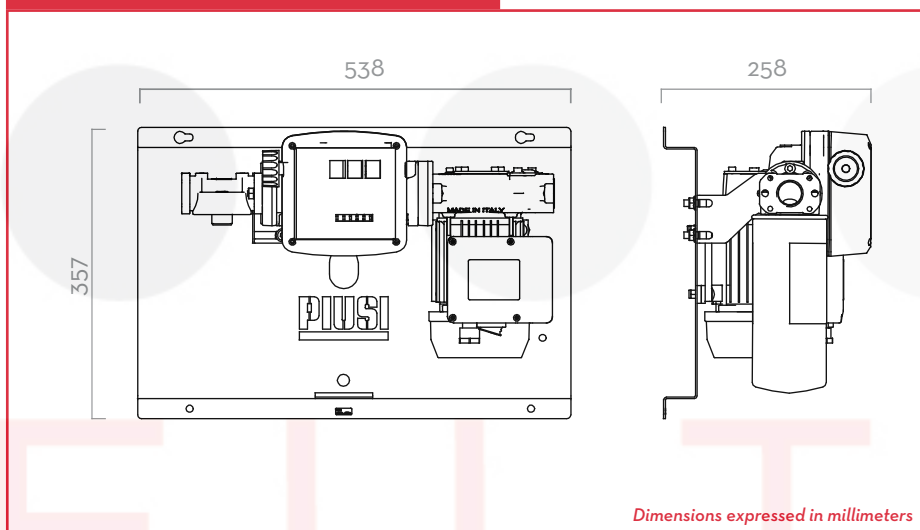

COMPONENTS

- **PUMP:**
 - PANTHER AC PAG. 64
 - E80/E120 PAG. 68
 - BIPUMP PAG. 80
- **NOZZLE:**
 - AUTOMATIC NOZZLE PAG. 118
- **METER:**
 - K33 PAG. 108
 - K24 PAG. 94
- **FILTER**
 - WATER CAPTOR PAG. 128
- **ACCESSOCONTROL**
 - ACCESS85 PAG. 142

TECHNICAL DATA

CODE	DESCRIPTION	FLUIDS TYPE	FLOW-RATE		VOLTAGE			PUMP TYPE	METER TYPE	NOZZLE TYPE	FILTER H2O FILTER	HOSE		INLET BSP
			L/MIN	GPM	AC V/HZ DC VOLT	POWER WATT	AMP. MAX.					LENGTH	Ø	
WITHOUT ACCESS 85														
00036700B	ST BOX E80/M K33 A80	D	80	21	230/50	500	3,5	E80	K33	AUT.	NO	4M	1"	1"
00036900B	ST BOX E120/M K33 A120	D	90	22	230/50	750	5,7	E120	K33	AUT.	NO	4M	1"	1"
FO0365020	ST BOX PANTHER 56 BASIC	D	56	15	230/50	350	3	PANTH. 56	K33	AUT.	YES	6M	1"	1"
FO0365060	ST BOX PANTHER 72 BASIC	D	70	19	230/50	500	4,2	PANTH. 72	K33	AUT.	YES	6M	1"	1"
FO0365050	ST BOX E 120 BASIC	D	90	22	230/50	750	5,7	E 120	K33	AUT.	YES	8M	1"	1"
FO0365POA	ST BOX P56/M K33 A60	D	56	15	230/50	350	3	PANTH. 56	K33	AUT.	NO	4M	3/4"	1"
FO039900A	ST BOX BI-PUMP 12V K33 A120	D	80	21	12	530	44	BIPUMP	K33	AUT.	NO	4M	1"	1"
WITH ACCESS 85														
FO0365010	ST BOX PANTHER 72 PRO	D	70	19	230/50	500	4,2	PANTH. 72	K24	AUT.	YES	6M	1"	1"

*PRO VERSION ONLY



DISPENSERS



PUMPS



METERS



NOZZLE



FILTRATION



FLUID MONITORING

ST 200 AC

FEATURES

- STURDY METALLIC FRAME
- READY TO USE
- EASY TO MOVE
- HEAVY DUTY

The PIUSI ST 200 AC is a dispenser that allows high flow refueling thanks to the two integrated E120 self-priming rotary electric vane pumps. Fitted with by-pass valve and elevated reliability seal, the dispenser works even at low working temperatures and in every condition on worksites. The oval gear mechanical flow meter guarantees great precision (available on request). It is also available with wheels and handle (on request) for easier handling.

PERFORMANCE

UP TO
200 L/MIN

FLOW-RATE

AC
CONTINUOUS DUTY

POWER



ST 200 AC

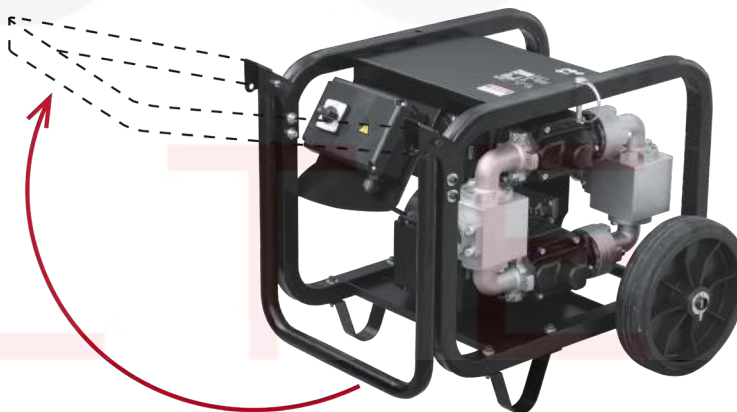

HANDY KIT: VERSION WITH WHEELS AND HANDLE

PACKAGING

CODE	WEIGHT		PACKAGING		
	KG	LBS	MM	INCH	PCS/BOX
FO0315000	46	101	587X395X420	23,1X15,6X16,5	1
F16860000	-	-	-	-	-



HOSE REELS



ACCESSORIES



MERCHANDISE



AIR



ANTIFREEZE



AdBlue®



BIODIESEL



DIESEL



FOOD



GASOLINE



GREASE



KEROSENE



OIL



WATER



WINDSCREEN

CHART

ST 200 AC

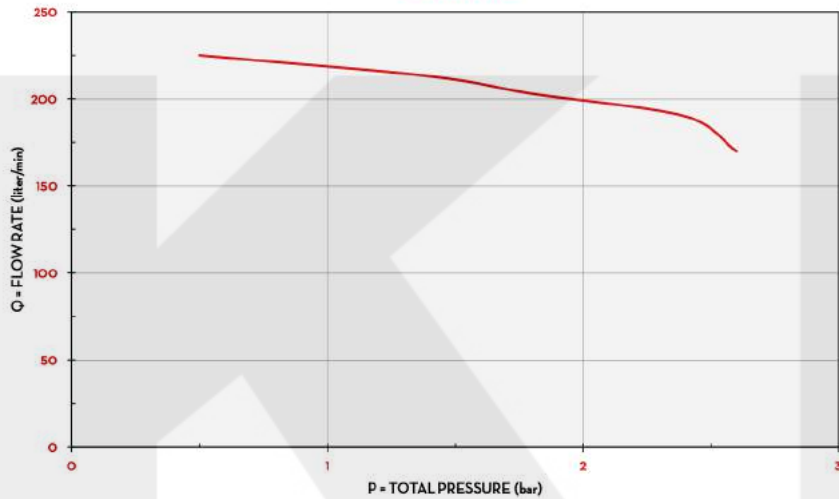

TYPE OF FLUID DIESEL

TEMPERATURE 13 °C

IN THE BOX

- ST 200 AC UNIT
- INSTRUCTION MANUAL

DETAILS



ON/OFF SWITCH

DIMENSIONS

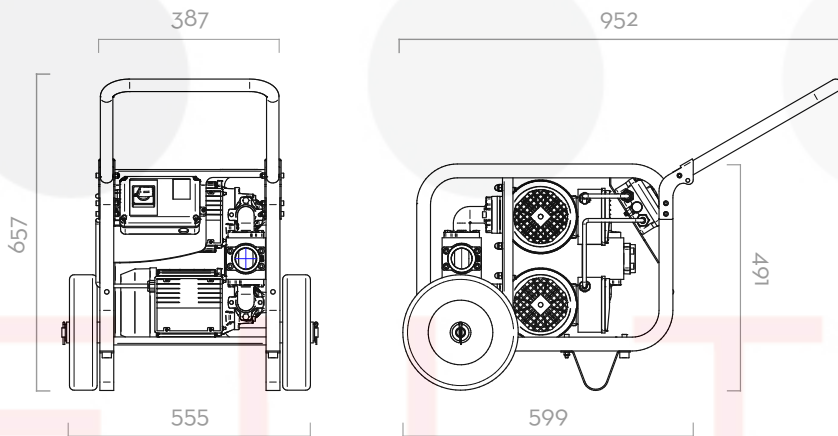

Dimensions expressed in millimeters

MATERIALS

- BODY: CAST IRON
- ROTOR: SINTERED STEEL
- VANES: ACETAL RESIN
- SEAL: VITON
- SHAFT: STEEL

TECHNICAL DATA

CODE	DESCRIPTION	FLUIDS TYPE	FLOW-RATE		VOLTAGE			PUMP		MAX PRESSURE BAR	INLET BSP
			L/MIN	GPM	AC V/HZ DC VOLT	POWER WATT	AMP. MAX.	TYPE	N°		
FO0315000	ST 200 BASIC	D	200	52,7	230/50	2050	10	E 120	2	2,5	1" 1/2
F16860000	HANDY KIT (HANDLE + WHEELS)	D	-	-	-	-	-	-	-	-	-



DISPENSERS



PUMPS



METERS



NOZZLE



FILTRATION



FLUID MONITORING

ST 200 DC

FEATURES

- STURDY STRUCTURE
- COMPACT DESIGN
- READY TO USE
- HIGH RELIABILITY
- HEAVY DUTY

PIUSI ST 200 DC is a 24V portable dispensing unit for high flow applications. The low weight of the unit makes it easy to handle and suitable for operating on worksites in every condition; both on tanks or for mobile applications. Thanks to the mechanical meter K700, this sturdy dispenser guarantees the maximum precision (on request).

PERFORMANCE

UP TO
185 L/MIN

FLOW-RATE

24V

VOLTAGE
POWER

20 MIN

(40MIN OFF)
DUTY CYCLE



ST 200 DC



PACKAGING

CODE	WEIGHT		PACKAGING		
	KG	LBS	MM	INCH	PCS/BOX
FO0318000	18	40	480X370X265	18,9X14,6X10,4	1



HOSE REELS



ACCESSORIES



MERCHANDISE



AIR



ANTIFREEZE



AdBlue®



BIODIESEL



DIESEL



FOOD



GASOLINE



GREASE



KEROSENE



OIL



WATER



WINDSCREEN

CHART

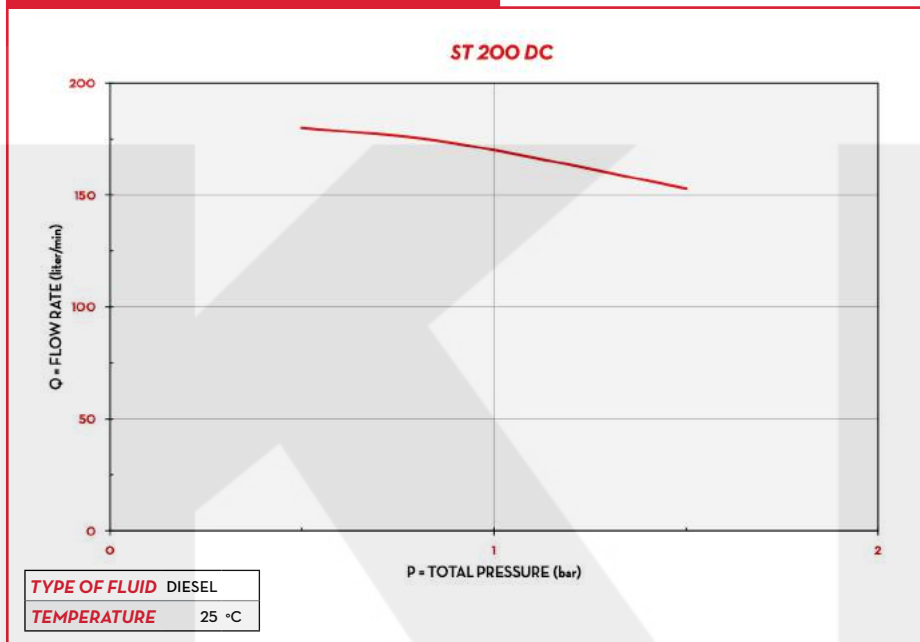

IN THE BOX

- ST 200 DC UNIT
- ELECTRIC CABLE WITH CLAMPS
- INSTRUCTION MANUAL

DETAILS



ON/OFF SWITCH



ELECTRIC CABLE

DIMENSIONS

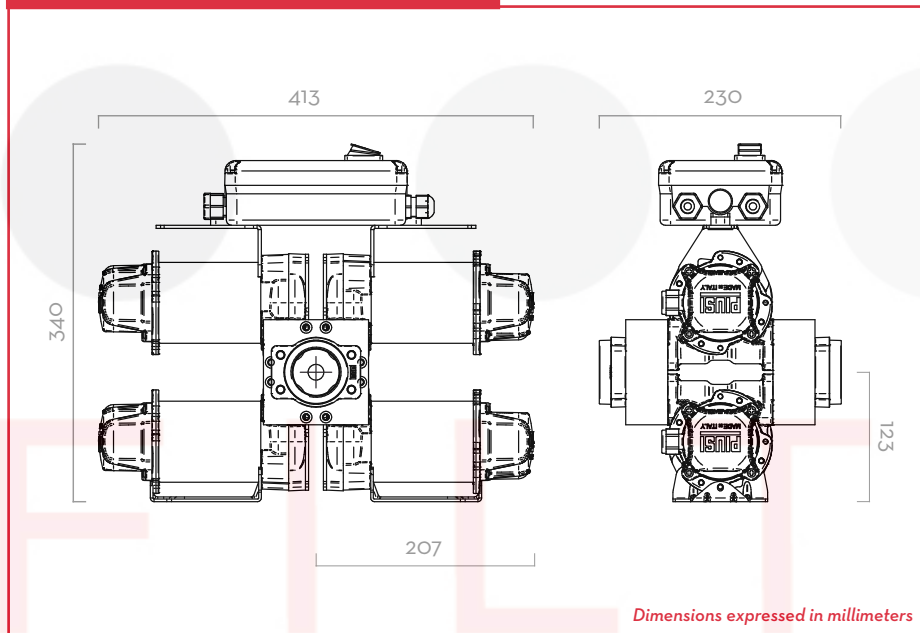

MATERIALS

- BODY: CAST IRON
- ROTOR: SINTERED STEEL
- VANES: ACETAL RESIN
- SEAL: NBR
- SHAFT: STEEL

TECHNICAL DATA

CODE	DESCRIPTION	FLUIDS TYPE	FLOW-RATE		VOLTAGE			DUTY CYCLE	PUMP		MAX PRESSURE	INLET
			L/MIN	GPM	AC V/HZ	DC VOLT	POWER WATT	AMP. MAX.	MINUTES	TYPE	N°	BAR
FO0318000	ST 200 DC 24 V	D	185	42-48	24	1200	50	30	BYPASS 3000	4	2	1" 1/2

ST 200 DC



DISPENSERS ACCESSORIES

ATEX

EX50 DRUM	CODE	DESCRIPTION
	R1862400A	(EX) CABLE GLAND EXD1/2NPT ATEX\IECEX
	R1815600A	(EX) ADAPTER FOR CONDUIT ATEX EX50
	F18626000	(EX)CABLE+CABLEGLAND ATEX\IECEX EX50 12V

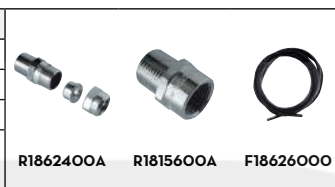



EX50 ST	CODE	DESCRIPTION
	R1862400A	(EX) CABLE GLAND EXD1/2NPT ATEX\IECEX
	R1815600A	(EX) ADAPTER FOR CONDUIT ATEX EX50

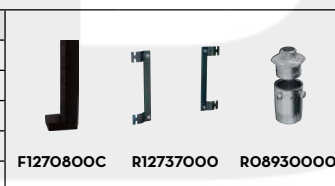

CUBE

CUBE	CODE	DESCRIPTION
	F1270800C	KIT PEDESTAL CUBE BLACK
	R12737000	WALL KIT
	R08930000	KIT QUICK COUPLING 2IN X 1IN
	F17163000	2" BSP DRUM CONNECTOR WITH VALVE
	R12738000	KIT PADLOCK CUBE MC



CUBE MC	CODE	DESCRIPTION
	F1270800C	KIT PEDESTAL CUBE BLACK
	R12737000	WALL KIT
	R08930000	KIT QUICK COUPLING 2IN X 1IN
	F17163000	2" BSP DRUM CONNECTOR WITH VALVE
	R12738000	KIT LOCK CUBE MC
	F1590400A	KIT DRIVER KEY YELLOW (10PCS)
	F1249600A	MANAGER KEY 2018



CUBE MC 2.0	CODE	DESCRIPTION
	F1270800C	KIT PEDESTAL CUBE BLACK
	R12737000	WALL KIT
	R08930000	KIT QUICK COUPLING 2IN X 1IN
	F17163000	2" BSP DRUM CONNECTOR WITH VALVE
	R12738000	KIT PADLOCK CUBE MC
	F1590400A	KIT DRIVER KEY YELLOW (10PCS)
	F17299000	KIT VEHICLE KEY BLUE (10PCS)



MOBILE

BATTERY KIT	CODE	DESCRIPTION
	F16586000	DRUM 3000 KIT
	F16631000	KIT DRUM 3000 K33 / FILTER / ADAPTER



F16586000

PIUSIBOX	CODE	DESCRIPTION
	R20764000	K24 ASSEMBLY KIT FOR PIUSIBOX N.
	F16483010	CARTRIDGE 10 MICRON 3/4IN PIUSI BOX 15PC



R20764000



F16483010

SELF SERVICE

SELF SERVICE MC	CODE	DESCRIPTION
	F1590400A	KIT DRIVER KEY YELLOW (10PCS)
	F1249600A	MANAGER KEY 2018
	FO0773010	SELF SERVICE 2018 - USB
	FO0773210	SELF SERVICE 2018 - WEB



F1590400A



F1249600A



FO0773010
FO0773210

SELF SERVICE MC 2.0	CODE	DESCRIPTION
	F1590400A	KIT DRIVER KEY YELLOW (10PCS)
	F17299000	KIT VEHICLE KEY BLUE (10PCS)



F1590400A



F17299000

SELF SERVICE FM	CODE	DESCRIPTION
	F1590400A	KIT DRIVER KEY YELLOW (10PCS)
	F1249600A	MANAGER KEY 2018
	FO0773010	SELF SERVICE 2018 - USB
	FO0773210	SELF SERVICE 2018 - WEB



F1590400A



F1249600A



FO0773010
FO0773210

SELF SERVICE FM 2.0	CODE	DESCRIPTION
	F1590400A	KIT DRIVER KEY YELLOW (10PCS)
	F17299000	KIT VEHICLE KEY BLUE (10PCS)



F1590400A







F17299000



DISPENSERS ACCESSORIES



ST

ST BOX	CODE	DESCRIPTION
	F17121000	LEVEL PROBE FOR ACCESS 85
	F1249600A	MANAGER KEY 2018
	F1590400A	KIT DRIVER KEY YELLOW (10PCS)







F17121000
F1249600A
F1590400A

ST 200 AC	CODE	DESCRIPTION
	F18798000	KIT HOSE 1 1/2" 10 MT+CAMLOCK+HOSETAIL
	F18799000	KIT HOSE 1 1/2" 20 MT+CAMLOCK+HOSETAIL
	F16860000	KIT WHEELS \ HANDLE ST200

F18798000
F18799000
F16860000

ST 200 DC	CODE	DESCRIPTION
	F18798000	KIT HOSE 1 1/2" 10 MT+CAMLOCK+HOSETAIL
	F18799000	KIT HOSE 1 1/2" 20 MT+CAMLOCK+HOSETAIL

F18798000
F18799000

FILTER





KKD

PUMPS

FILTER





DISPENSERS



PUMPS



METERS



NOZZLE



FILTRATION



FLUID
MONITORING

EX50

FEATURES

- COMPACT AND STURDY DESIGN
- FLANGED COMPONENTS
- ANTI-NOISE FILTER
- THERMAL PROTECTION
- SUCTION UNIT WITH INTEGRATED FILTER (DRUM VERSION)
- UL VERSION AVAILABLE

The PIUSI EX50 is a compact and sturdy pump that satisfies the strictest ATEX/IECEx requirements concerning the usage of this equipment in potentially explosive atmospheres. It is equipped with built-in bypass valve, non-return valve and anti-noise filter.

PERFORMANCE

UP TO

50 L/MIN

FLOW-RATE

AC/DC

VOLTAGE

POWER

30 MIN

(30MIN OFF)

DUTY CYCLE

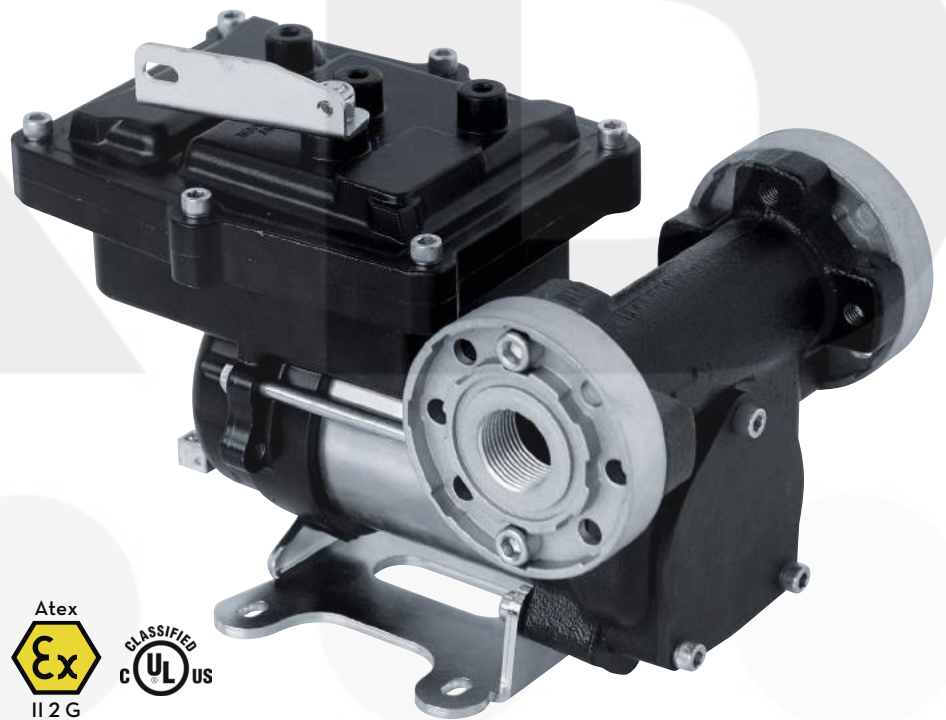



EX50 PUMP



OUR PUMPS COMPLIES WITH THE FOLLOWING MARKING ATEX/IECEx

II	2	G	Ex	d	db	IIA	IIB	T ₄	Gb
GROUP	CATEGORY	TYPE OF EXPLOSIVE ATMOSPHERE	PERMANENT PREFIX	PROTECTION METHOD	GAS GLASS	TEMPERATURE CLASS	EQUIPMENT PROTECTION LEVEL		
EX50	EX75	EX50	EX75						

PACKAGING

CODE	WEIGHT		PACKAGING			N. BOXES / EUROPALLET	
	KG	LBS	MM	INCH	PCS/BOX		
FO0371000	6,9	15,2	345X175X225	-	1	60	84
FO037300A	6,9	15,2	345X175X225	-	1	60	84



HOSE REELS



ACCESSORIES



MERCHANDISE



AIR



ANTIFREEZE



AdBlue®



BIODIESEL



DIESEL



FOOD



GASOLINE



GREASE



KEROSENE



OIL



WATER



WINDSCREEN

CHART

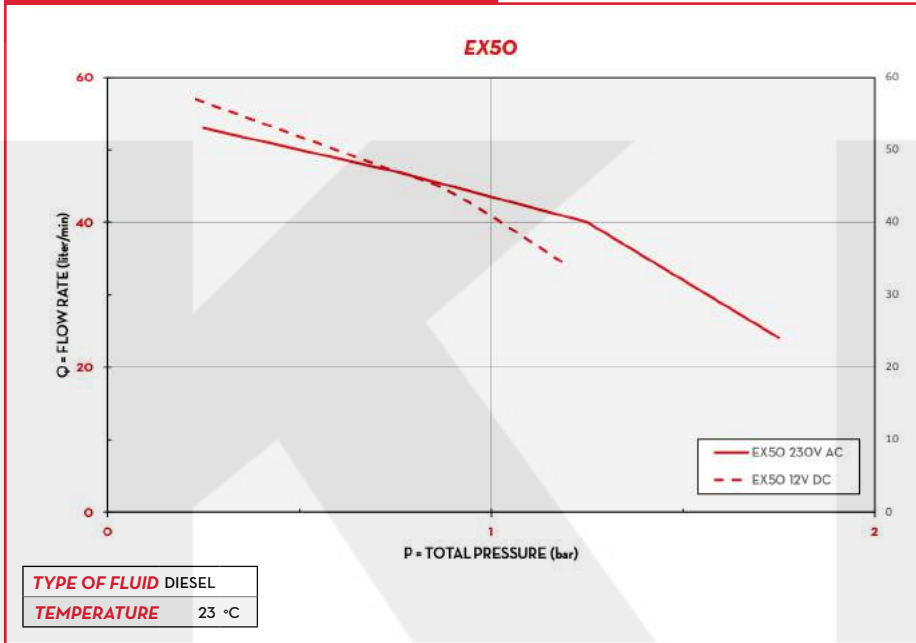

IN THE BOX

- EX50 PUMP
- FLANGED CONNECTIONS
- INSTRUCTION MANUAL

DETAILS



ON/OFF SWITCH



FLANGED CONNECTIONS

DIMENSIONS

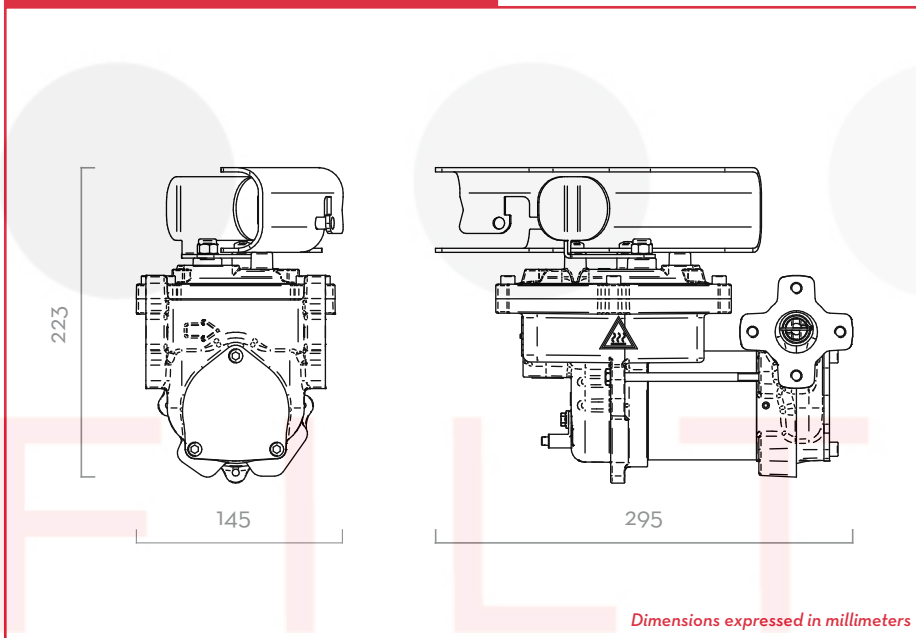

MATERIALS

- BODY: CAST IRON
- ROTOR: SINTERED STEEL
- VANES: PPS
- SEAL: VITON
- SHAFT: STEEL



PUMP

- MAX 6M (20FT),
- SUCTION HOSE Ø 1" MIN,
- MAX SUCTION HEIGHT:
 - 2M (7FT)
 - W/O NON RETURN VALVE
 - 4M (14FT) W NON RETURN VALVE



TANK

TECHNICAL DATA

CODE	DESCRIPTION	FLUIDS TYPE	FLOW-RATE		VOLTAGE			DUTY CICLE	RPM	INLET
			L/MIN	GPM	AC VOLT/HZ	POWER WATT	AMP. MAX.	MINUTES		BSP
FO0371000	EX50 12V DC ATEX	D G K	50	13	12	250	21	1"	2700	1"
FO037300A	EX50 230V AC ATEX	D G K	50	13	230/50-60	250	1	1"	2700	1"

(*) UPON REQUEST IT IS AVAILABLE WITH DIFFERENT VOLTAGES AND 60 HZ FREQUENCY. THE PUMP CAN BE USED ONLY WITH THE FOLLOWING FLUIDS: DIESEL, KEROSENE, PETROL, PETROL ALCOHOL MIXED MAX 15%, AVGAS 100/100LL (PUMP ONLY), JET A/A1 (PUMP ONLY) - ASPEN 2/4

EX50



DISPENSERS



PUMPS



METERS



NOZZLE



FILTRATION



FLUID MONITORING

EX75

FEATURES

- COMPACT AND STURDY DESIGN
- FLANGED COMPONENTS
- ANTI-NOISE FILTER
- THERMAL PROTECTION
- SUCTION UNIT WITH INTEGRATED FILTER (DRUM VERSION)
- UL LISTED MOTOR AVAILABLE

The PIUSI EX75 is a transfer pump suitable for flammable fuels such as petrol, kerosene and diesel. It is fully compliant with ATEX/IECEx requirements for the usage in potentially explosive atmospheres. Designed to transfer flammable fluids from tanks of any type, this pump is available in DC version, and is fitted with a bypass valve and can dispense up to 75 l/min, with reduced absorption to ensure a long life to the pump.

PERFORMANCE

UP TO
75 L/MIN

FLOW-RATE

12V
VOLTAGE

POWER

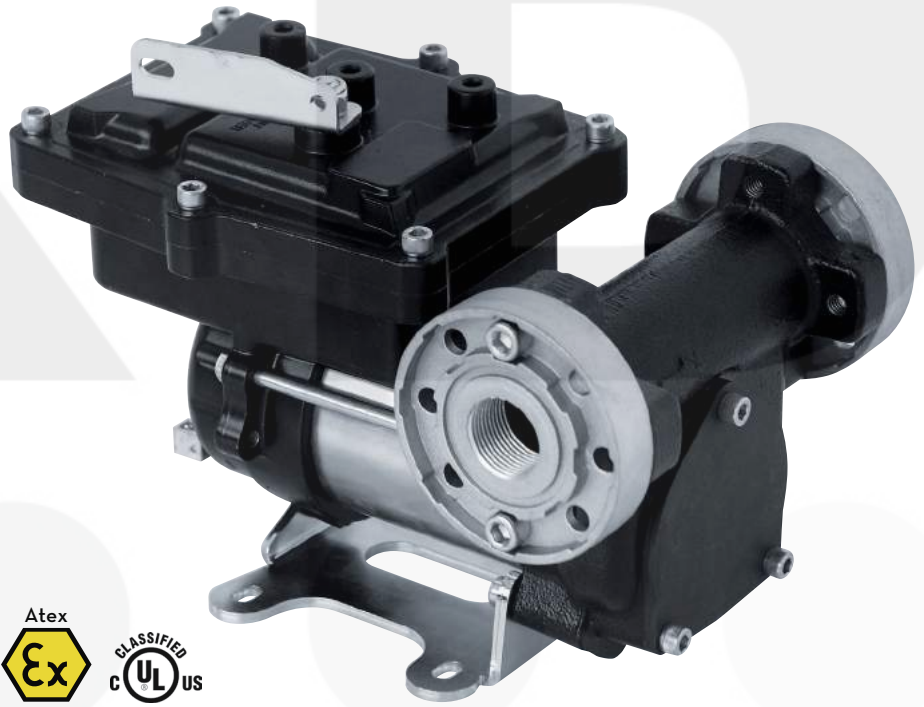



EX75



OUR PUMPS COMPLIES WITH THE FOLLOWING MARKING ATEX/IECEx

II	2	G	Ex	d	db	IIA	IIB	T4	Gb
GROUP	CATEGORY	TYPE OF EXPLOSIVE ATMOSPHERE	PERMANENT PREFIX	PROTECTION METHOD		GAS GLASS		TEMPERATURE CLASS	EQUIPMENT PROTECTION LEVEL

PACKAGING

CODE	WEIGHT		PACKAGING			N. BOXES / EUROPALLET	
	KG	LBS	MM	INCH	PCS/BOX		
FO0380000	8	17,8	350X185X260	-	1	60	84



HOSE REELS



ACCESSORIES



MERCHANDISE



AIR



ANTIFREEZE



AdBlue®



BIODIESEL



DIESEL



FOOD



GASOLINE



GREASE



KEROSENE



OIL



WATER



WINDSCREEN

CHART

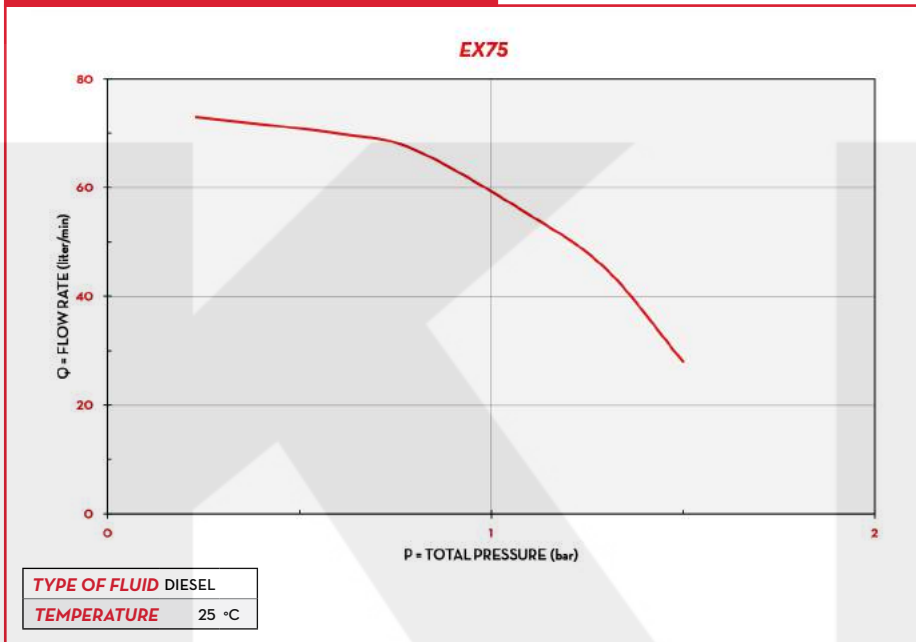

IN THE BOX

- EX75 PUMP
- FLANGED CONNECTIONS
- INSTRUCTION MANUAL

DETAILS



ON/OFF SWITCH



FLANGED CONNECTIONS

DIMENSIONS

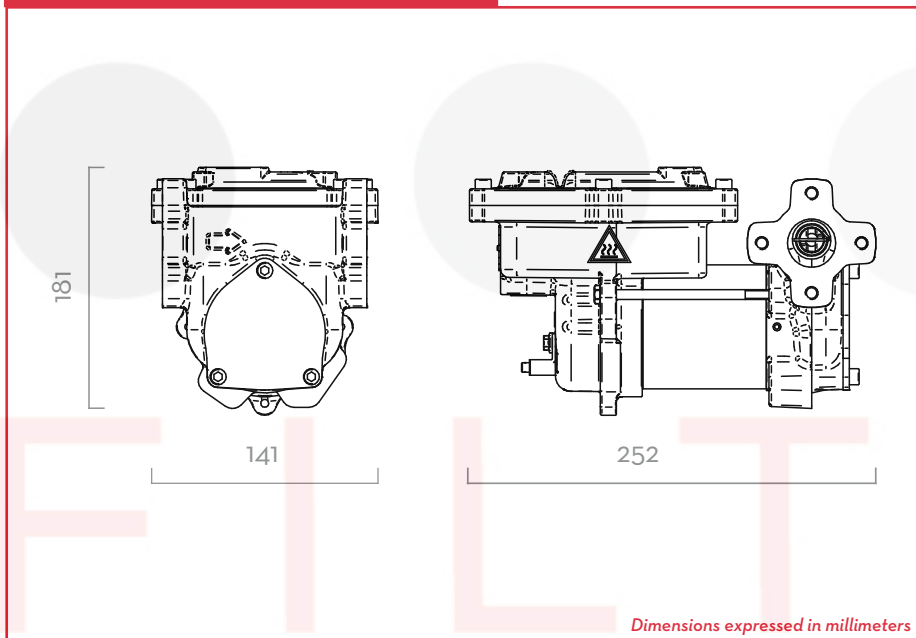

MATERIALS

- BODY: CAST IRON
- ROTOR: SINTERED STEEL
- VANES: PPS
- SEAL: VITON
- SHAFT: STEEL



PUMP

- > MAX 6M (20FT),
- > SUCTION HOSE Ø 1" MIN,
- > MAX SUCTION HEIGHT:
 - 2M (7FT) W/O NON RETURN VALVE
 - 4M (14FT) W NON RETURN VALVE



TANK

TECHNICAL DATA

CODE	DESCRIPTION	FLUIDS TYPE	FLOW-RATE		VOLTAGE			DUTY CICLE	RPM	INLET
			L/MIN	GPM	AC VOLT/HZ	POWER WATT	AMP. MAX.			
FO0380000	EX75 12V DC ATEX	D G K	75	19.8	12	240	20	1"	2700	1"

(*) UPON REQUEST IT IS AVAILABLE WITH DIFFERENT VOLTAGES AND 60 HZ FREQUENCY. THE PUMP CAN BE USED ONLY WITH THE FOLLOWING FLUIDS: DIESEL, KEROSENE, PETROL, PETROL ALCOHOL MIXED MAX 15%, AVGAS 100/100LL (PUMP ONLY), JET A/A1 (PUMP ONLY) - ASPEN 2/4

EX75



DISPENSERS



PUMPS



METERS



NOZZLE



FILTRATION



FLUID MONITORING

EX100 / EX140

FEATURES

- HIGH FLOW RATE
- HEAVY DUTY
- CONTINUOUS DUTY
- THERMAL PROTECTION
- UL VERSION AVAILABLE
- REMOVABLE PUMP FEET

The entirely new EX line is characterized by a high flow rate that works with a continuous duty cycle, and has been designed to be particularly suitable for Heavy Duty, i.e. for those demanding fleets that need to dispense fuels such as Gasoline, diesel or kerosene quickly.

PERFORMANCE

UP TO
140 L/MIN

FLOW RATE

AC
VOLTAGE

POWER



EX140

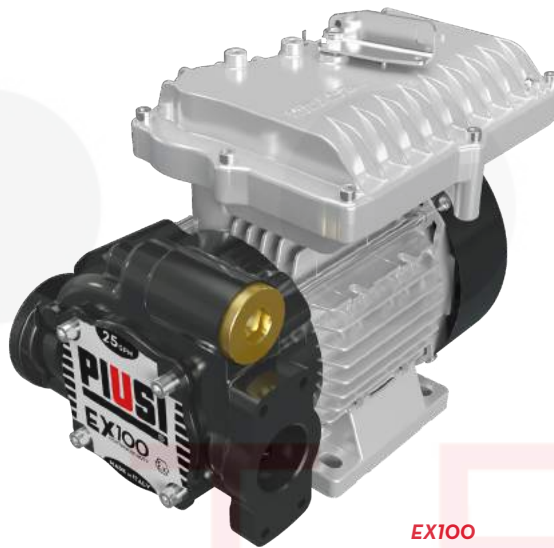

EX100



OUR PUMPS COMPLIES WITH THE FOLLOWING MARKING ATEX/IECEx

II	2	G	Ex	d	IIA	T4	Gb
GROUP	CATEGORY	TYPE OF EXPLOSIVE ATMOSPHERE	PERMANENT PREFIX	PROTECTION METHOD	GAS GLASS	TEMPERATURE CLASS	EQUIPMENT PROTECTION LEVEL

PACKAGING

CODE	WEIGHT		PACKAGING		
	KG	LBS	MM	INCH	PCS/BOX
FO0390010	25	55	240X400X350	9,4X15,7X13,8	1
FO0390020	25	55	240X400X350	9,4X15,7X13,8	1
FO0395010	25	55	240X400X350	9,4X15,7X13,8	1
FO0395020	25	55	240X400X350	9,4X15,7X13,8	1
FO0395030	25	55	240X400X350	9,4X15,7X13,8	1



HOSE REELS



ACCESSORIES



MERCHANDISE



AIR



ANTIFREEZE



AdBlue®



BIODIESEL



DIESEL



FOOD



GASOLINE



GREASE



KEROSENE



OIL



WATER



WINDSCREEN

CHART

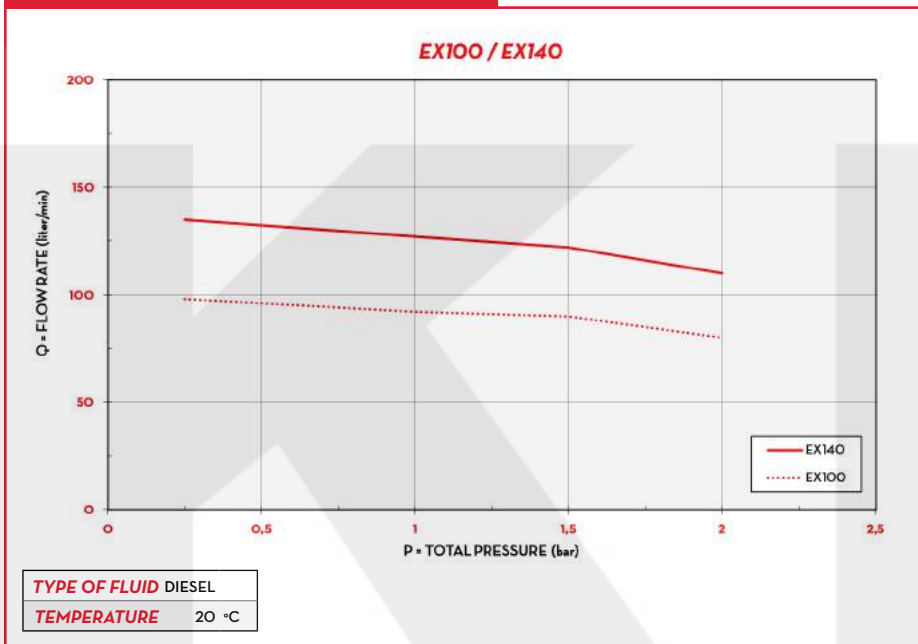

IN THE BOX

- EX100 / EX140 PUMP
- PUMP FEET
- INSTRUCTION MANUAL

DETAILS



VANE ROTOR



ON/OFF SWITCH

DIMENSIONS

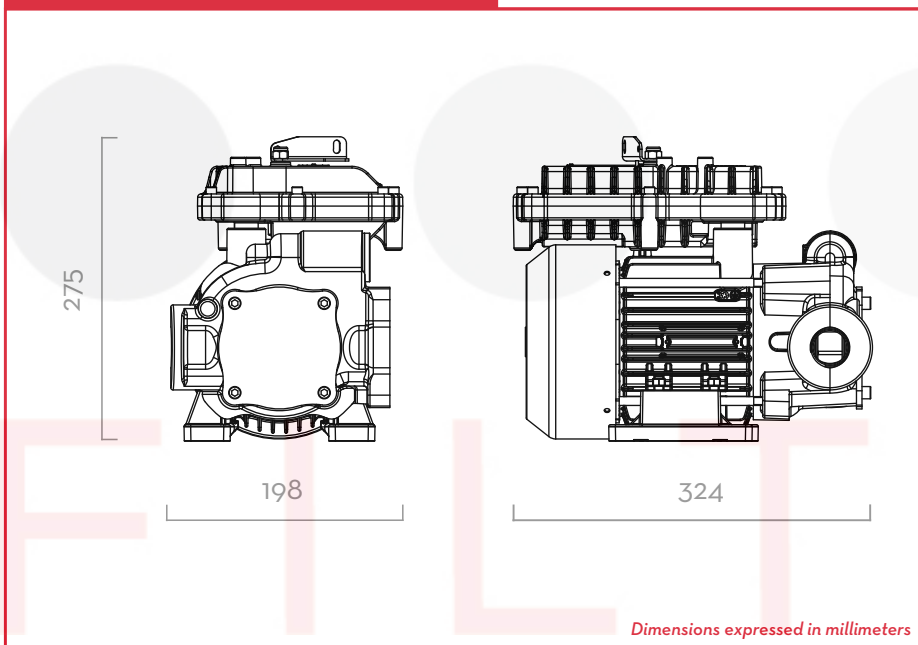

MATERIALS

- BODY: CAST IRON
- ROTOR: SINTERED STEEL
- VANES: TECHNOPYLIMER
- SEAL: VITON
- SHAFT: STEEL

TECHNICAL DATA

CODE	DESCRIPTION	FLUIDS TYPE	FLOW-RATE		VOLTAGE			DUTY CICLE	RPM	INLET		OUTLET	
			L/MIN	GPM	AC VOLT/HZ	POWER WATT	AMP. MAX.			CONTINUOUS	BSP	BSP	
FO0390010	EX 100 230/50	D G K	100	25	230/50	1035	4,5	YES	1450	1" 1/4	1"		
FO0390020	EX 100 230/60	D G K	100	25	230/60	874	3,8	YES	1750	1" 1/4	1"		
FO0395010	EX 140 230/50	D G K	140	37	230/50	1150	5	YES	1450	1" 1/4	1"		
FO0395020	EX 140 250/50	D G K	140	37	250/50	1125	4,5	YES	1450	1" 1/4	1"		
FO0395030	EX 140 230/60	D G K	140	37	230/60	920	4	YES	1750	1" 1/4	1"		

(*) UPON REQUEST IT IS AVAILABLE WITH DIFFERENT VOLTAGES AND 60 HZ FREQUENCY.
 COMPATIBLE FLUIDS: DIESEL, KEROSENE, PETROL, PETROL ALCOHOL MIXED MAX 15%, AVGAS 100/100LL, JET A/A1 - ASPEN 2/4

EX100 / EX140



DISPENSERS



PUMPS



METERS



NOZZLE



FILTRATION

FLUID
MONITORING

PANTHER AC

FEATURES

- COMPACT AND STURDY DESIGN
- READY TO USE
- EASY TO INSTALL
- INTEGRATED FILTER

The PIUSI PANTHER AC is a versatile self-priming rotary electric vane transfer pump available in three versions (56 - 72 - 90) particularly suitable for dispensers, fixed fuel transferring system and other industrial applications. It is equipped with a by-pass valve and an incorporated filter to stop impurities.

PERFORMANCE

UP TO

90 L/MIN

FLOW-RATE

AC**CONTINUOUS DUTY***

POWER

**PANTHER 56** (flanged not included)**PANTHER 72 - PANTHER 90** (flanged included)

PACKAGING

CODE	WEIGHT		PACKAGING			N. BOXES / EUROPALLET	
	KG	LBS	MM	INCH	PCS/BOX		
PANTHER 56							
FO0730000	7,4	16,3	345X175X255	-	1	60	84
OO0731000	7,4	16,3	345X175X255	-	1	60	84
OO0733000	7,4	16,3	345X175X255	-	1	60	84
PANTHER 72							
OO0732000	7,9	17,4	345X175X255	-	1	60	84
OO0735000	7,9	17,4	345X175X255	-	1	60	84
PANTHER 90							
FO0733020	8,2	19,9	345X175X255	-	1	60	84



HOSE REELS



ACCESSORIES



MERCHANDISE



AIR



ANTIFREEZE



AdBlue®



BIODIESEL



DIESEL



FOOD



GASOLINE



GREASE



KEROSENE



OIL



WATER



WINDSCREEN

CHART

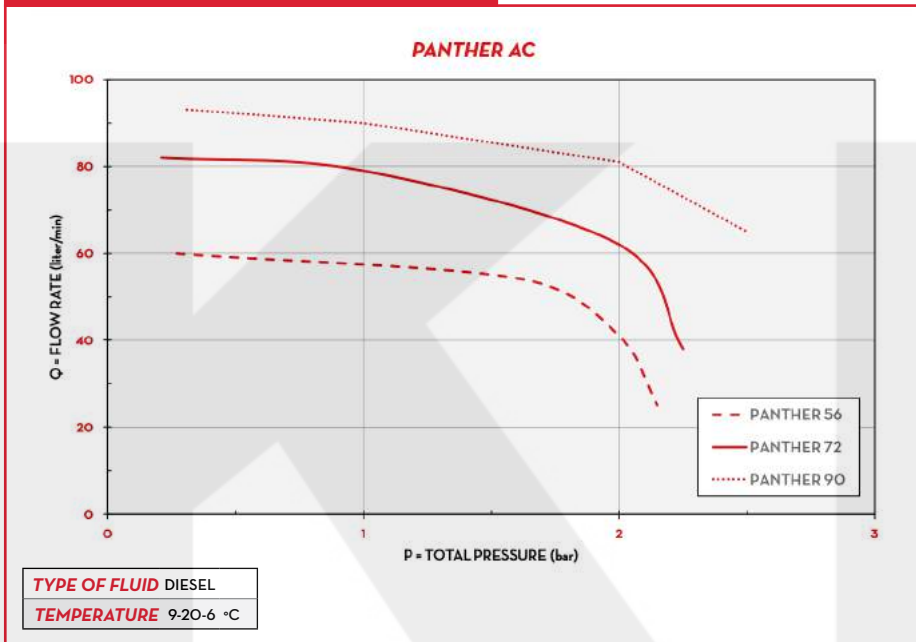

IN THE BOX

- PANTHER AC PUMP
- INSTRUCTION MANUAL

DETAILS



INTEGRATED FILTER



VANE ROTOR

DIMENSIONS

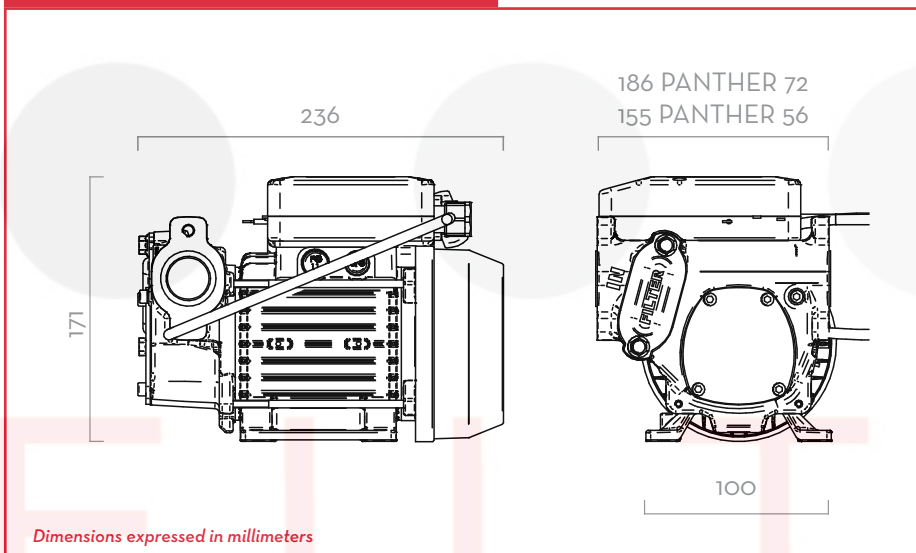

PUMP

- MAX 6M (20FT),
- SUCTION HOSE Ø 1" MIN,
- MAX SUCTION HEIGHT:
 - 2M (7FT) W/O NON RETURN VALVE
 - 4M (14FT) W NON RETURN VALVE



TANK

MATERIALS

- BODY: CAST IRON
- ROTOR: SINTERED STEEL
- VANES: TECHNOPOLYMER
- SHAFT: STEEL

TECHNICAL DATA

CODE	DESCRIPTION	FLUIDS TYPE	FLOW-RATE		VOLTAGE				RPM	INLET OUTLET BSP	FLANGE CONNECTION	BYPASS VALVE	INLET FILTER
			L/MIN	GPM	SINGLEPHASE MOTOR V/HZ	THREEPHASE MOTOR V/HZ	POWER WATT	AMP. MAX.					
PANTHER 56													
FO0730000	PANTHER 56 230/50	D	56	15	230/50	-	350	3	2900	1"	-	YES	YES
000731000	PANTHER 56 230/60	D	68	18	230/60	-	500	3,9	3400	1"	-	YES	YES
000733000	PANTHER 56 400/50	D	56	15	-	400/50	500	1,3	2900	1"	-	YES	YES
PANTHER 72													
000732000	PANTHER 72 230/50	D	72	19	230/50	-	500	4,2	2900	1"	YES	YES	YES
000735000	PANTHER 72 400/50	D	72	19	-	400/50	500	1,6	2900	1"	YES	YES	YES
PANTHER 90													
FO073302A	PANTHER 90 230/50	D	90	23,8	230/50	-	700	4,9	2900	1"	YES	YES	YES

UPON REQUEST IT IS AVAILABLE WITH DIFFERENT VOLTAGES AND 60 HZ FREQUENCY.
(*) EXCEPT PANTHER 90



DISPENSERS



PUMPS



METERS



NOZZLE



FILTRATION

FLUID
MONITORING

VISCOMAT VANE

FEATURES

- VERSATILITY
- MOBILE AND READY TO USE
- MULTIPURPOSE PUMP
- ADJUSTABLE BYPASS

The PIUSI VISCOMAT VANE is an electric vane pump suitable for all those applications where it is necessary to apply a transfer system with high suction capacity in order to transfer fluids with medium-high viscosity up to 500 cSt. The pump is fitted with an asynchronous and self-ventilating motor, closed and available in different voltages and frequencies in order to adapt to any working condition.

PERFORMANCE

UP TO

50 L/MIN

FLOW-RATE

AC**CONTINUOUS DUTY**

POWER

UP TO

500 CST

VISCOSITY



VISCOMAT VANE



PACKAGING

CODE	WEIGHT		PACKAGING			N. BOXES / EUROPALLET	
	KG	LBS	MM	INCH	PCS/BOX	✕	
VISCOMAT 70							
FO033490A	14,1	31,1	355X185X285	-	1	60	72
FO033190A	14,1	31,1	350X200X280	-	1	60	72
VISCOMAT 90							
FO0303M00	14,1	31,1	350X200X280	-	1	60	72
OO0303O00	14,1	31,1	350X200X280	-	1	60	72



HOSE REELS



ACCESSORIES



MERCHANDISE



AIR



ANTIFREEZE



AdBlue®



BIODIESEL



DIESEL



FOOD



GASOLINE



GREASE



KEROSENE



OIL



WATER



WINDSCREEN

CHART

VISCOMAT VANE

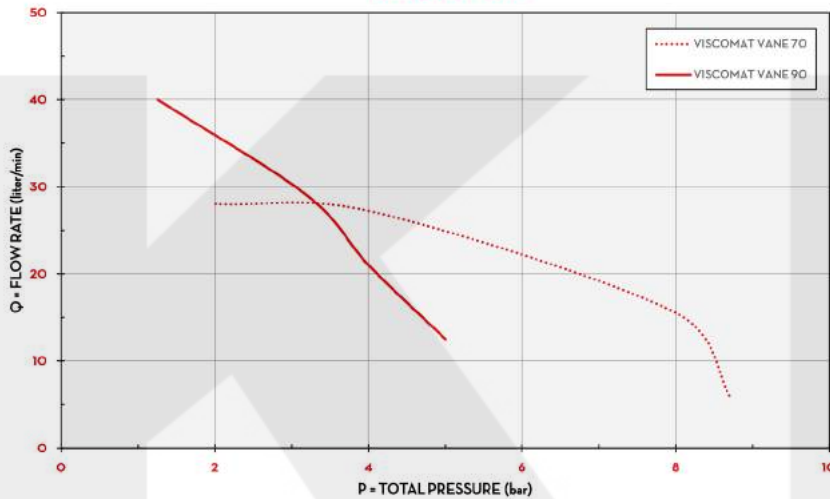

TYPE OF FLUID SAE 80W90
TEMPERATURE 17 °C

IN THE BOX

- VISCOMAT VANE PUMP
- INSTRUCTION MANUAL

DETAILS



ON/OFF SWITCH

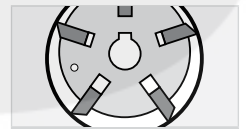

VANE ROTOR



ADJUSTABLE BYPASS VALVE

DIMENSIONS

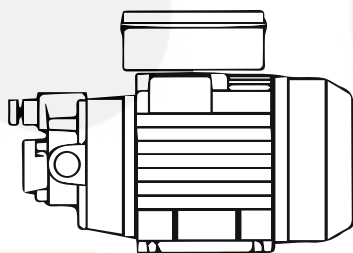

330

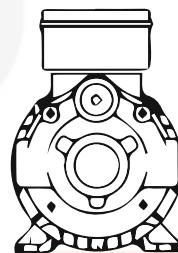

152

230

230

Dimensions expressed in millimeters

MATERIALS

- BODY: CAST IRON
- ROTOR: SINTERED STEEL
- VANES: TECHNOPYLIMER
- SHAFT: STEEL



PUMP



TANK

- SUCTION HOSE Ø 1" MIN,
- MAX SUCTION HEIGHT:
 - 2M (7FT) W/O NO BACK VALVE
 - 4M (14FT) W NO BACK VALVE

TECHNICAL DATA

CODE	DESCRIPTION	FLUIDS TYPE	FLOW-RATE		PRESSURE		VOLTAGE				RPM	INLET OUTLET		ADJUSTABLE BYPASS VALVE
			L/MIN	GPM	BAR	PSI	SINGLEPHASE MOTOR V/Hz	THREEPHASE MOTOR V/Hz	POWER WATT	AMP. MAX.		BSP		
VISCOMAT 70														
FO033490A	VISCOMAT 70 M 230/50-60	D O B	25	7	6	85	230/50-60	-	1200/1100	5,5 - 5,1	1470/1650	1"	YES	
FO033190A	VISCOMAT 70 T 400/50-60	D O B	25	7	6	85	-	400/50 - 400/60	650/1000	2,2 - 3,1	1450/1750	1"	YES	
VISCOMAT 90														
FO0303M00	VISCOMAT 70 M 230/50-60	D O B	50	13	5	71	230/50-60	-	1350/1600	6,2 - 4,9	1400/1600	1"	NO	
000303000	VISCOAMT 90 T 400/50	D O B	50	13	5	71	-	400/50	2000	5	1450	1"	YES	

UPON REQUEST IT IS AVAILABLE WITH DIFFERENT VOLTAGE AND FREQUENCY

VISCOMAT VANE



DISPENSERS



PUMPS



METERS



NOZZLE



FILTRATION

FLUID
MONITORING

E80 / E120

FEATURES

- VERSATILITY
- STURDY STRUCTURE
- LONG LASTING
- REASY TO USE
- THERMAL PROTECTION

The PIUSI E80 and E120 are self-priming rotary electric vane pumps, compact and easy to install, suitable to meet all those use requirements needing a high-performance and long lasting product. Its sturdy structure along with the thermal protection and the top-quality components allow its use at low working temperatures.

PERFORMANCE

UP TO

110 L/MIN

FLOW-RATE

AC**CONTINUOUS DUTY**

POWER

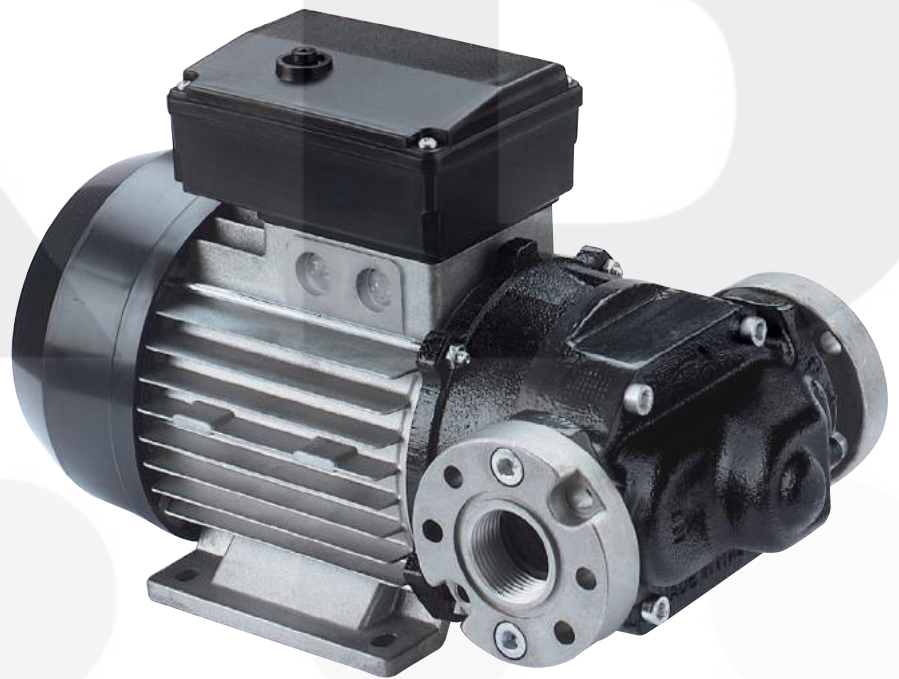

E80/E120



PACKAGING

CODE	WEIGHT		PACKAGING			N. BOXES / EUROPALLET	
	KG	LBS	MM	INCH	PCS/BOX	✕	
E 80							
000305000	13	28,7	355X185X285	-	1	60	72
000307000	13	28,7	355X185X285	-	1	60	72
E 120							
000326000	15,6	34,4	355X185X285	-	1	60	72
000312000	15,6	34,4	355X185X285	-	1	60	72



HOSE REELS



ACCESSORIES



MERCHANDISE



AIR



ANTIFREEZE



AdBlue®



BIODIESEL



DIESEL



FOOD



GASOLINE



GREASE



KEROSENE



OIL



WATER



WINDSCREEN

CHART

E80 - E120

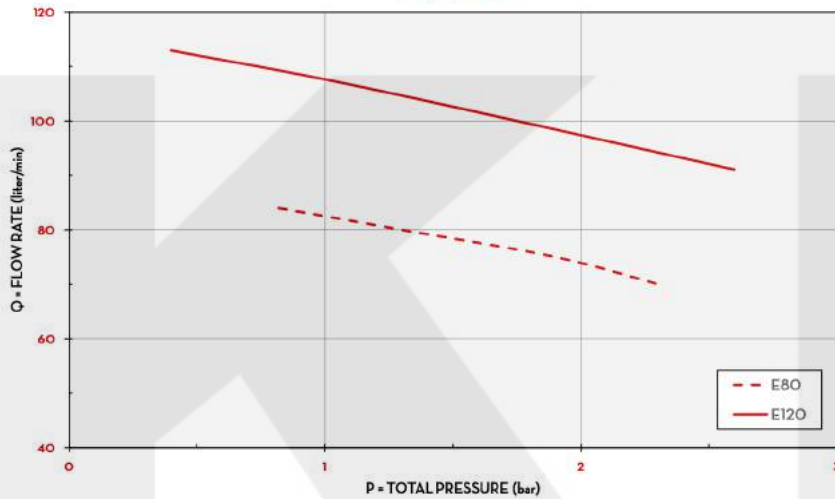

TYPE OF FLUID DIESEL

TEMPERATURE 15-13 °C

IN THE BOX

- E80/E120 PUMP
- FLANGED CONNECTION
- INSTRUCTION MANUAL

DETAILS



VANE ROTOR



FLANGED CONNECTION

DIMENSIONS

E80

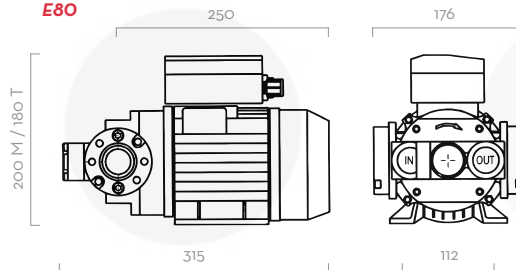

E120

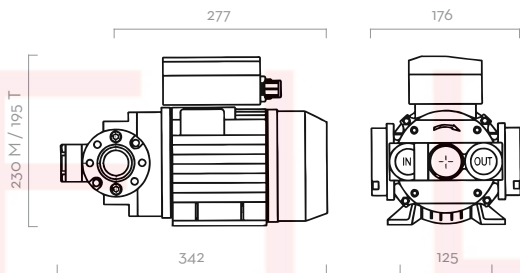

Dimensions expressed in millimeters

MATERIALS

- BODY: CAST IRON
- ROTOR: SINTERED STEEL
- VANES: ACETAL RESIN
- SEAL: VITON
- SHAFT: STEEL



PUMP



TANK

- > MAX 6M (20FT),
- > SUCTION HOSE Ø 1" MIN,
- > MAX SUCTION HEIGHT:
 - 2M (7FT) W/O NON RETURN VALVE
 - 4M (14FT) W NON RETURN VALVE

TECHNICAL DATA

CODE	DESCRIPTION	FLUIDS TYPE	FLOW-RATE		VOLTAGE				RPM	INLET OUTLET		FLANGE CONNECTION	BYPASS VALVE	INLET FILTER
			L/MIN	GPM	SINGLEPHASE MOTOR V/HZ	THREEPHASE MOTOR V/HZ	POWER WATT	AMP. MAX.		BSP				
E 80														
000305000	E 80 M	D	70	18	230/50	-	500	3,5	1400	1"	YES	YES	NO	
000307000	E 80 T	D	70	18	-	400/50	550	1,6	1450	1"	YES	YES	NO	
E 120														
000326000	E 120 M	D	100	26	230/50	-	750	5,7	1450	1"	YES	YES	NO	
000312000	E 120 T	D	100	26	-	400/50	750	2,2	1450	1"	YES	YES	NO	

E80 / E120



DISPENSERS



PUMPS



METERS



NOZZLE



FILTRATION



FLUID
MONITORING

E140

FEATURES

- CONTINUOUS DUTY
- HIGH FLOW-RATE
- HEAVY DUTY PUMP
- STURDY DESIGN

The E140 diesel transfer pump is versatile and suitable for different industries including automotive, agriculture, transportation, garages and construction. The E140 volumetric, self-priming vane pump for diesel transfer has a high seal and is reliable in conditions of use at low temperatures. With its solid and resistant body, the E140 is an easy to install diesel transfer pump, suitable for use in diesel dispensers and fixed fuel transfer systems, as well as other industrial applications. The compact cast iron structure makes the E140 electric pump the perfect system for performance and reliability.

PERFORMANCE

UP TO
140 L/MIN

FLOW RATE

AC
VOLTAGE

POWER



E140



PACKAGING

CODE	WEIGHT		PACKAGING			N. BOXES / EUROPALLET	
	KG	LBS	MM	INCH	PCS/BOX	✈	🚚
FO0395050	18	40	350X250X300	14X10X12	1	60	72



HOSE REELS



ACCESSORIES



MERCHANDISE



AIR



ANTIFREEZE



AdBlue®



BIODIESEL



DIESEL



FOOD



GASOLINE



GREASE



KEROSENE



OIL



WATER



WINDSCREEN

CHART

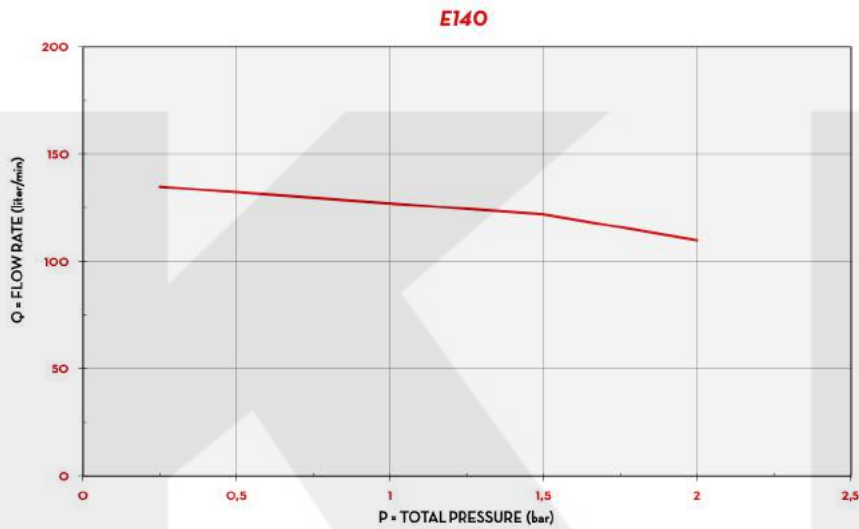

TYPE OF FLUID DIESEL

TEMPERATURE 20 °C

IN THE BOX

- E140 PUMP
- INSTRUCTION MANUAL

DETAILS



ON/OFF SWITCH



VANE ROTOR

DIMENSIONS

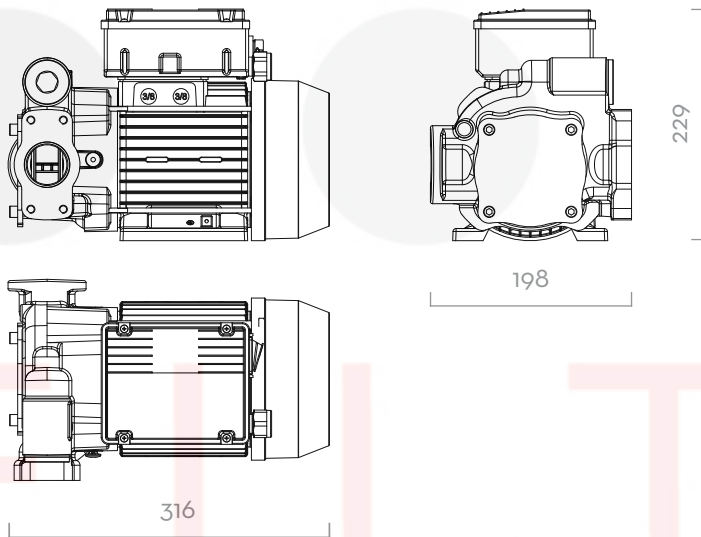

Dimensions expressed in millimeters

MATERIALS

- BODY: CAST IRON
- ROTOR: SINTERED STEEL
- VANES: TECHNOPYLIMER
- SEAL: VITON
- SHAFT: STEEL

TECHNICAL DATA

CODE	DESCRIPTION	FLUIDS TYPE	FLOW-RATE		VOLTAGE			DUTY CICLE	RPM	INLET
			L/MIN	GPM	AC VOLT/HZ	POWER WATT	AMP. MAX.			
FO0395050	E 140 230/50	D	140	37	230/50	1150	5	S1	1450	1" 1/4



DISPENSERS



PUMPS



METERS



NOZZLE



FILTRATION



FLUID
MONITORING

E300

FEATURES

- HIGH-FLOW PUMP
- STURDY STRUCTURE
- HEAVY DUTY APPLICATION
- IP44

The PIUSI E300 is an electric pump with open impeller suitable for all applications in which high-flows are required. Thus, it is the ideal equipment for topping up and transferring diesel from drums. It comes with an incorporated check valve in the suction port to prevent the siphon effect while ensuring automatic re-priming.

PERFORMANCE

UP TO

550 L/MIN

FLOW-RATE

AC

CONTINUOUS DUTY

POWER

1,8 BAR

MAX OPERATING
PRESSURE

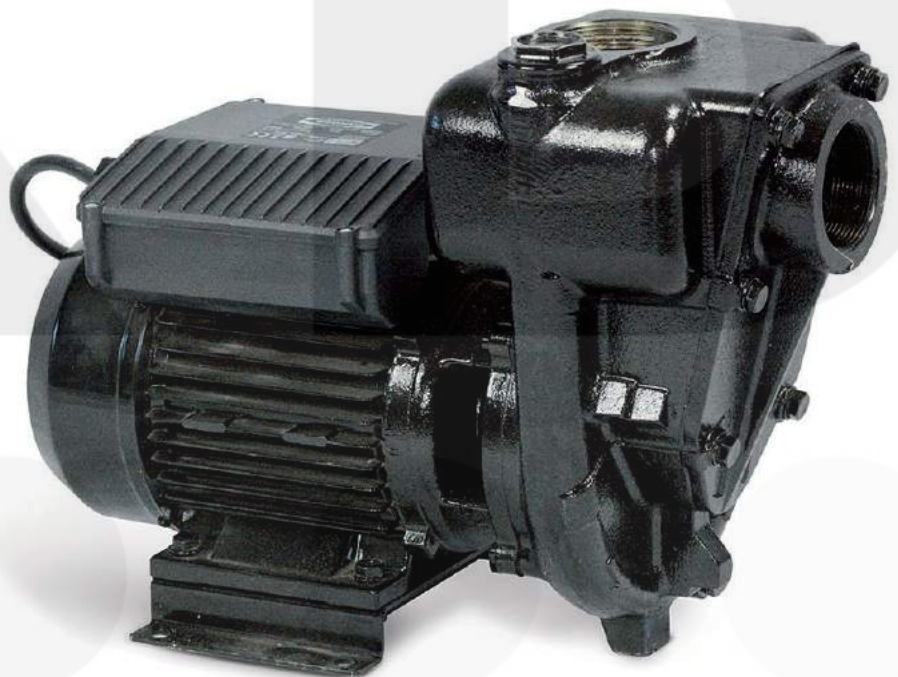

E300

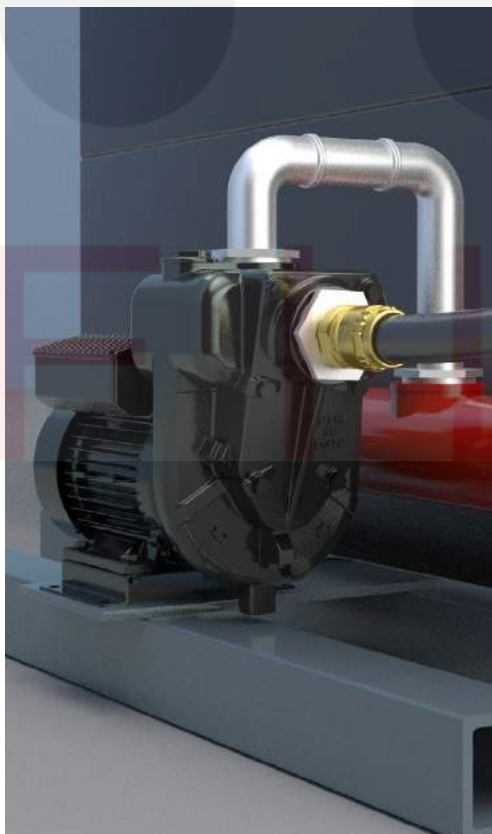

PACKAGING

CODE	WEIGHT		PACKAGING		
	KG	LBS	MM	INCH	PCS/BOX
E 300					
FO0321000	28	61,7	220X420X330	8,7X16,5X13	1



HOSE REELS



ACCESSORIES



MERCHANDISE



AIR



ANTIFREEZE



AdBlue®



BIODIESEL



DIESEL



FOOD



GASOLINE



GREASE



KEROSENE



OIL



WATER



WINDSCREEN

CHART



IN THE BOX

- E300 PUMP
- INSTRUCTION MANUAL

DETAILS



OPEN IMPELLER



2" IN/OUT CONNECTIONS



STEADY SUPPORT

DIMENSIONS

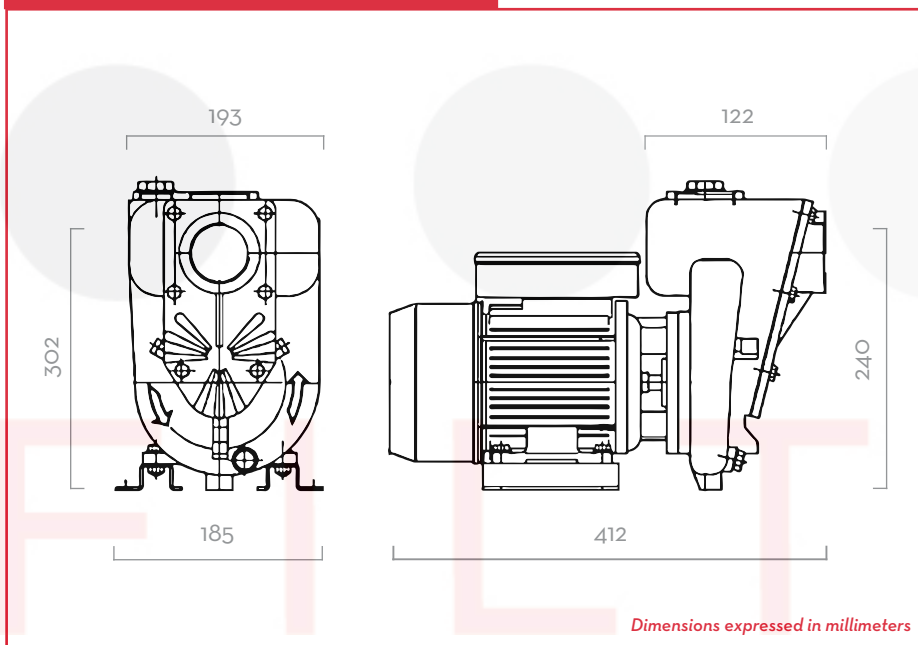

MATERIALS

- BODY: CAST IRON
- ROTOR: SINTERED STEEL
- VANES: ACETAL RESIN
- SEAL: VITON
- SHAFT: STEEL

TECHNICAL DATA

CODE	DESCRIPTION	FLUIDS TYPE	FLOW-RATE		VOLTAGE			RPM	INLET/OUTLET BSP
			L/MIN	GPM	AC VOLT/HZ	POWER WATT	AMP. MAX.		
E 300									
FO0321000	E 300	D	550	132	230/50	1500	9,2	2580	2"



DISPENSERS



PUMPS



METERS



NOZZLE



FILTRATION



FLUID
MONITORING

BP3000

FEATURES

- VERSATILE
- ON BOARD APPLICATION
- EMC COMPATIBILITY
- VIBRATION RESISTANT
- IP55

The PIUSI BP3000 is a long-lasting, self-priming vane pump. Powerful, versatile and compact, it is equipped with a built-in by-pass valve. Available in both 12V and 24V versions, it represents the core of the Piusi range of pumps for on-board applications, particularly in the off-road and earthmoving machinery industry.

PERFORMANCE

UP TO
50 L/MIN

FLOW-RATE

AC/DC

VOLTAGE
POWER

30 MIN

DUTY CICLE

UP TO
4MT

SELF-PRIMING

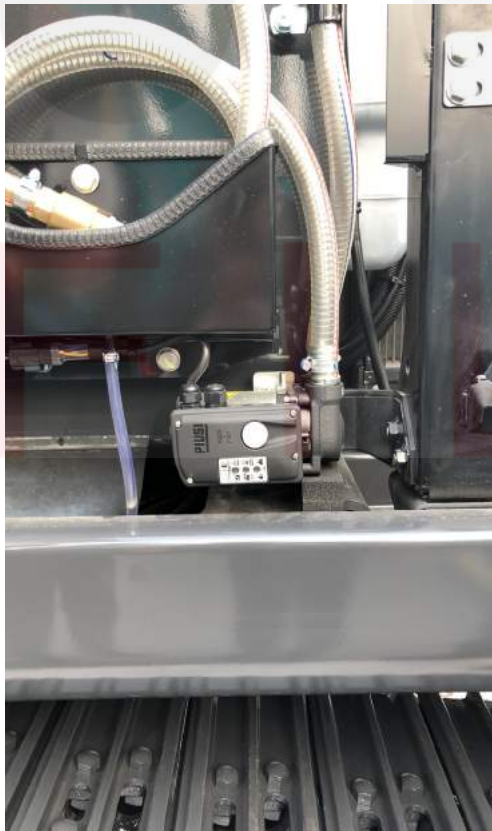

BP3000 INLINE (threaded ports)



BP3000 (ports not threaded)

PACKAGING

CODE	WEIGHT		PACKAGING		
	KG	LBS	MM	INCH	PCS/BOX
FO0342000	3,5	7,9	200X120X140	7,9X4,7X5,5	1
FO0347000	3,5	7,9	200X120X140	7,9X4,7X5,5	1
FO0357000	3,5	7,9	200X120X140	7,9X4,7X5,5	1
FO0357500	3,5	7,9	200X120X140	7,9X4,7X5,5	1
FO0358000	3,5	7,9	200X120X140	7,9X4,7X5,5	1
FO0358500	3,5	7,9	200X120X140	7,9X4,7X5,5	1



HOSE REELS



ACCESSORIES



MERCHANDISE



AIR



ANTIFREEZE



AdBlue®



BIODIESEL



DIESEL



FOOD



GASOLINE



GREASE



KEROSENE



OIL



WATER



WINDSCREEN

CHART

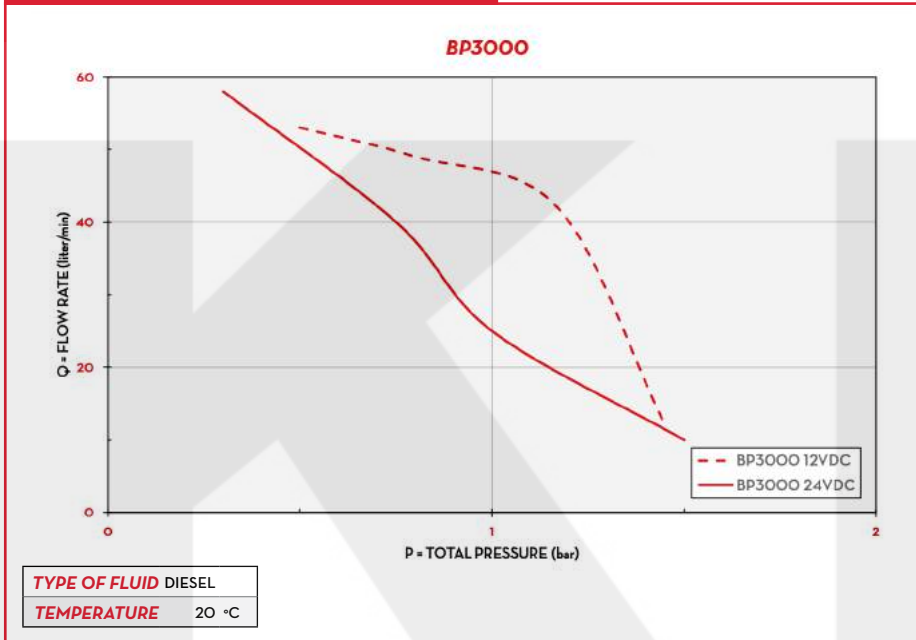

IN THE BOX

- BP3000 PUMP
- INSTRUCTION MANUAL

DETAILS



VANE ROTOR



IN-LINE VERSION AVAILABLE



CONNECTION KIT (pag. 86)

DIMENSIONS

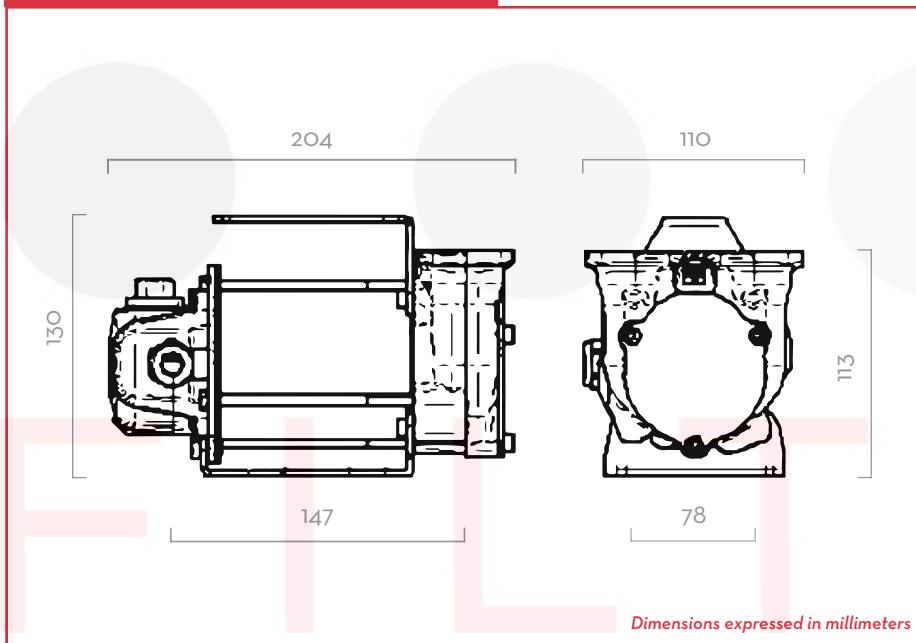

MATERIALS

- BODY: CAST IRON
- ROTOR: SINTERED STEEL
- VANES: ACETAL RESIN
- SEAL: NBR
- SHAFT: STEEL



PUMP



TANK

- > MAX 6M (20FT),
- > SUCTION HOSE Ø 1" MIN,
- > MAX SUCTION HEIGHT:
 - 2M (7FT) W/O NON RETURN VALVE
 - 4M (14FT) W NON RETURN VALVE

TECHNICAL DATA

CODE	DESCRIPTION	FLUIDS TYPE	FLOW-RATE		VOLTAGE			DUTY CICLE	RPM	THREADED PORTS BSP	MAX WORKING PRESSURE BAR
			L/MIN	GPM	DC VOLT	POWER WATT	AMP. MAX.	MINUTES			
FO0342000	BP3000 12V	D	50	13	12	300	24	30	2900	-	1,5
FO0347000	BP3000 24V / 12V	D	50 / 30	13 / 6	24/12	310 / 80	13 / 6,5	30	2900 / 1500	-	1,5
FO0357000	BP3000 12V HORIZONTAL	D	50	13	12	300	24	30	2900	-	1,5
FO0357500	BP3000 INLINE 12V	D	50	13	12	300	24	30	2900	3/4"	1,5
FO0358000	BP3000 24V HORIZONTAL	D	50 / 30	13 / 6	24/12	310 / 80	13 / 6,5	30	2900 / 1500	-	1,5
FO0358500	BP3000 INLINE 24V / 12V	D	50 / 30	13 / 6	24/12	310 / 80	13 / 6,5	30	2900 / 1500	3/4"	1,5



DISPENSERS



PUMPS



METERS



NOZZLE



FILTRATION



FLUID MONITORING

CARRY

FEATURES

- EASY TO INSTALL
- SAFE TO MOVE
- LONG LASTING APPLICATION

The PIUSI CARRY 3000 pump is a diesel transfer DC pump designed to meet the needs of those who are looking for a long-lasting, high quality and portable pump. CARRY 3000 is equipped with a sturdy handle to allow easy carriage and comes complete with dispensing pipe, power cables and the dispensing nozzle.

PERFORMANCE

UP TO
70 L/MIN

FLOW-RATE

12/24V

VOLTAGE
POWER

30 MIN

DUTY CICLE



CARRY PANTHER

CARRY



CARRY 3000 INLINE

PACKAGING

CODE	WEIGHT		PACKAGING			N. BOXES / EUROPALET	
	KG	LBS	MM	INCH	PCS/BOX	✕	
FO022300C	4,2	9,3	260X235X164	-	1	84	120
FO022400C	4,2	9,3	260X235X164	-	1	84	120
FO022326O	4,2	9,3	260X235X164	-	1	84	120
FO022424O	4,2	9,3	260X235X164	-	1	84	120
FO034004B	4,2	9,3	260X235X164	-	1	84	120
FO034104C	4,2	9,3	260X235X164	-	1	84	120



HOSE REELS



ACCESSORIES



MERCHANDISE



AIR



ANTIFREEZE



AdBlue®



BIODIESEL



DIESEL



FOOD



GASOLINE



GREASE



KEROSENE



OIL



WATER



WINDSCREEN

CHART

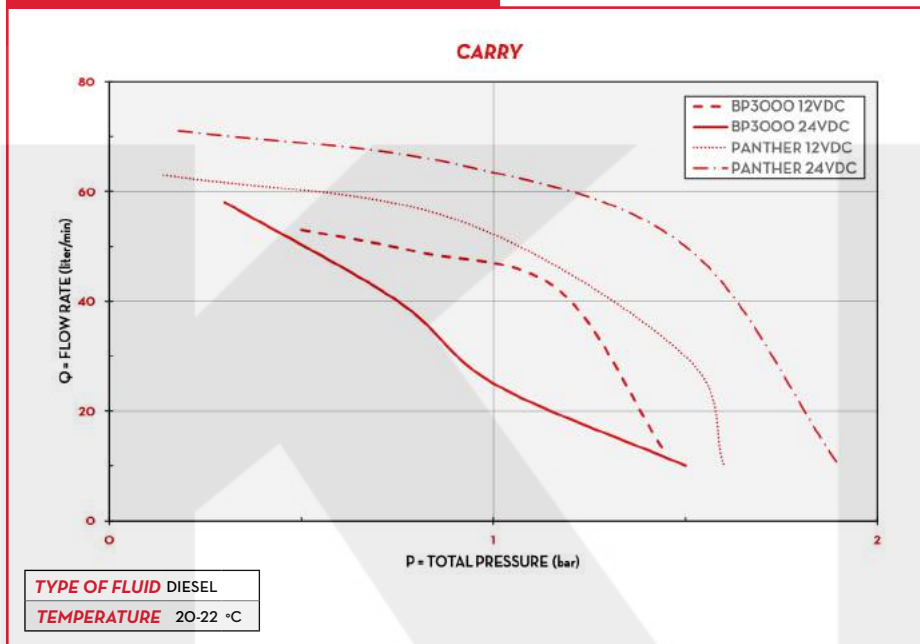

IN THE BOX

- CARRY PUMP
- HANDLE
- DISPENSING PIPE
- ELECTRIC CABLE WITH CLAMPS
- CONNECTIONS

DETAILS



STURDY HANDLE



ELECTRIC CABLE

DIMENSIONS

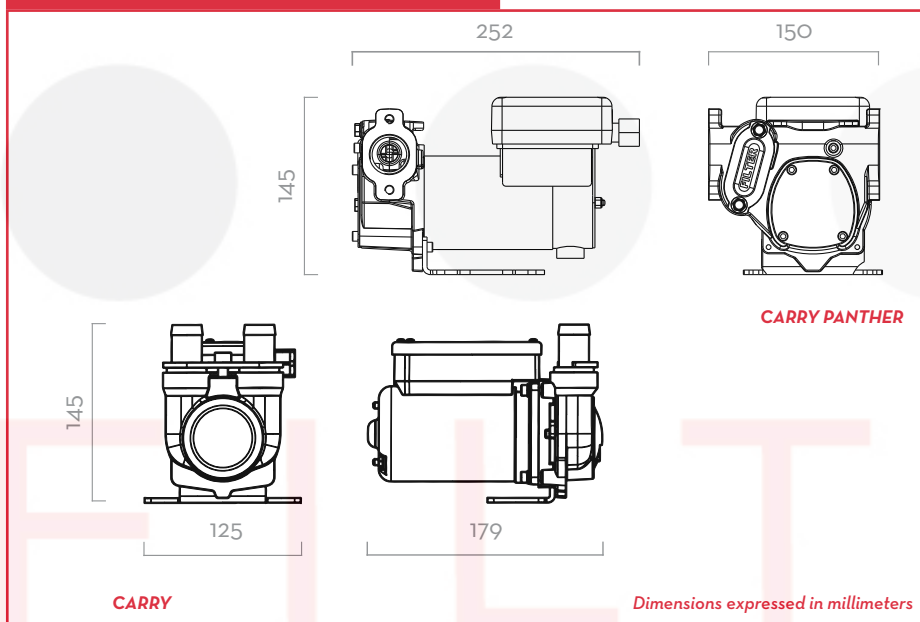

MATERIALS

- BODY: CAST IRON
- ROTOR: SINTERED STEEL
- VANES: ACETAL RESIN
- SEAL: NBR
- SHAFT: STEEL

TECHNICAL DATA

CODE	DESCRIPTION	FLUIDS TYPE	FLOW-RATE		VOLTAGE			FUSE	DUTY CICLE	RPM	PRESSURE MAX	ON/OFF SWITCH	INLET/OUTLET
			L/MIN	GPM	DC VOLT	POWER WATT	AMP. MAX.						
FO022300C	CARRY 3000 12V	D	50	13	12	300	24	25	30	2900	1,5	YES	-
FO022400C	CARRY 3000 24V / 12V	D	50/30	13/6	24/12	310/80	13/6,5	15	30	2900/1500	1,5	YES	-
FO0223260	CARRY 3000 INLINE 12V	D	50	13	12	300	24	25	30	2900	1,5	YES	3/4"
FO0224240	CARRY 3000 INLINE 24V	D	50/30	13/6	24/12	310/80	24	15	30	2900/1500	1,5	YES	3/4"
FO034004B	CARRY PANTHER 12V	D	56	15	12	420	13/6,5	-	30	2900	-	YES	1"
FO034104C	CARRY PANTHER 12V / 24V	D	35/70	9/18	24/12	600/200	13/6,5	-	30	3500/1800	-	YES	1"



DISPENSERS



PUMPS



METERS



NOZZLE



FILTRATION



FLUID
MONITORING

PANTHER DC

FEATURES

- STURDY STRUCTURE
- EASY TO INSTALL
- COMPACT DESIGN
- IP55

The PANTHER DC is a rotary, self-priming vane pump suitable for all applications in which important flow rates are required. This equipment is fitted with an incorporated filter (100µ) and by-pass valve. The 24/12 V version can be used with both voltages.

PERFORMANCE

UP TO

70 L/MIN

FLOW-RATE

12/24V

VOLTAGE

POWER

30 MIN

DUTY CICLE



PANTHER DC



PACKAGING

CODE	WEIGHT		PACKAGING		
	KG	LBS	MM	INCH	PCS/BOX
FO034000B	7,5	16,5	345X175X255	13,6X6,9X10	1
FO034001B	7,5	16,5	345X175X255	13,6X6,9X10	1
FO034100C	7,5	16,5	345X175X255	13,6X6,9X10	1
FO034101C	7,5	16,5	345X175X255	13,6X6,9X10	1
FO034116C	7,5	16,5	345X175X255	13,6X6,9X10	1



HOSE REELS



ACCESSORIES



MERCHANDISE



AIR



ANTIFREEZE



AdBlue®



BIODIESEL



DIESEL



FOOD



GASOLINE



GREASE



KEROSENE



OIL



WATER



WINDSCREEN

CHART

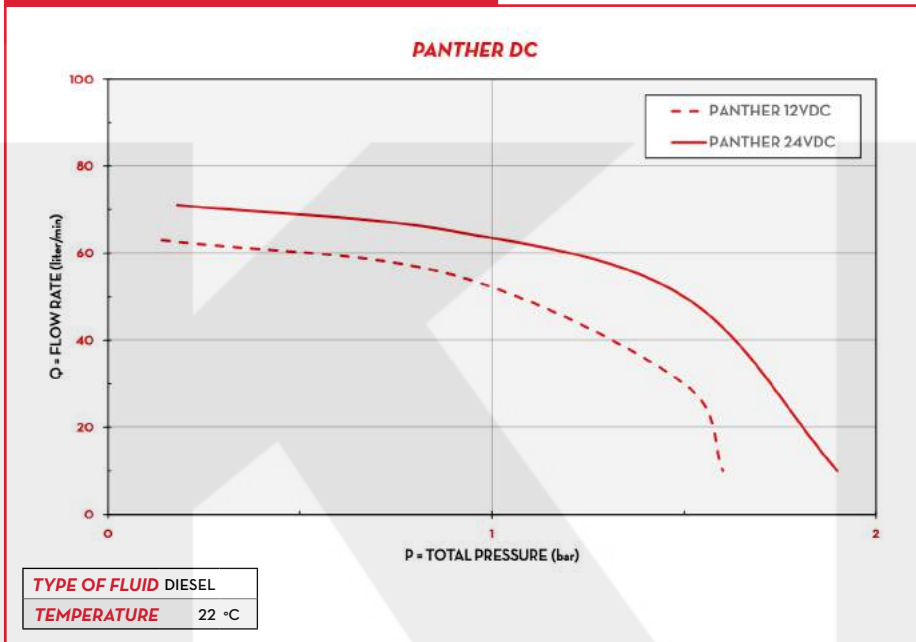

IN THE BOX

- PANTHER DC PUMP
- INSTRUCTION MANUAL

DETAILS



ON/OFF SWITCH



1" BSP THREADED



INTEGRATED FILTER

DIMENSIONS

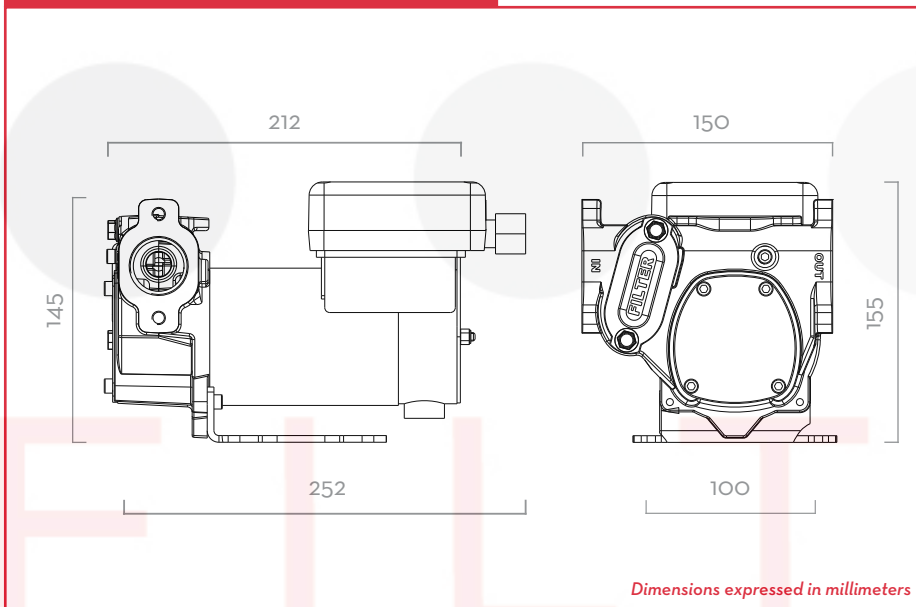

MATERIALS

- BODY: CAST IRON
- ROTOR: SINTERED STEEL
- VANES: ACETAL RESIN
- MOTOR: ALUMINIUM CASING



PUMP



TANK

- MAX 6M (20FT),
- SUCTION HOSE Ø 1" MIN,
- MAX SUCTION HEIGHT:
 - 2M (7FT) W/O NON RETURN VALVE
 - 4M (14FT) W NON RETURN VALVE

TECHNICAL DATA

CODE	DESCRIPTION	FLUIDS TYPE	FLOW-RATE		VOLTAGE			DUTY CICLE	RPM	INLET
			L/MIN	GPM	DC VOLT	POWER WATT	AMP. MAX.	MINUTES		BSP
FO034000B	PANTHER DC 12V	D	56	14,8	12	300	35	30	2900	1"
FO034001B	PANTHER DC 12V W/CABLE 2M W/PLIERS	D	56	14,8	12	300	35	30	2900	1"
FO034100C	PANTHER DC 24/12V	D	70 / 35	18,5 / 9,2	24/12	420 / 150	25 / 16	30	3600 / 1800	1"
FO034101C	PANTHER DC 24/12V W/CABLE 2M	D	70 / 35	18,5 / 9,2	24/12	420 / 150	25 / 16	30	3600 / 1800	1"
FO034116C	PANTHER DC 24/12V W/CABLE 4M W/PLIERS	D	70 / 35	18,5 / 9,2	24/12	420 / 150	25 / 16	30	3600 / 1800	1"



DISPENSERS



PUMPS



METERS



NOZZLE



FILTRATION



FLUID
MONITORING

BIPUMP

FEATURES

- STURDY STRUCTURE
- COMPACT DESIGN
- HEAVY DUTY
- HIGH RELIABILITY
- IP55

The PIUSI BIPUMP is a diesel transfer pump, available both in 12 and 24 V versions, designed to meet the needs of those who are looking for a long-lasting quality, high flow-rate pump, applicable to different industries. It is easy to install and is suitable for being applied on diesel dispensers and fixed fuel transfer systems, as well as other applications.

PERFORMANCE

UP TO

85 L/MIN

FLOW-RATE

12/24V

VOLTAGE

POWER

30 MIN

DUTY CICLE



BIPUMP

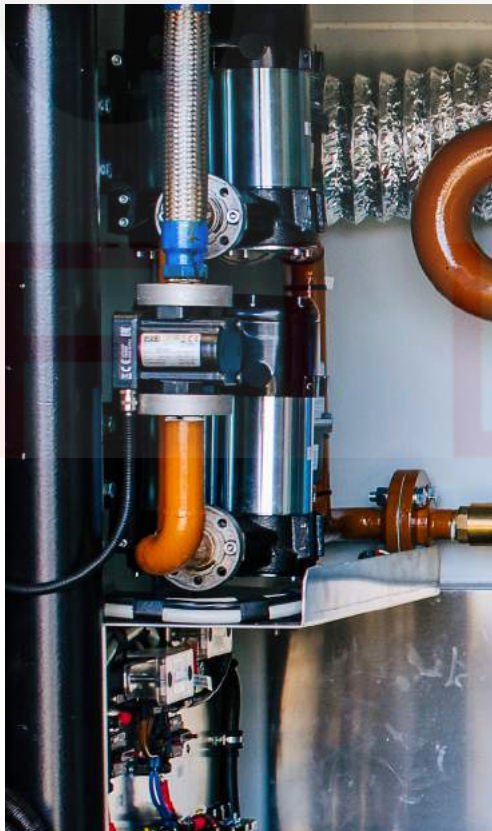

PACKAGING

CODE	WEIGHT		PACKAGING			N. BOXES / EUROPALLET	
	KG	LBS	MM	INCH	PCS/BOX	✕	
FO0363A0A	9,9	21,8	345X175X255	-	1	60	72
FO0363B0A	9,9	21,8	345X175X255	-	1	60	72
FO0363O1A	9,9	21,8	345X175X255	-	1	60	72
FO0363O2A	9,9	21,8	345X175X255	-	1	60	72
FO0363O3A	9,9	21,8	345X175X255	-	1	60	72
FO0363O4A	9,9	21,8	345X175X255	-	1	60	72
FO036321A	9,9	21,8	345X175X255	-	1	60	72
FO0363380	9,9	21,8	345X175X255	-	1	60	72



HOSE REELS



ACCESSORIES



MERCHANDISE



AIR



ANTIFREEZE



AdBlue®



BIODIESEL



DIESEL



FOOD



GASOLINE



GREASE



KEROSENE



OIL



WATER



WINDSCREEN

CHART

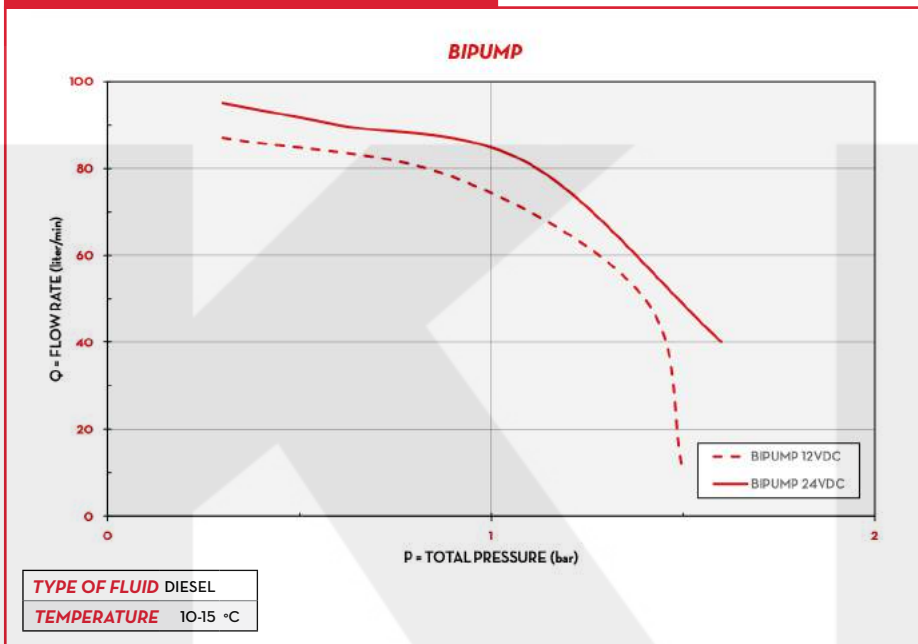

IN THE BOX

- BIPUMP UNIT
- FLANGED CONNECTIONS
- INSTRUCTION MANUAL

DETAILS

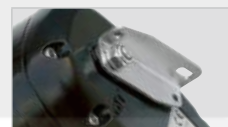

ON/OFF SWITCH



FLANGED CONNECTIONS

DIMENSIONS

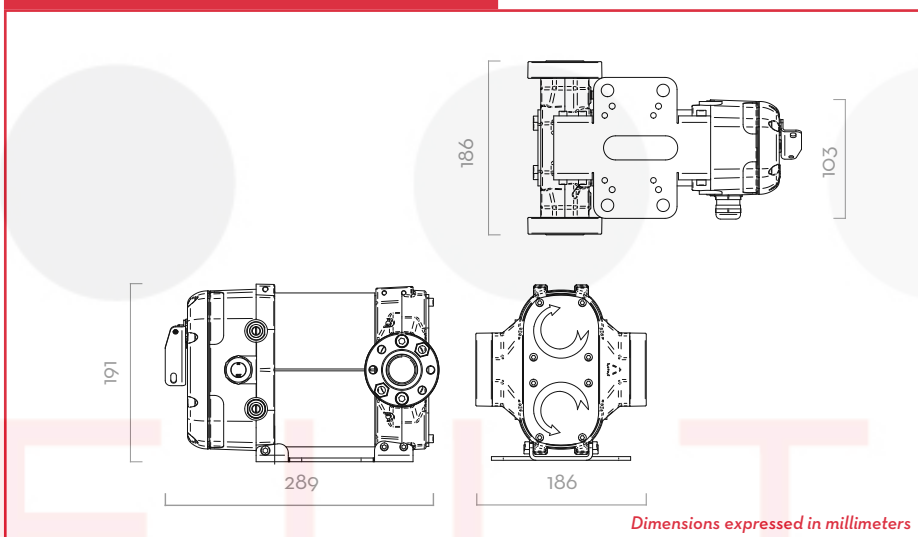

PUMP

- > MAX 6M (20FT),
- > SUCTION HOSE Ø 1" MIN,
- > MAX SUCTION HEIGHT:
- 2M (7FT) W/O NON RETURN VALVE
- 4M (14FT) W NON RETURN VALVE



TANK

MATERIALS

- BODY: CAST IRON
- ROTOR: SINTERED STEEL
- VANES: ACETAL RESIN
- SEAL: NBR
- SHAFT: STEEL

TECHNICAL DATA

CODE	DESCRIPTION	FLUIDS TYPE	FLOW-RATE		VOLTAGE			DUTY CICLE		RPM	INLET BSP
			L/MIN	GPM	DC VOLT	POWER WATT	AMP. MAX.	MINUTES			
FOO363A0A	BIPUMP 12V WITH ON/OFF SWITCH	D	85	22,4	12	500	42	30	2000	1"	
FOO363B0A	BIPUMP 24V WITH ON/OFF SWITCH	D	85	22,4	24	500	21	30	2000	1"	
FOO36301A	BIPUMP 12V WITH CABLE 2M	D	85	22,4	12	500	42	30	2000	1"	
FOO36302A	BIPUMP 12V WITH CABLE 4M	D	85	22,4	12	500	42	30	2000	1"	
FOO36303A	BIPUMP 24V WITH CABLE 2M	D	85	22,4	24	500	21	30	2000	1"	
FOO36304A	BIPUMP 24V WITH CABLE 4M	D	85	22,4	24	500	21	30	2000	1"	
FOO36321A	BIPUMP 12/24 WITHOUT ON/OFF SWITCH	D	85	22,4	12/24	500/500	42/21	30/30	2000	1"	
FOO363380	BI-PUMP 12V W/SWITCH W/CABLE 6M	D	85	22,4	12	500	42	30	2000	1"	



DISPENSERS



PUMPS



METERS



NOZZLE



FILTRATION



FLUID
MONITORING

PIUSI HAND PUMP

FEATURES

- OPTIMIZED SUCTION CAPACITY
- STURDY CONNECTOR
- HEAVY DUTY LEVER
- FLUENT REVOLUTION
- HIGH EFFICIENCY
- ADJUSTABLE SUCTION PIPE

The PIUSI HAND PUMP is a rotary vane pump suitable for transferring low viscosity oils and diesel. Entirely designed, manufactured and certified in Italy, this sturdy pump guarantees a professional performance and easy transfer.

PERFORMANCE

UP TO

38L

PER 100 REV

FLOW-RATE

3MT

LENGTH

DELIVERY HOSE



PIUSI HAND PUMP WITH HOSE AND STAINLESS STEEL SPOUT

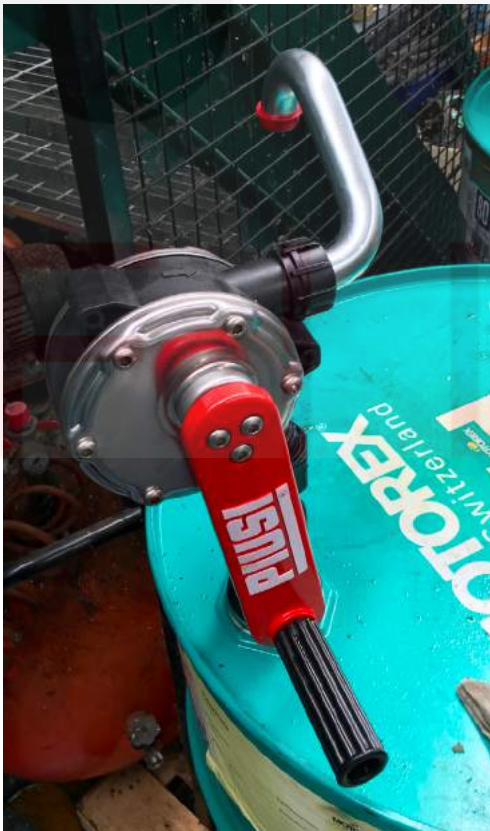

PACKAGING

CODE	WEIGHT		PACKAGING			N. BOXES / EUROPALLET	
	KG	LBS	MM	INCH	PCS/BOX	✈	🚚
WITHOUT HOSE							
FO033250A	2,1	4,6	350X170X140	-	1	50	100
WITH HOSE							
FO033252A	3,2	7	300X300X180	-	1	50	100



HOSE REELS



ACCESSORIES



MERCHANDISE



AIR



ANTIFREEZE



AdBlue®



BIODIESEL



DIESEL



FOOD



GASOLINE



GREASE



KEROSENE



OIL



WATER



WINDSCREEN

CHART

PIUSI HAND PUMP

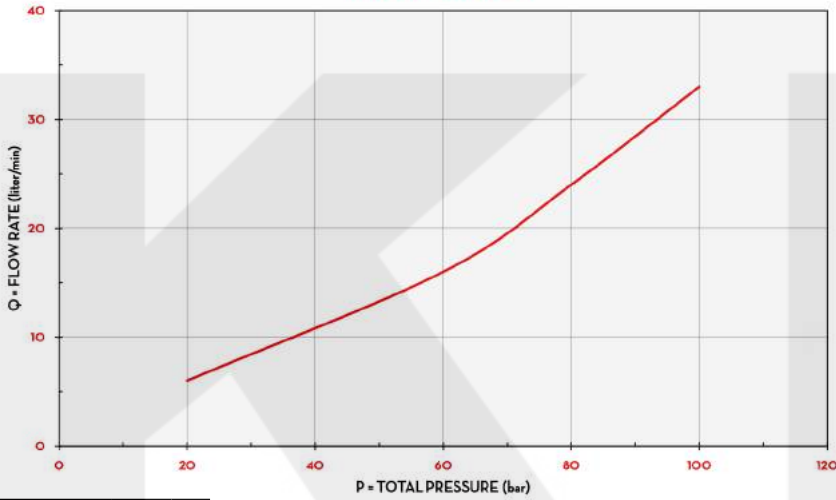

TYPE OF FLUID SAE 10W40
 TEMPERATURE 23 °C

IN THE BOX

- PISUI HAND PUMP
- SPOUT
- SUCTION PIPE
- DRUM CONNECTOR
- INSTRUCTION MANUAL

DETAILS



2" BSP DRUM CONNECTOR



SUCTION PIPE



NON-SLIP HANDLE



STAINLESS STEEL SPOUT

DIMENSIONS

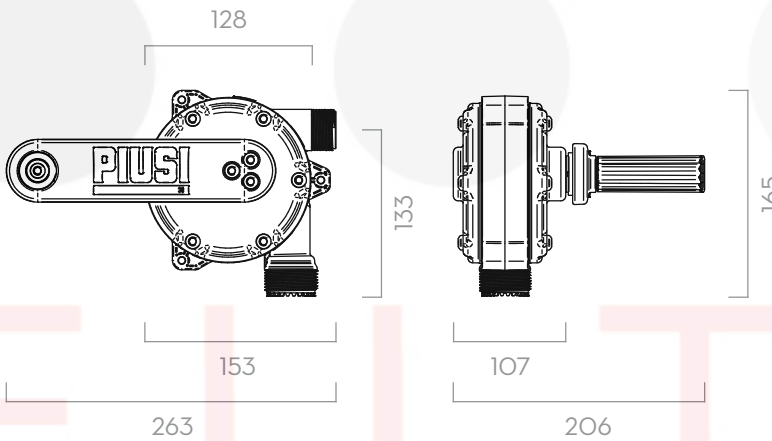

Dimensions expressed in millimeters

MATERIALS

- BODY: STAINLESS STEEL,
- TECHNOPOLYMER
- ROTOR: TECHNOPOLYMER
- VANES: TECHNOPOLYMER

TECHNICAL DATA

CODE	DESCRIPTION	FLUIDS TYPE	CAPACITY PER 100 REVOLUTIONS		DRUM CONNECTOR	SUCTION TUBE	"S" SPOUT AND HOSE TAIL	DELIVERY HOSE LENGTH
			L	USG				
WITHOUT HOSE								
FO033250A	PIUSI HAND PUMP 2" BSP	D O	38	10	2" BSP	YES	YES	-
WITH HOSE								
FO033252A	KIT PIUSI HAND PUMP 2" BSP WITH HOSE	D O	38	10	2" BSP	YES	-	3M

PIUSI HAND PUMP



DISPENSERS



PUMPS



METERS



NOZZLE



FILTRATION



FLUID
MONITORING

HAND PUMPS

FEATURES

- STURDY CONNECTOR
- SUCTION PIPE INCLUDED
- MULTI-PURPOSE PUMPS

Besides the top-quality Hand Pump, PIUSI offers a range of HAND PUMPS with different characteristics - piston or rotary - and fittings to transfer fluids from drums.

PERFORMANCE

UP TO
90L
PER 100 REV
FLOW-RATE

UP TO
1100MM
LENGTH
SUCTION HOSE



PM GPI PISTON



PACKAGING

CODE	WEIGHT		PACKAGING			N. BOXES / EUROPALLET	
	KG	LBS	MM	INCH	PCS/BOX	✕	
HAND PUMPS							
FO031600A	5,3	11,7	465X395X240	-	1	30	40
FO033200B	5,6	12,3	340X160X125	-	1	120	144
FO033201B	5,3	11,7	465X395X240	-	1	120	144
FO034900A	3,0	6,6	600X110X65	-	1	160	240
FO035100A	3,0	6,6	300X150X105	-	1	160	200



HOSE REELS



ACCESSORIES



MERCHANDISE



AIR



ANTIFREEZE



AdBlue®



BIODIESEL



DIESEL



FOOD



GASOLINE



GREASE



KEROSENE



OIL



WATER



WINDSCREEN

IN THE BOX

- ROTARY/PISTON PUMP
- SUCTION TUBE
- CONNECTOR/ADAPTOR
- SPOUT/DELIVERY HOSE
- INSTRUCTION MANUAL

DETAILS

NON-SLIP HANDLE

MATERIALS

- BODY: IRON/STAINLESS STEEL/ALUMINIUM



PISTON HAND PUMP



CAST IRON ROTATIVE



ALUMINIUM ROTATIVE



PISTON HAND PUMP

TECHNICAL DATA

CODE	DESCRIPTION	FLUIDS TYPE	CAPACITY	INLET / OUTLET	SUCTION HOSE LENGTH MM	CARTRIDGE Ø MM	SIZE CARTRIDGE OZ
			L / 100REV				
HAND PUMPS							
FOO31600A	PM GPI PISTON		90	1-3/4" NPT	1100	-	-
FOO33200B	ALUMINIUM ROTATIVE HAND PUMP		27	M32 X 1,5 - M25 X 1,5	960	-	-
FOO33201B	CAST IRON ROTATIVE HAND PUMP		25	M32 X 1,5 - M25 X 1,5	960	-	-
FOO34900A	PISTON HAND PUMP 25 L/M		25	END HOSE Ø 20	880	-	-
FOO35100A	PISTON HAND PUMP 35 L/M		35	END HOSE Ø 20	880	-	-

HAND PUMPS



PUMPS

ACCESSORIES

ATEX

EX50	CODE	DESCRIPTION
	FO0372020	(EX) NAKED DRUM EX50 12 V DC ATEX
	FO037402A	(EX) GRUPPO DRUM EX50 230V/50HZ ATEX



DC PUMPS

BP3000	CODE	DESCRIPTION
	R1601100B	ELECTRICAL BOX WITH SWITCH BP3000
	R17289000	KIT TERMINAL BOX+2M CABLE W\CLAMP 12-24V
	R17018000	KIT TERMINAL BOX+4M CABLE W\CLAMP 12-24V
	F16172000	LP 3/4 STRAIGHT HOSE TAIL KIT (2 PCS.)-N
	F17124000	STRAIGHT HOSE TAIL 1" BP3000
	F1617300A	LP 3/4 90° HOSE TAIL KIT (1 PCS.)
	F1726200A	HOSE TAIL 90° 1"
	F16178000	LP 90° FLANGED ELBOW-NEW
	F16770000	KIT N.1 ELBOW 90° WITHOUT FLANGE
	F16799000	FLANGED ADAPTER BP3000-VANTAGE 1" G-F
	F17314000	FLANGED ADAPTER BP3000\ VANTAGE 3/4ING -F
F17313000	FLANGED ADAPTER BP3000 \ VANTAGE 1ING -	



PANTHER DC	CODE	DESCRIPTION
	R10011000	CABLE 2X6X2 MT EYELET TERMINAL 12V
	R10040000	CABLE 2X6X2 MT EYELET TERMINAL 24V
	R10041000	CABLE 2X6X4 MT EYELET TERMINAL 12V
	R10039000	CABLE 2X6X4 MT EYELET TERMINAL 24V
	R13242000	KIT HANDLE PANTHER DC



BIPUMP	CODE	DESCRIPTION
	R14334000	CABLE 2X6X2MT BI-PUMP
	R14335000	CABLE 2X6X4MT BI-PUMP
	R1420000A	KIT HANDLE BI-PUMP



PIUSI HAND PUMP

PIUSI HAND PUMP	CODE	DESCRIPTION
	R1512800A	ADAPTER M/F 2" - S7OX6 ADBLUE
	F15236000	ADATTATORE M\F 2IN - 56X4 ADBLUE





KKD

METERS

FILTER





DISPENSERS



PUMPS



METERS



NOZZLE



FILTRATION



FLUID MONITORING

K33 ATEX

FEATURES

- BURSTING PRESSURE 28 BAR
- 3 DIGIT DISPLAY
- EASY TO CALIBRATE
- 4 FLOW DIRECTIONS

The PIUSI K33 ATEX is an oval gear mechanical meter engineered for an accurate measuring of the quantity of fluid dispensed that meets the ATEX/IECEx requirements related to the use in potentially explosive atmospheres. Reliable and easy to install, it can be calibrated on site and simply fitted with both rigid or flexible pipes or can be put directly on pumps and tanks.



PERFORMANCE

20-120

L/MIN
FLOW-RATE

3,5 BAR

MAX OPERATING
PRESSURE

± 1%

ACCURACY





K33 - ATEX



OUR PRODUCTS COMPLIES WITH THE FOLLOWING MARKING ATEX

II	2	G	c	IIB	T6
GROUP	CATEGORY	TYPE OF EXPLOSIVE ATMOSPHERE	PROTECTION METHOD	GAS GLASS	TEMPERATURE CLASS

PACKAGING

CODE	WEIGHT		PACKAGING			N. BOXES / EUROPALLET	
	KG	LBS	MM	INCH	PCS/BOX		
FO057000A	0,6	1,3	180X180X170	-	1	192	240
FO057001A	0,6	1,3	180X180X170	-	1	192	240
FO057002A	0,6	1,3	180X180X170	-	1	192	240
FO057003A	0,6	1,3	180X180X170	-	1	192	240



HOSE REELS



ACCESSORIES



MERCHANDISE



AIR



ANTIFREEZE



AdBlue®



BIODIESEL



DIESEL



FOOD



GASOLINE



GREASE



KEROSENE



OIL



WATER



WINDSCREEN

CHART

K33 ATEX

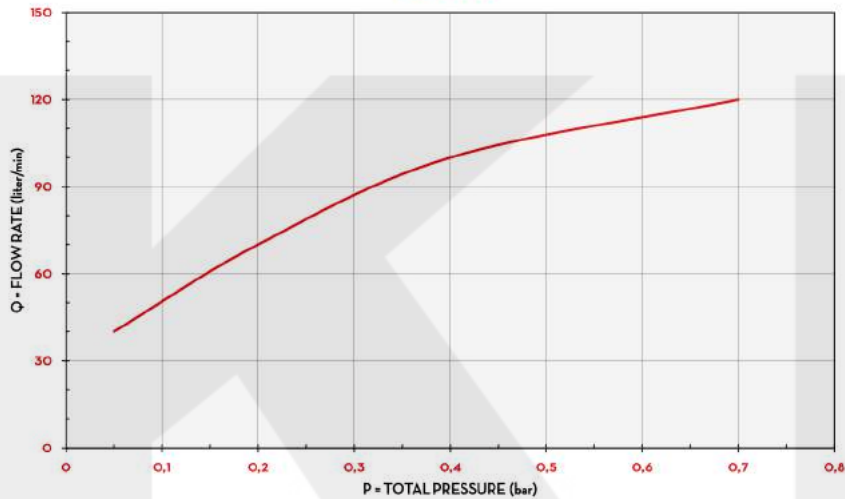

TYPE OF FLUID DIESEL

TEMPERATURE 16 °C

IN THE BOX

- K33 ATEX METER
- INSTRUCTION MANUAL

DETAILS

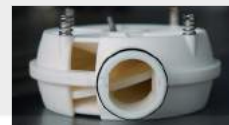

NUTATING DISK SYSTEM



4 FLOW DIRECTIONS



ATEX APPROVED

DIMENSIONS

K33-K44 SIDE

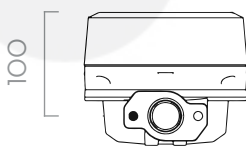

K33-K44 FRONT

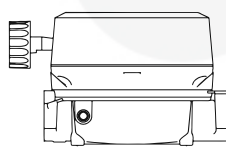

K33-K44 SIDE

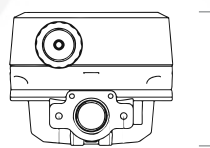

ø34,1" bsp

62

Dimensions expressed in millimeters

MATERIALS

- BODY: ALUMINIUM
- NUTATING DISK CHAMBER: TECHNOPYLIMER

TECHNICAL DATA

CODE	DESCRIPTION	FLUIDS TYPE	FLOW DIRECTION	FLOW-RATE		PRESSURE		INLET / OUTLET
				L/MIN	GPM	BAR	PSI	
FO057000A	K33 - ATEX VER. A	D G K	←	20 - 120	5 - 32	3,5	50	1" BSP
FO057001A	K33 - ATEX VER. B	D G K	↑	20 - 120	5 - 32	3,5	50	1" BSP
FO057002A	K33 - ATEX VER. C	D G K	↓	20 - 120	5 - 32	3,5	50	1" BSP
FO057003A	K33 - ATEX VER. D	D G K	→	20 - 120	5 - 32	3,5	50	1" BSP

FLUIDS PERMITTED: DIESEL, KEROSENE, PETROL, PETROL ALCOHOL MIXED MAX 20%,
AVGAS 100/100LL (PUMP ONLY), JET A/A1 (PUMP ONLY) - ASPEN 2/4. UL CLASSIFIED VERSION AVAILABLE

K33 ATEX



DISPENSERS



PUMPS



METERS



NOZZLE



FILTRATION



FLUID MONITORING

K24 ATEX

FEATURES

- BURSTING PRESSURE 100 BAR
- LCD DISPLAY
- FLOW-RATE INDICATION
- EASY TO CALIBRATE
- UL VERSION AVAILABLE

The PIUSI K24 ATEX, specifically designed to be compliant with ATEX/IECEX requirements, is manufactured using high-quality materials compatible with gasoline, kerosene and diesel to be used in potentially explosive areas. This turbine flow meter is equipped with a 6-digit totalizer and partial reset.

PERFORMANCE

7-120

L/MIN
FLOW-RATE

20 BAR

MAX OPERATING
PRESSURE

± 1%

ACCURACY

0,3%

REPEATIBILITY



K24 ATEX / IECEX



OUR PRODUCT COMPLIES WITH THE FOLLOWING MARKING ATEX/IECEX

II	2	G	Ex	ia	IIB	T4	Gb
GROUP	CATEGORY	TYPE OF EXPLOSIVE ATMOSPHERE	PERMANENT PREFIX	PROTECTION METHOD	GAS GLASS	TEMPERATURE CLASS	EQUIPMENT PROTECTION LEVEL
II	2	G	Ex	ia	IIB	T4	Gb

PACKAGING

CODE	WEIGHT		PACKAGING		
	KG	LBS	MM	INCH	PCS/BOX
K24 A ATEX/IECEX					
FOO408X00	0,5	1,1	115X16OX135	4,5X6,3X5,3	1
K24 A ATEX/IECEX PULSER					
FOO408Y00	0,5	1,1	115X16OX135	4,5X6,3X5,3	1



HOSE REELS



ACCESSORIES



MERCHANDISE



AIR



ANTIFREEZE



AdBlue®



BIODIESEL



DIESEL



FOOD



GASOLINE



GREASE



KEROSENE



OIL



WATER



WINDSCREEN

CHART



IN THE BOX

- K24 ATEX METER
- INSTRUCTION MANUAL

DETAILS



DIMENSIONS

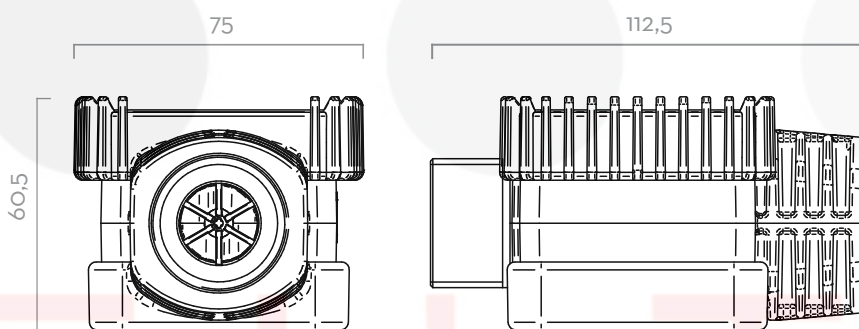

Dimensions expressed in millimeters

MATERIALS

- BODY: ALUMINIUM
- GEARS: TECHNOPOLYMER

TECHNICAL DATA

CODE	DESCRIPTION	FLUIDS TYPE	FLOW-RATE		PRESSURE		SPECIAL BATTERY INCLUDED N° 1.3V LITHIUM	FLANGE	INLET / OUTLET
			L/MIN	GPM	BAR	PSI			
K24 A ATEX/IECEX									
FOO408XOO	K24 A M/F 1" BSP ATEX/IECEX	D G K	7 - 120	2 - 32	20	300	YES	NO	M 1" BSP - F 1" BSP
K24 A ATEX/IECEX PULSER									
FOO408YOO	K24 A PULSER M/F 1" BSP ATEX/IECEX (92 PULSE/L)	D G K	7 - 120	2 - 32	20	300	NO	NO	M 1" BSP - F 1" BSP

FLUIDS PERMITTED: DIESEL, KEROSENE, PETROL, PETROL ALCOHOL MIXED MAX 20%,
AVGAS 100/100LL (PUMP ONLY), JET A/A1 (PUMP ONLY) - ASPEN 2/4. UL CLASSIFIED VERSION AVAILABLE



DISPENSERS



PUMPS



METERS



NOZZLE



FILTRATION



FLUID MONITORING

K24

FEATURES

- BURSTING PRESSURE 100 BAR
- LCD DISPLAY
- FLOW-RATE INDICATION
- EASY TO CALIBRATE

The PIUSI K24 is a turbine digital flow meter specifically designed for diesel. Easy to install in-line or at the end of a delivery pipe, it is equipped with a rotatable display. This meter is available both with aluminium or technopolymer body.

PERFORMANCE

7-120

L/MIN
FLOW-RATE

20 BAR

MAX OPERATING
PRESSURE

± 1%

ACCURACY

0,2%

REPEATIBILITY



K24



K24 plastic version



K24 PULSER

PACKAGING

CODE	WEIGHT		PACKAGING		
	KG	LBS	MM	INCH	PCS/BOX
K24					
FOO40700A	0,5	1,1	BLISTER	BLISTER	1
FOO408100	0,5	1,1	BLISTER	BLISTER	1
K24 PULSER					
FOO40722A	0,5	1,1	115X16OX135	4,5X6,3X5,3	1



HOSE REELS



ACCESSORIES



MERCHANDISE



AIR



ANTIFREEZE



AdBlue®



BIODIESEL



DIESEL



FOOD



GASOLINE



GREASE



KEROSENE



OIL



WATER



WINDSCREEN

CHART



IN THE BOX

- K24 UNIT
- INSTRUCTION MANUAL
- SOCKET F/F

DETAILS



ROTABLE DISPLAY



BI-DIRECTIONAL



TURBINE PULSE METER



SOCKET F/F

DIMENSIONS

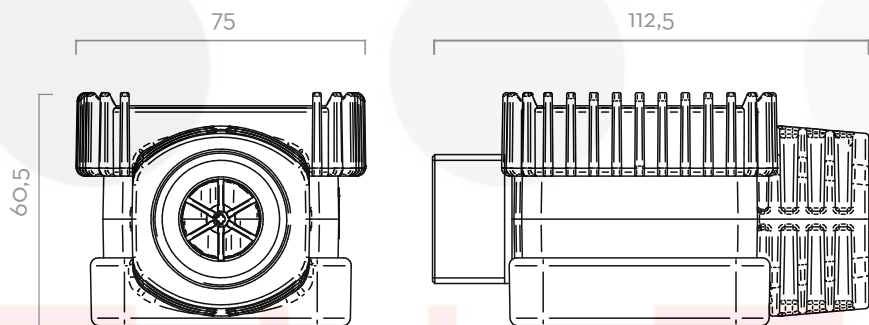

Dimensions expressed in millimeters

MATERIALS

- BODY: ALUMINIUM
- GEARS: TECHNOPOLYMER

TECHNICAL DATA

CODE	DESCRIPTION	FLUIDS TYPE	FLOW-RATE		PRESSURE		BATTERY	FLANGE	INLET / OUTLET
			L/MIN	GPM	BAR	PSI	2X AAA BATTERY 1,5V (INCLUDED)		
K24									
FO040700A	K24 METER M/MF LITER BLACK 1INBSP	D	7 - 120	2 - 32	10	150	YES	NO	M 1" BSP - M 1" BSP
FO0408100	K24 M/F 1" BSP	D	7 - 120	2 - 32	20	300	YES	NO	M 1" BSP - F 1" BSP
K24 PULSER									
FO040722A	K24 PULSER M/MF LITER BLACK 1INBSP	D	7 - 120	2 - 32	10	150	NO	NO	M 1" BSP - M 1" BSP

UPON REQUEST AVAILABLE IN NPTF VERSION AND DISPLAY IN GALLON/QUARTER OR PRINT
*N° 2X1,5V BATTERY INCLUDED

K24



DISPENSERS



PUMPS



METERS



NOZZLE



FILTRATION



FLUID
MONITORING

K600/3

FEATURES

- ADJUSTABLE FLANGES
- SUITABLE FOR INDUSTRIAL APPLICATIONS
- IDEAL FOR MOBILE INSTALLATIONS
- LOW ENERGY CONSUMPTIONS

The PIUSI K600/3 is an oval gear meter suitable for monitoring the delivery of diesel, oil and antifreeze. The meter is equipped with an integrated filter and is also available in pulser version.

PERFORMANCE

UP TO

100 L/MIN

FLOW-RATE

0,2%

REPEATIBILITY

± 0,5%

ACCURACY



K600/3 METER



K600/3 PULSER

PACKAGING

CODE	WEIGHT		PACKAGING		
	KG	LBS	MM	INCH	PCS/BOX
METERS					
FOO496A00	1,6	3,5	200X120X140	79X4,7X5,5	1
PULSER					
FOO472A00	2,6	5,7	200X120X140	79X4,7X5,5	1



HOSE REELS



ACCESSORIES



MERCHANDISE



AIR



ANTIFREEZE



AdBlue®



BIODIESEL



DIESEL



FOOD



GASOLINE



GREASE



KEROSENE



OIL



WATER



WINDSCREEN

CHART

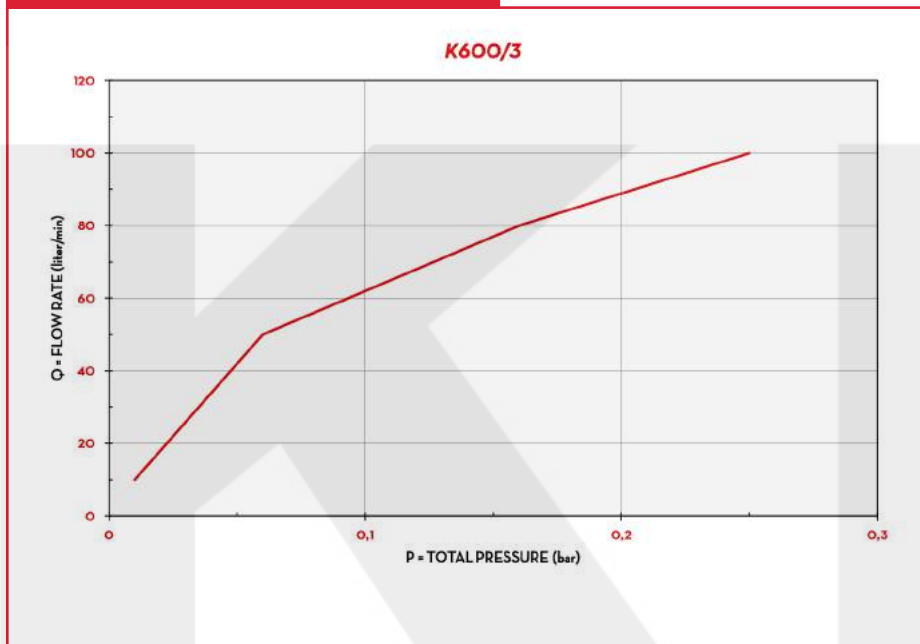

IN THE BOX

- K600/3 METER
- FLANGES
- INSTRUCTION MANUAL

DETAILS



5-DIGIT DISPLAY



OVAL GEARS

DIMENSIONS

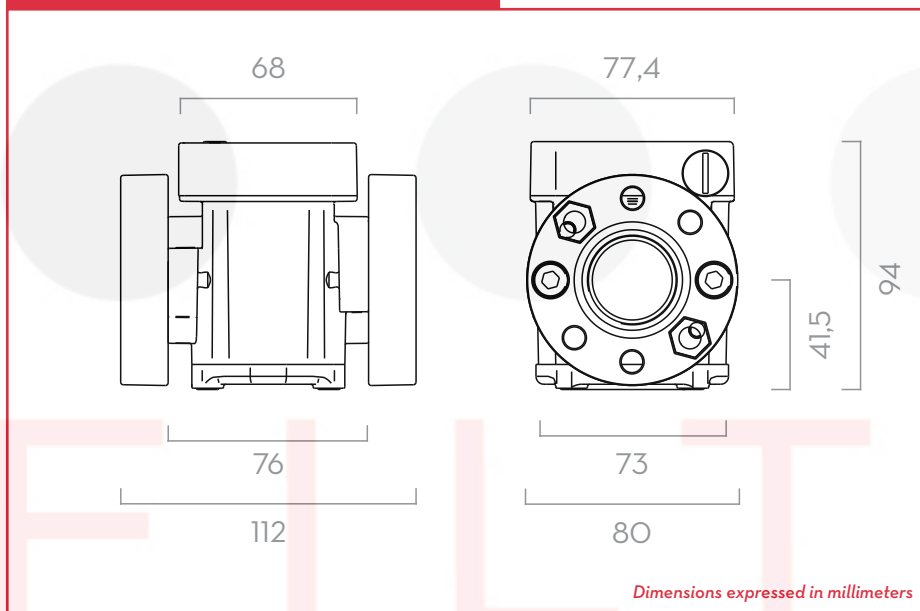

MATERIALS

- BODY: ALUMINIUM
- GEARS: TECHNOPOLYMER

TECHNICAL DATA

CODE	DESCRIPTION	FLUIDS TYPE	FLOW-RATE		PRESSURE		BATTERY N°2 X 1,5V (INCLUDED)	FLANGE	INLET / OUTLET	INLET FILTER
			L/MIN	GPM	BAR	PSI				
METERS										
FOO496A00	K600/3 DIESEL	A D O	10 - 100	2,64 - 26,4	30	426	YES	YES	1" BSP	YES
PULSER										
FOO472A00	K600/3 1" DIESEL	A D O	10 - 100	2,64 - 26,4	30	426	NO	YES	1" BSP	YES

UPON REQUEST AVAILABLE IN NPTF VERSION AND DISPLAY IN GALLON/QUARTER OR PRINT

K600/3



DISPENSERS



PUMPS



METERS



NOZZLE



FILTRATION



FLUID MONITORING

K600 B/3

FEATURES

- BETTER VISIBILITY
- ADJUSTABLE FLANGES
- ROTATING DISPLAY
- STANDARD BATTERY
- PULSE-OUT VERSION AVAILABLE
- IP66

The PIUSI K600 B/3 is an oval gear meter suitable for monitoring the delivery of diesel, biodiesel and antifreeze. This special version includes a large 80mm built-in digital display that can be rotated to suit every application. Among its features: 5-digit partial total and resettable total. Pulser version available.

PERFORMANCE

UP TO

100 L/MIN

FLOW-RATE

0,2%

REPEATIBILITY

± 0,5%

ACCURACY



K600 B/3 METER



K600 B/3 WITH PULSE-OUT



PACKAGING

CODE	WEIGHT		PACKAGING		
	KG	LBS	MM	INCH	PCS/BOX
METERS					
FOO491000	2	4,4	200X120X140	79X4,7X5,5	1
PULSE OUT METER					
FOO492000	2	4,4	200X120X140	79X4,7X5,5	1



HOSE REELS



ACCESSORIES



MERCHANDISE



AIR



ANTIFREEZE



AdBlue®



BIODIESEL



DIESEL



FOOD



GASOLINE



GREASE



KEROSENE



OIL



WATER



WINDSCREEN

CHART

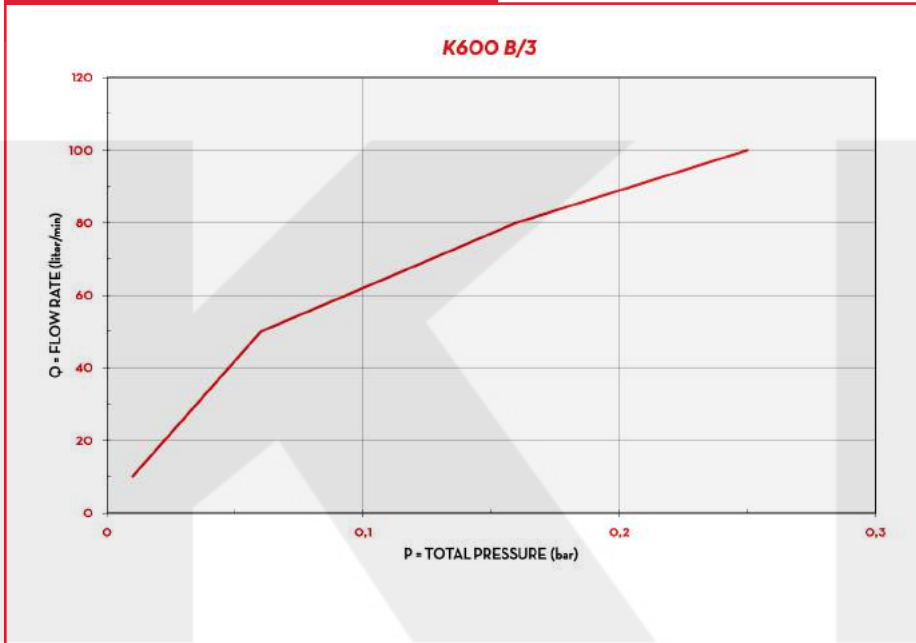

IN THE BOX

- K600 B/3 METER
- FLANGES
- INSTRUCTION MANUAL

DETAILS



5-DIGIT DISPLAY



OVAL GEARS



BIG AND ROTATING DISPLAY

DIMENSIONS

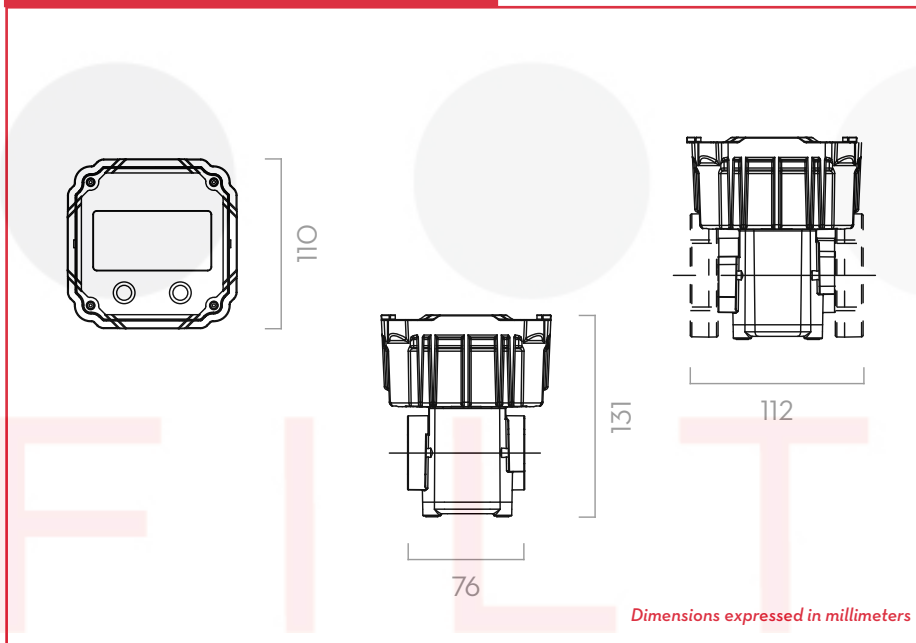

MATERIALS

- BODY: ALUMINIUM
- GEARS: TECHNOPOLYMER

TECHNICAL DATA

CODE	DESCRIPTION	FLUIDS TYPE	FLOW-RATE		PRESSURE		BATTERY N°2 X 1,5V (INCLUDED)	FLANGE	INLET / OUTLET	INLET FILTER
			L/MIN	GPM	BAR	PSI				
METERS										
FOO491000	K600 B/3	D	10 - 100	2,64 - 26,4	30	426	YES	YES	1" BSP	YES
PULSE OUT METER										
FOO492000	K600 B/3 WITH PULSE-OUT	D	10 - 100	2,64 - 26,4	30	426	YES	YES	1" BSP	YES

UPON REQUEST AVAILABLE IN NPTF VERSION AND DISPLAY IN GALLON/QUARTER OR PRINT

K600 B/3



DISPENSERS



PUMPS



METERS



NOZZLE



FILTRATION



FLUID MONITORING

K600/4

FEATURES

- EASY TO INSTALL AND TO CALIBRATE
- VERSATILE
- HIGH PRECISION

The PIUSI K600/4 is an oval gear meter suitable for monitoring the delivery of fuels. This special version is particularly suitable for all applications in the industrial sector.

PERFORMANCE

15-150

L/MIN

FLOW-RATE

20 BAR

MAX OPERATING

PRESSURE

± 0,5%

ACCURACY



K600/4



K600/4 PULSER

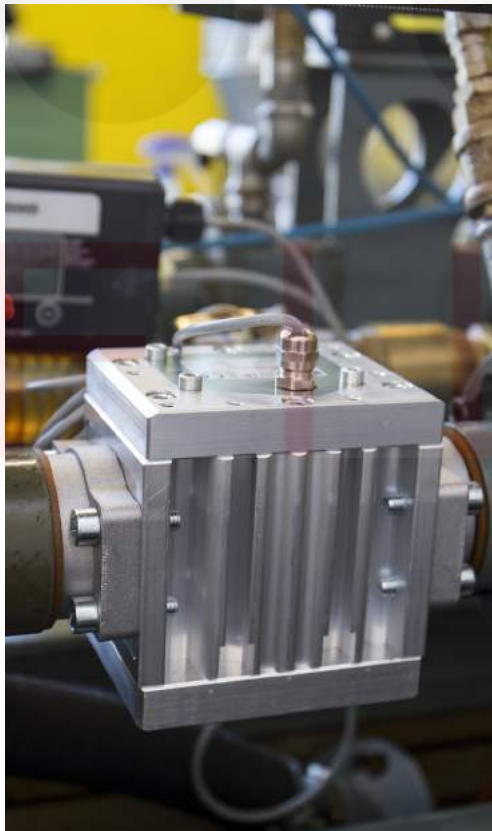

PACKAGING

CODE	WEIGHT		PACKAGING		
	KG	LBS	MM	INCH	PCS/BOX
METERS					
00049700A	3,2	7	200X120X140	79X4,7X5,5	1
PULSER					
000473000	3,2	7	200X120X140	79X4,7X5,5	1



HOSE REELS



ACCESSORIES



MERCHANDISE



AIR



ANTIFREEZE



AdBlue®



BIODIESEL



DIESEL



FOOD



GASOLINE



GREASE



KEROSENE



OIL



WATER



WINDSCREEN

CHART**IN THE BOX**

- K600/4 METER
- FLANGES
- INSTRUCTION MANUAL

DETAILS

5-DIGIT DISPLAY

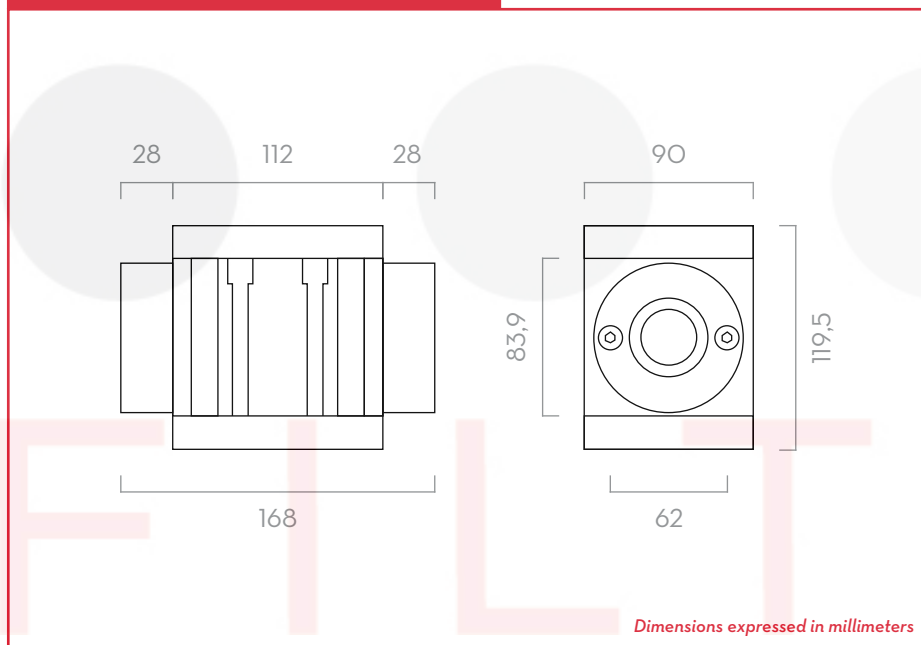

OVAL GEARS

DIMENSIONS**MATERIALS**

- BODY: ALUMINIUM
- GEARS: TECHNOPOLYMER

TECHNICAL DATA

CODE	DESCRIPTION	FLUIDS TYPE	FLOW-RATE		PULSER		PRESSURE		BATTERY N°2 X 1,5V (INCLUDED)	FLANGE	INLET / OUTLET	INLET FILTER
			L/MIN	GPM	P/L	GPM	BAR	PSI				
METERS												
00049700A	K600/4		15 - 150	3,9 - 39	-	-	20	284	YES	YES	11/2" BSP	YES
PULSER												
000473000	K600/4 PULSER		15 - 150	3,9 - 39	26	98	20	300	NO	YES	11/2"	YES

UPON REQUEST AVAILABLE IN NPT VERSION.

K600/4



DISPENSERS



PUMPS



METERS



NOZZLE



FILTRATION



FLUID MONITORING

K700 PULSER

FEATURES

- EASY TO INSTALL AND TO CALIBRATE
- VERSATILE
- HIGH FLOW RATE
- HEAVY DUTY
- INDUSTRIAL APPLICATIONS

The PIUSI K700 PULSER is an oval gear electronic meter with acetal resin gears. This pulse meter easily interfaces with management systems, making it the ideal solution to fit fuel distributors. It is also suitable for tanks and cisterns, loading arms controlling the consumption of fuel in burners or generator sets, besides other applications.

PERFORMANCE

25-250

L/MIN
FLOW-RATE

20 BAR

MAX OPERATING
PRESSURE

± 0,5%

ACCURACY

0,2%

REPEATIBILITY



K700 PULSER



PACKAGING

CODE	WEIGHT		PACKAGING		
	KG	LBS	MM	INCH	PCS/BOX
PULSER					
FOO49800A	5,5	12	280X160X140	11X6,3X5,5	1



HOSE REELS



ACCESSORIES



MERCHANDISE



AIR



ANTIFREEZE



AdBlue®



BIODIESEL



DIESEL



FOOD



GASOLINE



GREASE



KEROSENE



OIL



WATER



WINDSCREEN

CHART

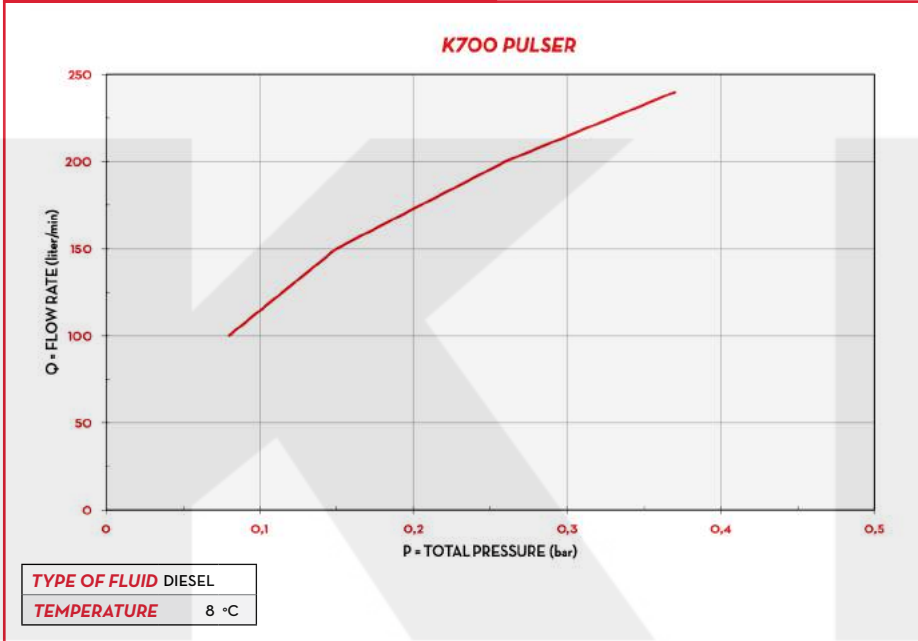

IN THE BOX

- K700 PULSER UNIT
- INSTRUCTION MANUAL

DETAILS



INBUILT SUCTION FILTER



OVAL GEARS

DIMENSIONS

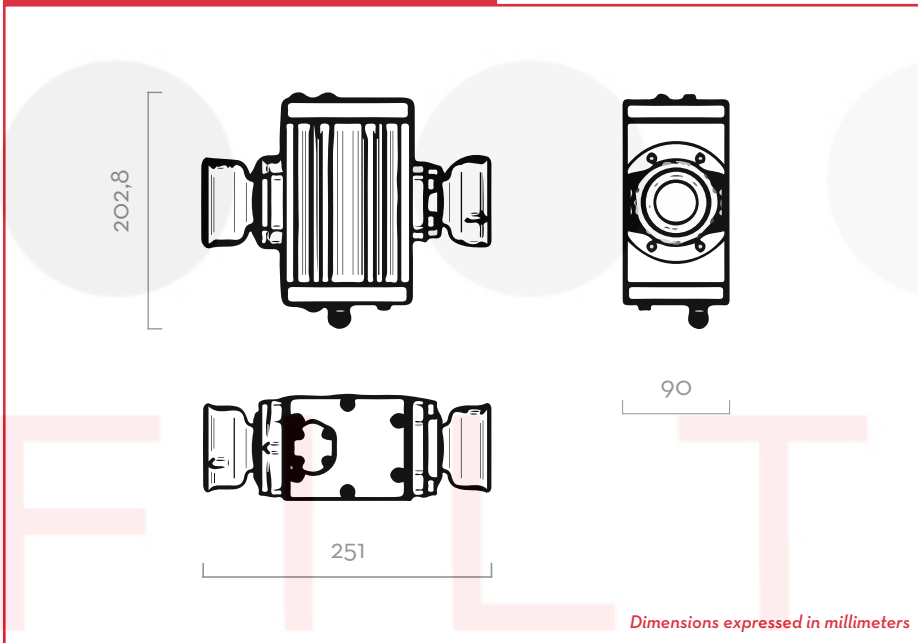

MATERIALS

- BODY: ALUMINIUM
- GEARS: TECHNOPOLYMER

TECHNICAL DATA

CODE	DESCRIPTION	FLUIDS TYPE	FLOW-RATE		PULSER		PRESSURE		BATTERY N°2 X 1,5V (INCLUDED)	FLANGE	INLET / OUTLET	INLET FILTER
			L/MIN	GPM	P/L	GPM	BAR	PSI				
PULSER												
FOO49800A	K700 PULSER	A B D O	25 - 250	6,6 - 66	14	53	20	300	NO	YES	2" BSP	YES

UPON REQUEST AVAILABLE IN NPT VERSION.

K700 PULSER



DISPENSERS



PUMPS



METERS



NOZZLE



FILTRATION



FLUID
MONITORING

K900

FEATURES

- **STURDY STRUCTURE**
- **HEAVY DUTY CONDITIONS**
- **HIGH FLOW RATE APPLICATIONS**
- **READY TO INSTALL**

Among the electronic flow meters Made in Italy by PIUSI, the K900 is the oval gear measuring equipment suitable for controlling the non commercial dispensing of low, medium and high viscosity fluids compatible with its construction materials. This meter is equipped with an in-built suction filter, 3" inlet/outlet and free contact signal pulser.

PERFORMANCE

50-500

L/MIN
FLOW-RATE

20 BAR

MAX OPERATING
PRESSURE

± 0,5%

ACCURACY

0,2%

REPEATIBILITY



K900



PACKAGING

CODE	WEIGHT		PACKAGING		
	KG	LBS	MM	INCH	PCS/BOX
METERS					
FOO49900B	12	26,5	400X290X200	15,7X11,4X7,9	1
PULSER					
FOO49902B	12	26,5	400X290X200	15,7X11,4X7,9	1



HOSE REELS



ACCESSORIES



MERCHANDISE



AIR



ANTIFREEZE



AdBlue®



BIO DIESEL



DIESEL



FOOD



GASOLINE



GREASE



KEROSENE



OIL



WATER



WINDSCREEN

CHART



TYPE OF FLUID DIESEL

TEMPERATURE 19 °C

IN THE BOX

- K900 UNIT
- INSTRUCTION MANUAL

DETAILS



INBUILT FILTER



OVAL GEARS



5 DIGIT PARTIAL TOTAL



IN/OUT 3"

DIMENSIONS

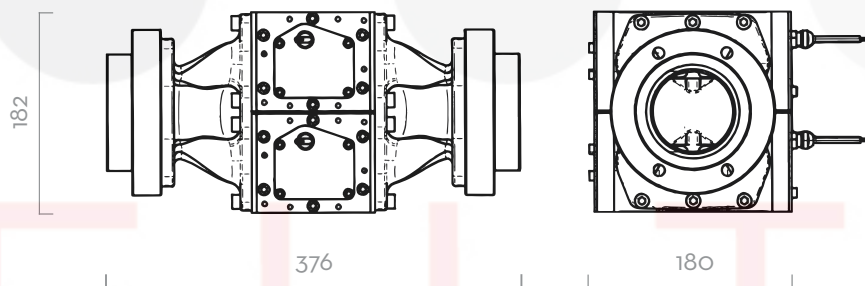

Dimensions expressed in millimeters

MATERIALS

- BODY: ALUMINIUM
- GEARS: TECHNOPOLYMER

TECHNICAL DATA

CODE	DESCRIPTION	FLUIDS TYPE	FLOW-RATE		PULSER		PRESSURE		BATTERY N°2 X 1,5V (INCLUDED)	FLANGE	INLET / OUTLET	INLET FILTER
			L/MIN	GPM	P/L	GPM	BAR	PSI				
METERS												
FO049900B	K900	B D	50 - 500	13,2 - 132	-	-	20	284	YES	YES	3" BSP	YES
PULSER												
FO049902B	K900 PULSER	B D	50 - 500	13,2 - 132	10	38	20	284	YES	YES	3" BSP	YES

UPON REQUEST AVAILABLE IN NPT VERSION. DISPLAY POWER SUPPLY 4-12VDC, 1.2 AMP. TYPE OF OUTPUT SIGNAL: OPEN COLLECTOR MAX 50V, 1.2 AMP, SINGLE CHANNEL.

K900



DISPENSERS



PUMPS



METERS



NOZZLE



FILTRATION



FLUID MONITORING

REMOTE DISPLAY

FEATURES

- **LARGE SCREEN DISPLAY**
- **NON RESETTABLE TOTAL**
- **STANDARD BATTERY**

Remote display for remote control (via max. 15 m. cable) of pulse meters. The large screen displays the quantity delivered and the non resettable total. Equipped with software applications for calibrating meters. Available as both basic display device and as pulse emitter. Indispensable for receivers designed to recognise only discreet quantities of impulses. The easy interfacing management systems of the pulse transmitter models extend the field of application of pulse meters combined with remote displays.

PERFORMANCE

every

PULSE METER

COMPATIBILITY

UP TO

100

PULSES/LITER

FLOW-RATE



REMOTE DISPLAY



PACKAGING

CODE	WEIGHT		PACKAGING		
	KG	LBS	MM	INCH	PCS/BOX
F1175200B	1,2	2,6	200X120X140	7,9X4,7X5,5	1
F1175300B	1,2	2,6	200X120X140	8,9X4,9X5,9	1
F1175400B	1,2	2,6	200X120X140	8,9X4,9X5,9	1
FO049501A	1,2	2,6	200X120X140	8,9X4,9X5,9	1
FO049502A	1,2	2,6	200X120X140	8,9X4,9X5,9	1
FO049503B	1,2	2,6	225X125X150	8,9X4,9X5,9	1



HOSE REELS



ACCESSORIES



MERCHANDISE



AIR



ANTIFREEZE



AdBlue®



BIODIESEL



DIESEL



FOOD



GASOLINE



GREASE



KEROSENE



OIL



WATER



WINDSCREEN

FUNCTIONING SCHEME

Remote display battery powered

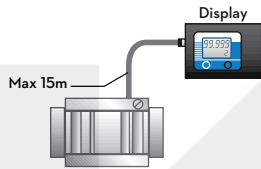

Remote display battery powered

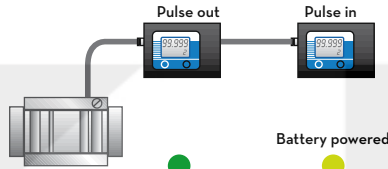

Display pulse transmitter battery powered

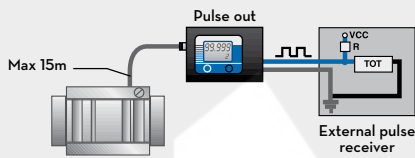

Display pulse transmitter externally powered

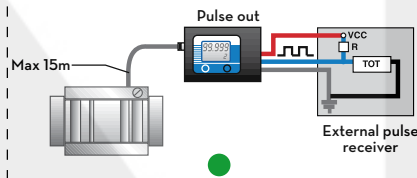

IN THE BOX

- REMOTE DISPLAY
- BRACKET
- INSTRUCTION MANUAL

DETAILS



5 DIGITS PARTIAL TOTAL

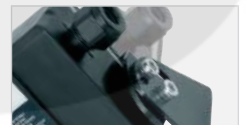

ADJUSTABLE BRACKET

DIMENSIONS

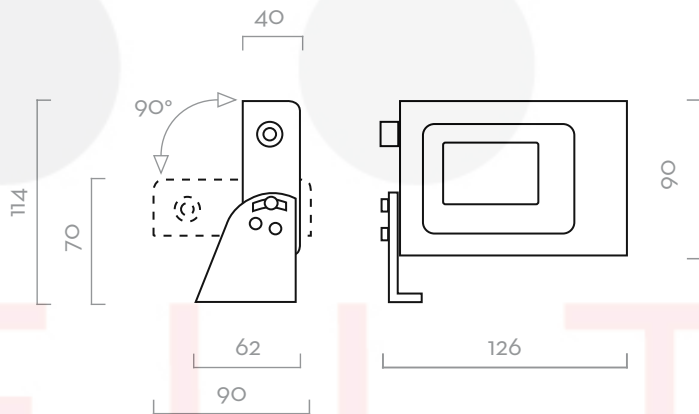

Dimensions expressed in millimeters

TECHNICAL DATA

CODE	DESCRIPTION	FLUIDS TYPE	FLANGE	INLET OUTLET
F1175200B	REMOTE DISPLAY PULSE OUT K600	Ad B D O W W	K600 DIESEL	PULSE OUT ●
F1175300B	REMOTE DISPLAY PULSE OUT K600/4	Ad B D O W W	K600/4	PULSE OUT ●
F1175400B	REMOTE DISPLAY PULSE OUT K700	Ad B D O W W	K700	PULSE OUT ●
FO049501A	UNIVERSAL DISPLAY PULSE OUT	Ad B D O W W	K200, K400, K600 OIL, K600 DIESEL, K600/4, K700	PULSE OUT ●
FO049502A	DISPLAY PULSE IN	Ad B D O W W	FOR ALL PIUSI PULSE OUT REMOTE DISPLAY	PULSE IN ●
FO049503B	DISPLAY PULSE OUT ADBLUE®	Ad B D O W W	TURBINOX / K24 PULSER	PULSE OUT ●

REMOTE DISPLAY



DISPENSERS



PUMPS



METERS



NOZZLE



FILTRATION

FLUID
MONITORING

K33 / K44

FEATURES

- **READY TO USE**
- **BURSTING PRESSURE 30 BAR**
- **NO BATTERY NEEDED**
- **EASY TO INSTALL AND CALIBRATE**
- **4 FLOW DIRECTION**

The PIUSI K33 and K44 are the bestseller mechanical meters in this market. Reliable, easy to install and to calibrate, they are equipped with a nutating disk that allows them to be installed in all four flow directions. The display is available in both three or four digits, according to the model chosen.

PERFORMANCE

20-120

L/MIN

FLOW-RATE

10 BAR

MAX OPERATING

PRESSURE

± 1%

ACCURACY



K33

K44

PACKAGING

CODE	WEIGHT		PACKAGING			N. BOXES / EUROPALET	
	KG	LBS	MM	INCH	PCS/BOX	✈	🚚
METERS							
000550000	0,6	1,3	180X180X170	-	1	192	240
000551000	0,6	1,3	180X180X170	-	1	192	240
000552000	0,6	1,3	180X180X170	-	1	192	240
000553000	0,6	1,3	180X180X170	-	1	192	240
000560000	0,6	1,3	180X180X170	-	1	192	240
000561000	0,6	1,3	180X180X170	-	1	192	240
000562000	0,6	1,3	180X180X170	-	1	192	240
000563000	0,6	1,3	180X180X170	-	1	192	240
PULSER							
00056500A	0,6	1,3	180X180X170	-	1	192	240



HOSE REELS



ACCESSORIES



MERCHANDISE



AIR



ANTIFREEZE



AdBlue®



BIODIESEL



DIESEL



FOOD



GASOLINE



GREASE



KEROSENE



OIL



WATER



WINDSCREEN

CHART

K33 - K44

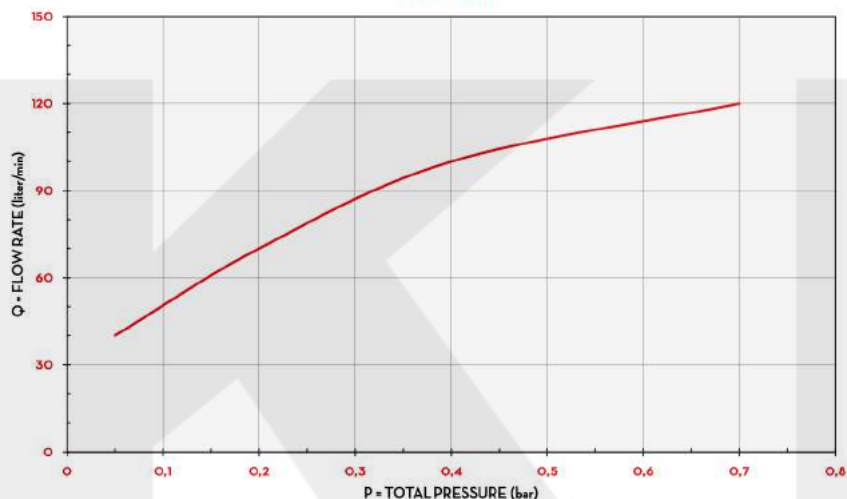

TYPE OF FLUID DIESEL

TEMPERATURE 16 °C

IN THE BOX

- K33 - K44 METER
- INSTRUCTION MANUAL

DETAILS



NUTATING DISK SYSTEM



4 FLOW DIRECTIONS

DIMENSIONS

K33-K44 SIDE

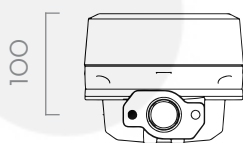

100

K33-K44 FRONT

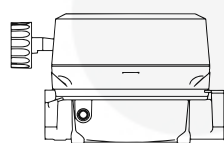

104

176

K33-K44 SIDE

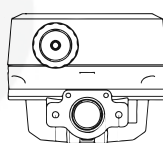

128

ø34,1" bsp

62

Dimensions expressed in millimeters

MATERIALS

- BODY: ALUMINIUM
- NUTATING DISK CHAMBER: TECHNOPYLIMER

TECHNICAL DATA

CODE	DESCRIPTION	FLUIDS TYPE	FLOW DIRECTION	FLOW-RATE		PRESSURE		PULSER P/L (P/GAL)	INLET / OUTLET
				L/MIN	GPM	BAR	PSI		
METERS									
000550000	K33 VER. A	D	←	20 - 120	5 - 32	10	142	-	1" BSP
000551000	K33 VER. B	D	↑	20 - 120	5 - 32	10	142	-	1" BSP
000552000	K33 VER. C	D	↓	20 - 120	5 - 32	10	142	-	1" BSP
000553000	K33 VER. D	D	→	20 - 120	5 - 32	10	142	-	1" BSP
000560000	K44 VER. A	D	←	20 - 120	5 - 32	10	142	-	1" BSP
000561000	K44 VER. B	D	↑	20 - 120	5 - 32	10	142	-	1" BSP
000562000	K44 VER. C	D	↓	20 - 120	5 - 32	10	142	-	1" BSP
000563000	K44 VER. D	D	→	20 - 120	5 - 32	10	142	-	1" BSP
PULSER									
00056500A	K44 PULSER	D	→	20 - 120	5 - 32	10	142	10 (38)	1" BSP

K33 / K44



DISPENSERS



PUMPS



METERS



NOZZLE



FILTRATION

FLUID
MONITORING

K700

FEATURES

- HEAVY DUTY CONDITIONS
- STURDY STRUCTURE
- BURSTING PRESSURE 30 BAR
- NO BATTERY NEEDED
- EASY TO INSTALL
- 2 FLOW DIRECTION

Medium-high flow rates require specific measuring equipment able to adapt precisely to the flow: It is the case of the oval gear mechanical flow meter PIUSI K700: a sturdy, reliable and easy to install equipment suitable for the most demanding environments. The meter displays 4-digit piece of equipment partial total that can show up to a maximum of 9999 liters.

PERFORMANCE

40-220

L/MIN

FLOW-RATE

10 BAR

MAX OPERATING

PRESSURE

± 1,5%

ACCURACY



K700



PACKAGING

CODE	WEIGHT		PACKAGING			N. BOXES / EUROPALLET	
	KG	LBS	MM	INCH	PCS/BOX	✈	🚚
FO0540000	5,8	12,8	240X240X275	-	1	48	72
FO0540020	5,8	12,8	240X240X275	-	1	48	72
FO0540030	5,8	12,8	240X240X275	-	1	48	72
FO0540040	5,8	12,8	240X240X275	-	1	48	72



HOSE REELS



ACCESSORIES



MERCHANDISE



AIR



ANTIFREEZE



AdBlue®



BIO DIESEL



DIESEL



FOOD



GASOLINE



GREASE



KEROSENE



OIL



WATER



WINDSCREEN

CHART

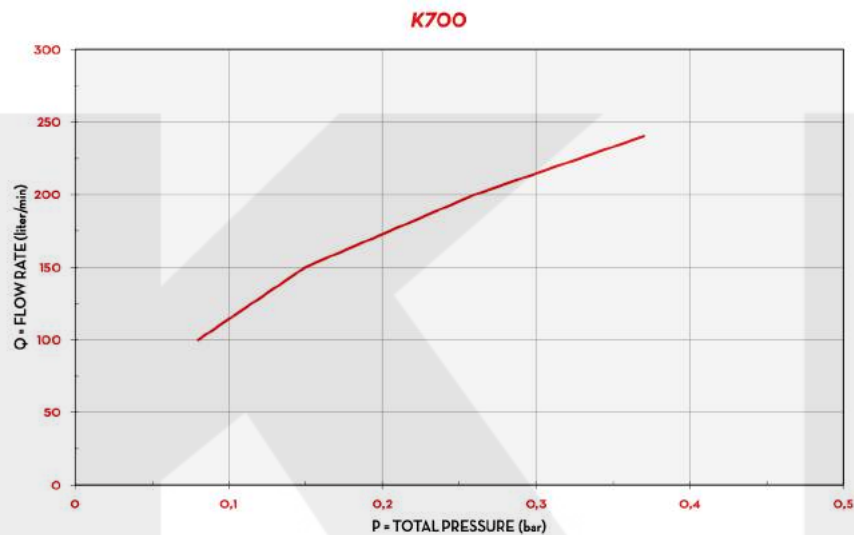

TYPE OF FLUID DIESEL

TEMPERATURE 8 °C

IN THE BOX

- K700 METER
- INSTRUCTION MANUAL

DETAILS



4-DIGITS



OVAL GEARS



4 FLOW DIRECTIONS

MATERIALS

- BODY: ALUMINIUM
- GEARS: TECHNOPYLIMER

DIMENSIONS

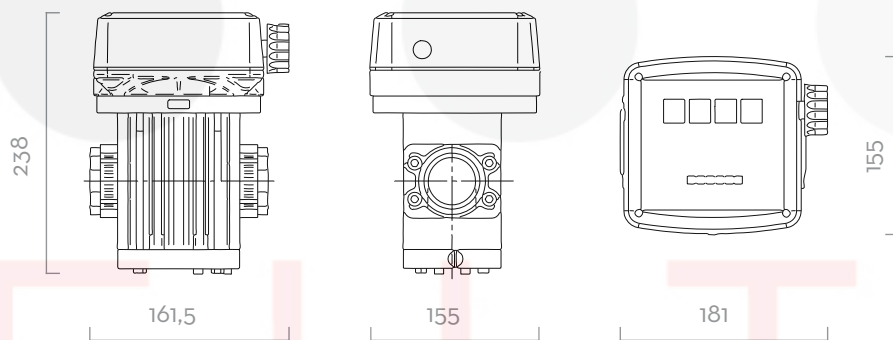

Dimensions expressed in millimeters

TECHNICAL DATA

CODE	DESCRIPTION	FLUIDS TYPE	FLOW DIRECTION	FLOW-RATE		PRESSURE		INLET FILTER	INLET / OUTLET
				L/MIN	GPM	BAR	PSI		
FO0540000	K700 VER. A	D	←	40 - 220	5 - 53	10	142	YES	1" 1/2 BSP
FO0540020	K700 VER. B	D	↑	40 - 220	5 - 32	10	142	YES	1" 1/2 BSP
FO0540030	K700 VER. C	D	↓	40 - 220	5 - 53	10	142	YES	1" 1/2 BSP
FO0540040	K700 VER. D	D	→	40 - 220	5 - 32	10	142	YES	1" 1/2 BSP

K700

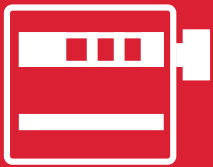

METERS ACCESSORIES

ELECTRONIC

K24	CODE	DESCRIPTION
	FOO49501A	REMOTE DISPLAY PULS OUT UNIVERSAL
	FOO49502A	UNIVERSAL REMOTE DISPLAY PULS IN



FOO49501A
FOO49502A

K600/3 PULSER	CODE	DESCRIPTION
	FOO49501A	REMOTE DISPLAY PULS OUT UNIVERSAL
	FOO49502A	UNIVERSAL REMOTE DISPLAY PULS IN



FOO49501A
FOO49502A

K600/3 METER	CODE	DESCRIPTION
	F1175200B	REMOTE DISPLAY PULS OUT K600/3 LT SEL



F1175200B

K600/4	CODE	DESCRIPTION
	FOO49501A	REMOTE DISPLAY PULS OUT UNIVERSAL
	FOO49502A	UNIVERSAL REMOTE DISPLAY PULS IN
	F1175300B	REMOTE DISPLAY PULS OUT K600/4 LT SEL



FOO49501A
FOO49502A
F1175300B

K700 PULSER	CODE	DESCRIPTION
	FOO49501A	REMOTE DISPLAY PULS OUT UNIVERSAL
	FOO49502A	UNIVERSAL REMOTE DISPLAY PULS IN
	F1175400B	REMOTE DISPLAY PULS OUT K700 LT SEL



FOO49501A
FOO49502A
F1175300B

K900	CODE	DESCRIPTION
	FOO49501A	REMOTE DISPLAY PULS OUT UNIVERSAL
	FOO49502A	UNIVERSAL REMOTE DISPLAY PULS IN



FOO49501A
FOO49502A





KKD

NOZZLES

FILTER





DISPENSERS



PUMPS



METERS



NOZZLES



FILTRATION



FLUID MONITORING

A60 ATEX

FEATURES

- AUTOMATIC
- READY TO USE
- STURDY DESIGN

Expressly engineered to meet the strictest requirements of the ATEX/IECEX regulations, the PIUSI A60 ATEX is an automatic nozzle suitable to dispense fluids - such as gasoline, kerosene, diesel and others - in potentially explosive atmospheres. It is fitted with a structural component that automatically stops dispensing when the tank is full.



PERFORMANCE

UP TO

60 L/MIN

FLOW-RATE

1" BSP

INLET

Ø20MM

SPOUT



A60 ATEX



PACKAGING

CODE	WEIGHT		PACKAGING			N. BOXES / EUROPALLET	
	KG	LBS	MM	INCH	PCS/BOX		
FO0613020	1,25	2,76	460X200X80	181X78X31	1		



HOSE REELS



ACCESSORIES



MERCHANDISE



AIR



ANTIFREEZE



AdBlue®



BIODIESEL



DIESEL



FOOD



GASOLINE



GREASE



KEROSENE



OIL



WATER



WINDSCREEN

CHART

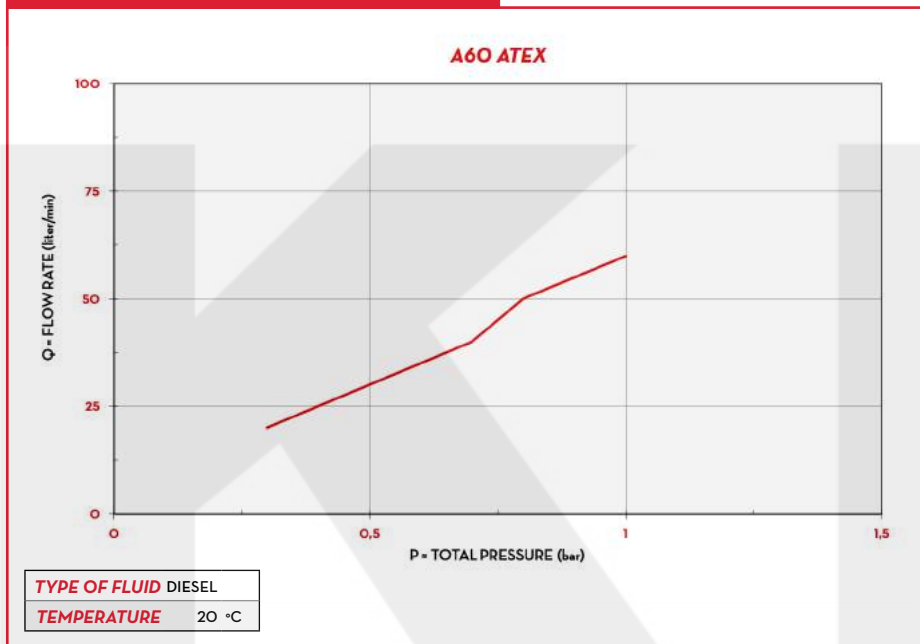

IN THE BOX

- A60 ATEX NOZZLE
- INSTRUCTION MANUAL

DETAILS



AUTOMATIC STOP



F 1" SWIVEL

DIMENSIONS

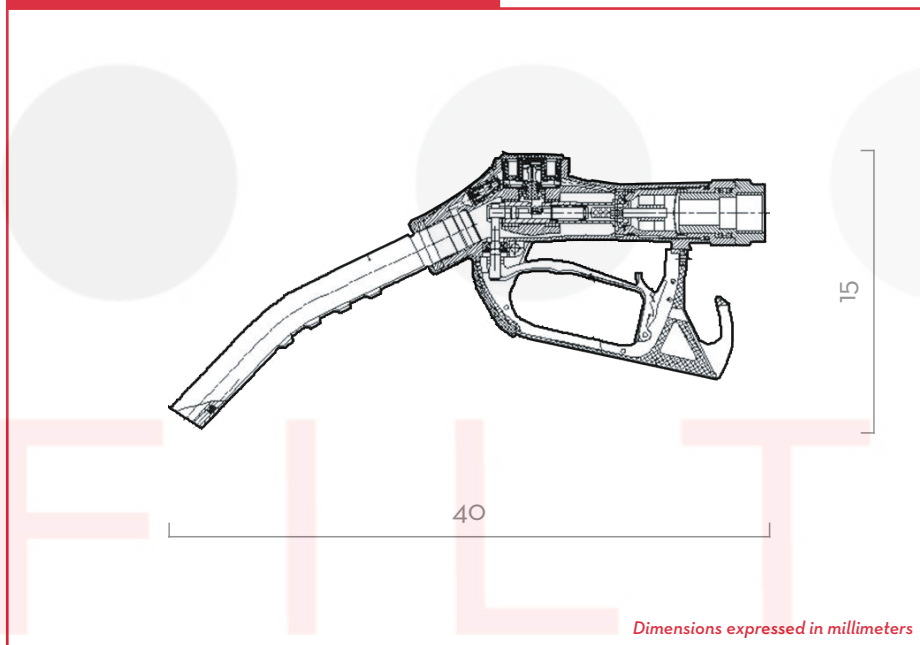

MATERIALS

- BODY: ALUMINIUM
- SEAL: NBR

TECHNICAL DATA

CODE		DESCRIPTION	FLUIDS TYPE	FLOW-RATE		INLET		SPOUT
WITHOUT SWIVEL	WITH SWIVEL			L/MIN	GPM	WITHOUT SWIVEL BSP	WITH SWIVEL BSP	EXT. Ø MM
-	FOO613020	A60 ATEX	D G K	60	16	-	F 1"	20



DISPENSERS



PUMPS



METERS



NOZZLES



FILTRATION

FLUID
MONITORING

A60 / A80 / A120

FEATURES

- AUTOMATIC
- READY TO USE
- STURDY DESIGN

Among the range of nozzles for fuel dispensing, PIUSI A60/A80/A120 consist of a range of automatic devices for flow rates up to 120 l/min fitted with an inner device that automatically stops the fluid dispensing when the tank is full. These nozzles also include a swivel connector.

PERFORMANCE

UP TO
120 L/MIN

FLOW-RATE

1" BSP

INLET

24MM
OD SPOUT

A60

29MM
OD SPOUT

A80/A120



PACKAGING

CODE	WEIGHT		PACKAGING			N. BOXES / EUROPALET	
	KG	LBS	MM	INCH	PCS/BOX		
FO0603060	1,25	2,76	36OX36OX280	14X14X11	1		
FO0602020	1,20	2,65	36OX36OX280	14X14X11	1		
FO0604030	1,93	4,25	36OX36OX280	14X14X11	1		
FO0610020	1,93	4,25	36OX36OX280	14X14X11	1		
FO0613A00	1,30	2,87	36OX36OX280	14X14X11	1		
FO0614A00	1,65	3,64	36OX36OX280	14X14X11	1		
FO0602030	1,25	2,76	36OX36OX280	14X14X11	1		
FO0870010	1,70	3,74	36OX36OX280	14X14X11	1		



HOSE REELS



ACCESSORIES



MERCHANDISE



AIR



ANTIFREEZE



AdBlue®



BIO DIESEL



DIESEL



FOOD



GASOLINE



GREASE



KEROSENE



OIL



WATER



WINDSCREEN

CHART

A60 - A80 - A120

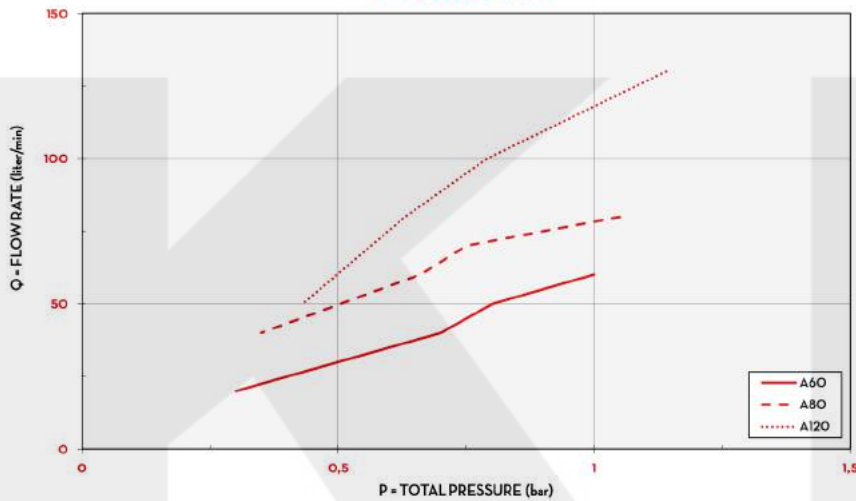

TYPE OF FLUID DIESEL
TEMPERATURE 20-25-10 °C

IN THE BOX

- A60/A80/A120 NOZZLE
- INSTRUCTION MANUAL

DETAILS



AUTOMATIC STOP



F 1" SWIVEL

DIMENSIONS

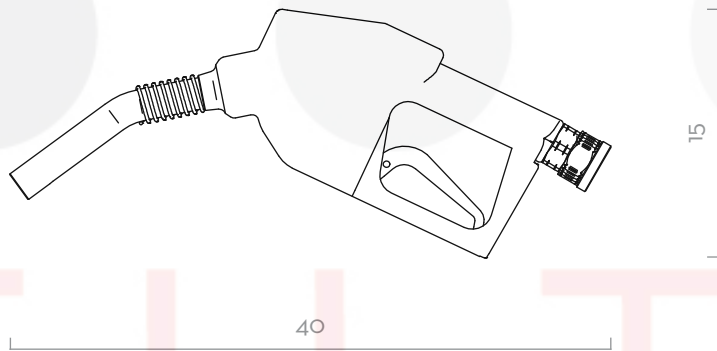

Dimensions expressed in millimeters

MATERIALS

- BODY: ALUMINIUM
- SEAL: VITON

TECHNICAL DATA

CODE	DESCRIPTION	FLUIDS TYPE	FLOW-RATE		INLET		SPOUT
			L/MIN	GPM	WITHOUT SWIVEL BSP	WITH SWIVEL BSP	EXT. Ø MM
FO0603060	A60	D G	70	19	F 3/4"	F 1"	24
FO0602020	A60 UNLEADED	D G	60	16	F 3/4"	F 1"	20
FO0604030	A80	D G	90	24	F 1"	F 1"	29
FO0610020	A120	D G	120	32	F 1"	F 1"	29
FO0613A00	A60 - EN 13012	D	70	19	F 3/4"	F 1"	24
FO0614A00	A120 - EN 13012	D	120	32	-	F 1"	29
FO0602030	AUTOMATIC NOZZLE RAPSOIL	B	60	16	F 3/4"	F 1"	24
FO0870010	A60 + K24 PLASTIC BLACK	D	70	19	-	F 1"	24

A60 / A80 / A120



DISPENSERS



PUMPS



METERS



NOZZLES



FILTRATION



FLUID
MONITORING

A280

FEATURES

- AUTOMATIC
- READY TO USE
- HEAVY DUTY CONDITIONS
- STURDY STRUCTURE

The PIUSI A280 is the biggest nozzle among the Piusi range of automatic fuel nozzles with its flow rate up to 280 l/min and spout OD 38,5 mm. Fully automatic thanks to the structural device that stops dispensing when the tank is full; it comes with a built-in swivel to guarantee maximum versatility.

PERFORMANCE

UP TO

280 L/MIN

FLOW-RATE

1 1/2" BSP

INLET

38,5MM

OD SPOUT

A280



A280



PACKAGING

CODE	WEIGHT		PACKAGING			N. BOXES / EUROPALLET	
	KG	LBS	MM	INCH	PCS/BOX	✈	🚚
F13249000	3,30	7,28	-	-	1	-	-



HOSE REELS



ACCESSORIES



MERCHANDISE



AIR



ANTIFREEZE



AdBlue®



BIODIESEL



DIESEL



FOOD



GASOLINE



GREASE



KEROSENE



OIL



WATER



WINDSCREEN

CHART

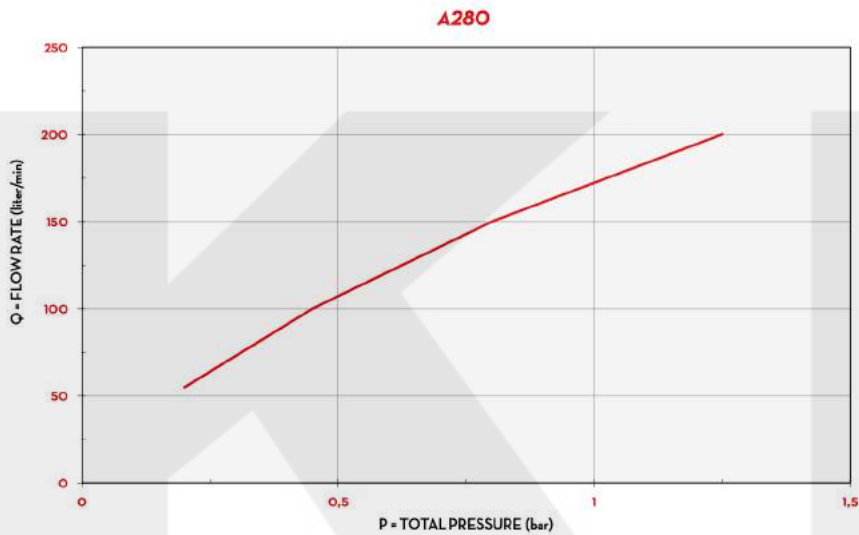

TYPE OF FLUID DIESEL

TEMPERATURE 10 °C

IN THE BOX

- A280 NOZZLE
- INSTRUCTION MANUAL

DETAILS



AUTOMATIC STOP



F 1" SWIVEL

DIMENSIONS

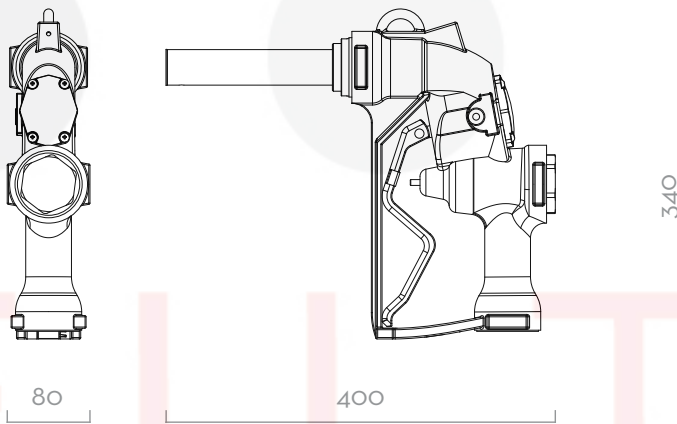

Dimensions expressed in millimeters

MATERIALS

- BODY: ALUMINIUM
- SEAL: VITON

TECHNICAL DATA

CODE	DESCRIPTION	FLUIDS TYPE	FLOW-RATE		INLET		SPOUT
			L/MIN	GPM	WITHOUT SWIVEL BSP	WITH SWIVEL BSP	EXT. Ø MM
F13249000	A280	D	280	74	-	1 1/2"	38,5

A280



DISPENSERS



PUMPS



METERS



NOZZLES



FILTRATION



FLUID MONITORING

SELF 2000 / SELF 3000

FEATURES

- MANUAL
- VERSATILE
- HIGH EFFICIENCY
- LEVER PROTECTION

The PIUSI SELF 2000 / SELF 3000 manual nozzles perform the maximum efficiency thanks to the low-flow resistance and the wide range of applications including transfer systems run by gravity. They are supplied with removable lever protection and connectors.

PERFORMANCE

UP TO

150 L/MIN

FLOW-RATE

25MM

OD SPOUT

SELF 2000 / SELF 3000



SELF 2000 DIESEL



SELF 3000 DIESEL/GASOLINE



PLASTIC NOZZLE WATER/DIESEL



PLASTIC NOZZLE WATER/FOOD



PACKAGING

CODE	WEIGHT		PACKAGING			N. BOXES / EUROPALLET	
	KG	LBS	MM	INCH	PCS/BOX		
00063900A	0,7	1,5	400X250X200	16X11X7,8	1		
00064900A	0,7	1,5	400X250X200	16X11X7,8	1		
00064902A	0,7	1,5	400X250X200	16X11X7,8	1		
00065001A	0,7	1,5	400X250X200	16X11X7,8	1		
00065600A	0,7	1,5	400X250X200	16X11X7,8	1		
FO0641120	0,7	1,5	400X250X200	16X11X7,8	1		
FO0641130	0,7	1,5	400X250X200	16X11X7,8	1		
FO065000A	0,7	1,5	400X250X200	16X11X7,8	1		
FO0650020	0,7	1,5	400X250X200	16X11X7,8	1		
FO063000A	0,3	0,7	-	-	1		



HOSE REELS



ACCESSORIES



MERCHANDISE



AIR



ANTIFREEZE



AdBlue®



BIODIESEL



DIESEL



FOOD



GASOLINE



GREASE



KEROSENE



OIL



WATER



WINDSCREEN

CHART

SELF2000/3000

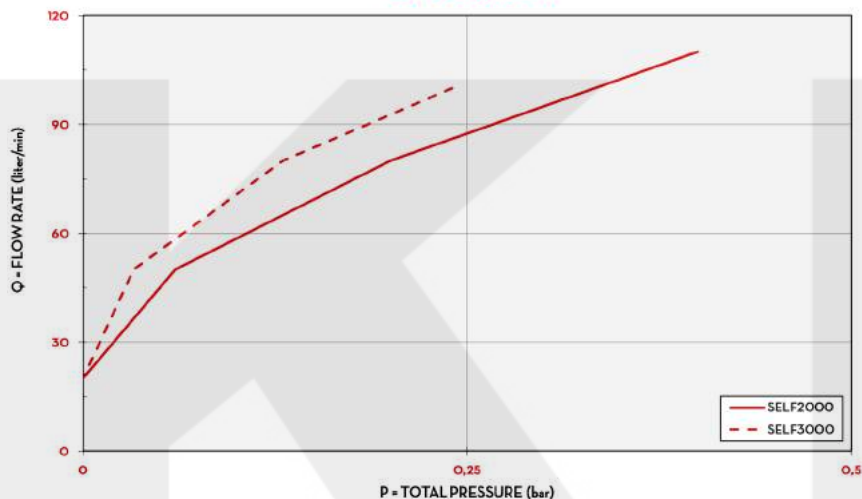

TYPE OF FLUID	DIESEL
TEMPERATURE	18 °C

IN THE BOX

- SELF 2000/ SELF 3000 NOZZLE
- INSTRUCTION MANUAL

DETAILS



LEVER PROTECTION



ROTATING SWIVEL

DIMENSIONS

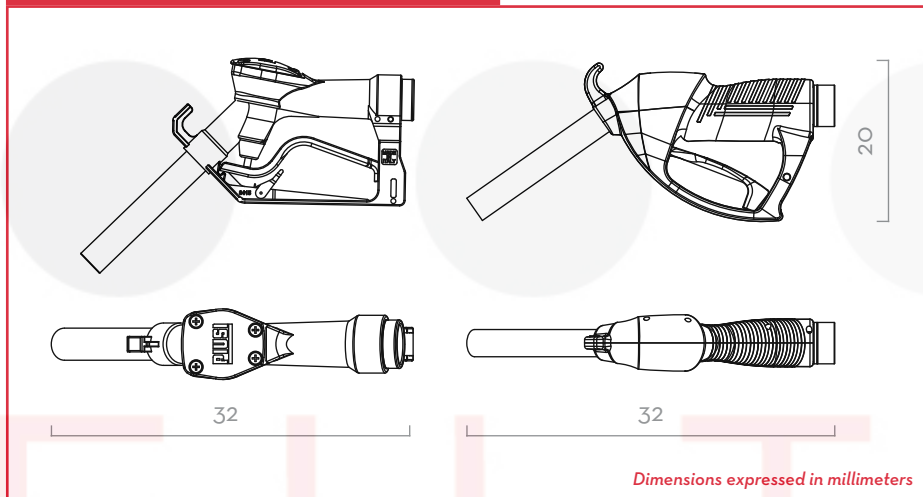

MATERIALS

- BODY: ALUMINIUM
- SEAL: VITON

TECHNICAL DATA

CODE	DESCRIPTION	FLUIDS TYPE	FLOW-RATE		INLET		SPOUT
			L/MIN	GPM	SWIVEL	Ø BSP	EXT. Ø MM
00063900A	SELF2000 1" BSP - UNLEADED SPOUT	B D G O	120	32	FEMALE	1" BSP	20
00064900A	SELF 2000 - 3/4 BSP	B D O	120	32	FEMALE	3/4" BSP	25
00064902A	SELF 2000 - 3/4 BSP - UNLEADED SPOUT	B D G O	120	32	FEMALE	3/4" BSP	20
00065001A	SELF 3000 1 UNLEADED SPOUTSELF 2000 1"	B D O	150	40	FEMALE	1" BSP	20
00065600A	SELF 2000 1"	B D O	120	32	FEMALE	1" BSP	25
FO0641120	SELF 2000 WITH HOSE TAIL	B D O	120	32	FEMALE	3/4" BSP	25
FO0641130	SELF 2000 1	B D O	120	32	FEMALE	1" BSP	25
FO065000A	SELF 3000 1	B D O	150	40	FEMALE	1" BSP	25
FO0650020	SELF 3000 1 UNLEADED SPOUT	B D G O W	150	40	FEMALE	1" BSP	20
FO063000A	PLASTIC NOZZLE-S 1" BLACK	B D O W	80	21	FEMALE	1" BSP	34

SELF 2000 / SELF 3000



W **A** **D**

F **I** **L** **T** **E** **R**

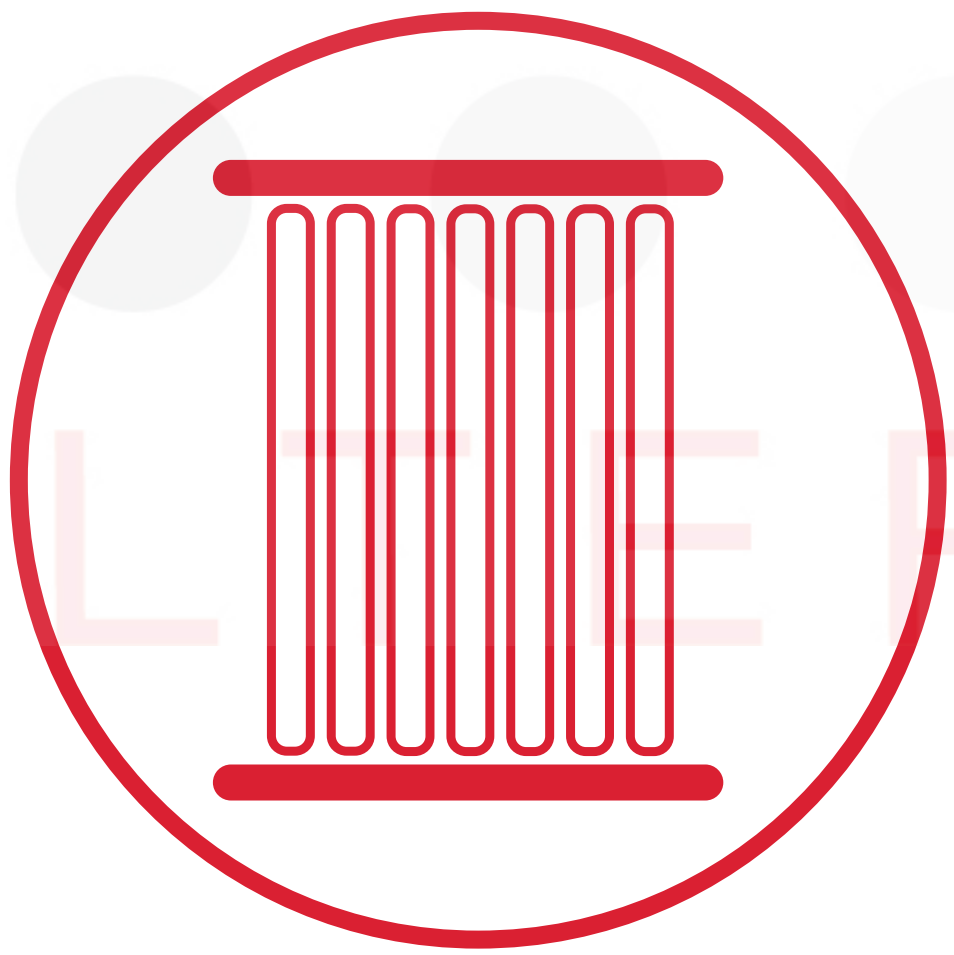

KKD

FILTRATION

FILTER





DISPENSERS



PUMPS



METERS



NOZZLE



FILTRATION

FLUID
MONITORING

FILTROLL

FEATURES

- DOUBLE-STAGE FILTRATION
- SPIRAL TUBE
- EASY TO HANDLE
- LARGE-DIAMETER WHEELS

The PIUSI FILTROLL is an innovative portable unit that provides a complete double filtering capacity of any kind of tank while absorbing water and impurities. The built-in sturdy trolley allows the operator to easily handle this device in any condition. It is equipped with suction pipe and integrated bottom valve.

PERFORMANCE

UP TO

56 L/MIN

FLOW-RATE

AC/DC

VOLTAGE

POWER

30μ

WATER ABSORPTION

FILTRING

5μ

IMPURITIES

FILTRING



FILTROLL

PACKAGING

CODE	WEIGHT		PACKAGING		
	KG	LBS	MM	INCH	PCS/BOX
FO0506000	35	77,2	790X590X590	31,1X23,2X23,2	1
FO050606A	40	88,2	790X590X590	31,1X23,2X23,2	1



HOSE REELS



ACCESSORIES



MERCHANDISE



AIR



ANTIFREEZE



AdBlue®



BIODIESEL



DIESEL



FOOD



GASOLINE



GREASE



KEROSENE



OIL



WATER



WINDSCREEN

CHART

FILTROLL

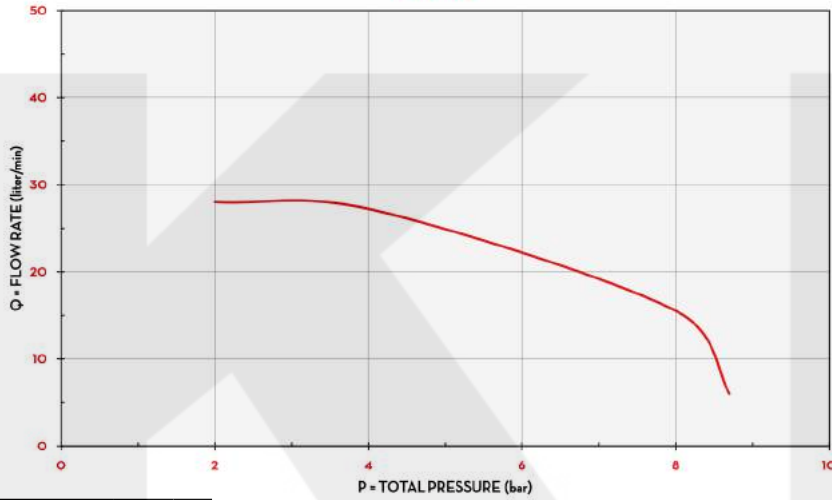

TYPE OF FLUID SAE 80W90
TEMPERATURE 17 °C

IN THE BOX

- FILTROLL UNIT
- SUCTION HOSE
- DELIVERY HOSE
- NOZZLE
- INSTRUCTION MANUAL

DETAILS



TWO-STEP FILTRATION



WATER/IMPURITIES FILTERS

DIMENSIONS

FILTROLL FRONT

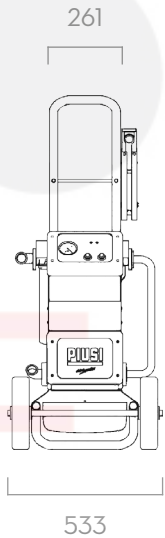

FILTROLL BACK

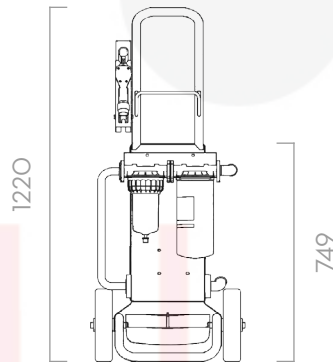

FILTROLL SIDE

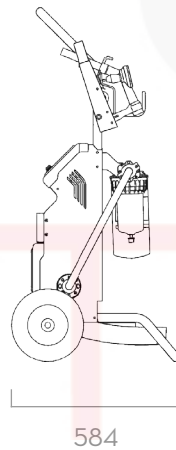

Dimensions expressed in millimeters

MATERIALS

- BODY: CAST IRON
- ROTOR: SINTERED STEEL
- VANES: TECHNOPYLIMER
- SHAFT: STEEL
- FILTER: ABSORBENT FILTERING PAPER

TECHNICAL DATA

CODE	DESCRIPTION	FLUIDS TYPE	FLOW-RATE		VOLTAGE			PUMP TYPE	HOSE LENGTH	
			L/MIN	GPM	AC V/ HZ DC VOLT	POWER WATT	AMP. MAX.		DELIVERY M/FT.	SUCTION M/FT
FO0506000	FILTROLL DIESEL	D	56	14,8	230/50-60	350/600	3/6	PANTH. 56	4 / 13,1	3 / 9,8
FO050606A	FILTROLL 12V DIESEL	D	56	14,8	12	300	35	PANTH. DC	4 / 13,1	4 / 13,1

AVAILABLE IN VERSION 230V/60HZ, 120V/60HZ



DISPENSERS



PUMPS



METERS



NOZZLE



FILTRATION

FLUID
MONITORING

WATER CAPTOR

FEATURES

- BURSTING PRESSURE 10 BAR
- REPLACEABLE CARTRIDGE
- HIGH EFFICIENCY
- SMALL SIZE

The PIUSI WATER CAPTOR is a filter that absorbs any residual water particles that may be present in the fluid. The innovative cartridge needs to be replaced when filtering capacity is reduced due to the amount of water particles already absorbed. Available both for 70 or 150 l/min flow rates, these filters are also available with 1" inch fitting.

PERFORMANCE

UP TO

150 L/MIN

FLOW-RATE

3,5 BARMAX OPERATING
PRESSURE**200β/30μ**

FILTERING CAPACITY

**WATER CAPTOR 150 L/MIN**

PACKAGING

CODE	WEIGHT	DIMENSIONS MM	PACKAGING	
	KG		CARTRIDGE PSC / BOX	FILTER HEAD PCS/BOX
WATER CAPTOR				
FO0611A00	2,4	390X285X140	2	1
FO0611A10	2,3	390X285X140	1	1
FO0611O10	9,8	420X320X250	12	-
FO0611O20	9,7	350X350X360	6	-
F14640000	-	357X357X275	-	50
F15743000	0,9	200X120X240	-	1



HOSE REELS



ACCESSORIES



MERCHANDISE



AIR



ANTIFREEZE



AdBlue®



BIODIESEL



DIESEL



FOOD



GASOLINE



GREASE



KEROSENE



OIL



WATER



WINDSCREEN

PRODUCTS



150 L/MIN WATER CAPTOR WITH WATER ABSORPTION



70 L/MIN WATER CAPTOR WITH WATER ABSORPTION

IN THE BOX

- FILTER HEAD
- WATER CAPTOR CARTRIDGE

DETAILS



FILTER HEAD



WATER CAPTOR CARTRIDGE

DIMENSIONS

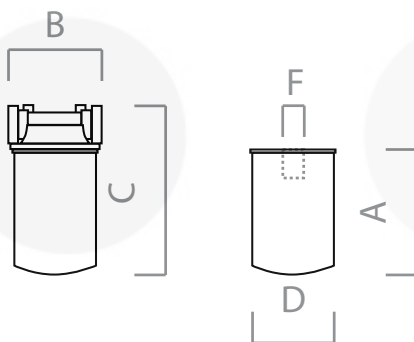

CODE	A (mm)	B (mm)	C (mm)	D (mm)	F
FOO611A00	-	100	280	95	-
FOO611A10	-	171	340	120	-
FOO611O10	220	-	-	95	1"-12 UNF
FOO611O20	275	-	-	120	1 1/2-16 UNF
F14640000	-	100	-	-	1"-12 UNF
F15743000	-	171	-	-	1 1/2-16 UNF 1 1/4 BSP

Dimensions expressed in millimeters

MATERIALS

- FILTER: ABSORBENT FILTERING PAPER

TECHNICAL DATA

CODE	DESCRIPTION	FLUIDS TYPE	FLOW-RATE		INLET / OUTLET BSP	WATER ABSORBING	EFFICIENCY β	MICRO μ m	PRESSURE BAR
			L/MIN	GPM					

WATER CAPTOR

FOO611A00	70 L/MIN GAS WITH HEAD	D G	70	18,5	1"	YES	200	30	3,5
FOO611A10	150 L/MIN GAS WITH HEAD	D G	150	39,6	1"	YES	200	30	3,5
FOO611O10	CARTRIDGE 70 L/MIN WATER SEPARATOR	D G	70	18,5	-	YES	200	30	3,5
FOO611O20	CARTRIDGE 150 L/MIN WATER SEPARATOR	D G	150	39,6	-	YES	200	30	3,5
F14640000	FILTER HEAD UNF 70 L/MIN	D G	-	-	1"	NO	-	-	-
F15743000	FILTER HEAD 100 L/MIN	D G	-	-	1"	NO	-	-	-

WATER CAPTOR



DISPENSERS



PUMPS



METERS



NOZZLE



FILTRATION

FLUID
MONITORING

CLEAR CAPTOR

FEATURES

- REPLACEABLE CARTRIDGE
- HIGH EFFICIENCY
- SMALL SIZE

The PIUSI CLEAR CAPTOR is a range of cartridge filters that can be applied both on suction or delivery flow directions. They are equipped with a high-performance cartridge and a plastic container to collect all eventual impurities or water particles that may be present in the fluid. Thanks to the valve at the bottom of the container, it is possible to remove contaminations quickly and safely to ensure the maximum possible filter life.

PERFORMANCE

UP TO

150 L/MIN

FLOW-RATE

5 BAR

MAX OPERATING

PRESSURE

2β/5μ

FILTERING CAPACITY



**CLEAR CAPTOR WATER FILTER
WITH WATER ABSORPTION**



PACKAGING

CODE	WEIGHT	PACKAGING		
	KG	DIMENSIONS MM	CARTRIDGE PSC / BOX	FILTER HEAD PCS/BOX

CLEAR CAPTOR

FOO611B00	2,3	390X285X140	2	1
FOO611B10	2,0	390X285X140	2	1
FOO611B60	2,3	390X285X140	1	1
FOO611O30	1,9	190X190X240	6	-
FOO611O40	1,2	190X190X240	6	-
FOO611O60	0,2	190X190X240	1	1
F15744000	1,0	200X120X240	-	1



HOSE REELS



ACCESSORIES



MERCHANDISE



AIR



ANTIFREEZE

AdBlue[®]

BIODIESEL



DIESEL



FOOD



GASOLINE



GREASE



KEROSENE



OIL



WATER



WINDSCREEN

PRODUCTS**CLEAR CAPTOR WATER FILTER WITH WATER ABSORPTION****CLEAR CAPTOR FILTER****CLEAR CAPTOR STRAINER****IN THE BOX**

- FILTER CARTRIDGE
- METALLIC HEAD
- ADDITIONAL CARTRIDGE
- INSTRUCTION MANUAL

DETAILS

STRAINER CARTRIDGE



IMPURITIES PAPER CARTRIDGE



WATER PAPER CARTRIDGE

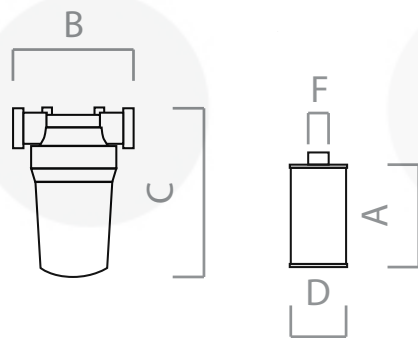

DRAIN VALVE

DIMENSIONS*Dimensions expressed in millimeters*

CODE A B C D F
(mm) (mm) (mm) (mm)

CODE	A (mm)	B (mm)	C (mm)	D (mm)	F
FOO611B00	-	171	270	-	-
FOO611B10	-	171	270	-	-
FOO611B60	-	171	270	-	-
FOO611O30	110	-	-	75	1" BSP M
FOO611O40	155	-	-	75	1" BSP M
FOO611O60	110	-	-	75	1" BSP M
F15744000	-	171	-	-	1" BSP F

MATERIALS

- FILTER: ABSORBENT FILTERING PAPER

TECHNICAL DATA

CODE	DESCRIPTION	FLUIDS TYPE	FLOW-RATE		INLET / OUTLET BSP	WATER ABSORBING	EFFICIENCY β	MICRO μ m	PRESSURE BAR
			L/MIN	GPM					

CLEAR CAPTOR

FOO611B00	CLEAR CAPTOR FILTER	B D G	100	26,4	1"	NO	2	5	5
FOO611B10	CLEAR CAPTOR WATER FILTER	B D G	70	18,5	1"	YES	200	30	5
FOO611B60	CLEAR CAPTOR STRAINER	B D G	100	26,4	1"	NO	2	125	5
FOO611O30	CLEAR CAPTOR CARTRIDGE	B D G	100	26,4	-	NO	2	5	-
FOO611O40	CLEAR CAPTOR WATER FILTER CARTRIDGE	B D G	70	18,5	-	YES	200	30	-
FOO611O60	CLEAR CAPTOR STRAINER CARTRIDGE	B D G	100	26,4	-	NO	2	125	-
F15744000	FILTER HEAD CLEAR CAPTOR	B D G	-	-	1"	NO	-	-	-

CLEAR CAPTOR



DISPENSERS



PUMPS



METERS



NOZZLE



FILTRATION

FLUID
MONITORING

FUEL & BIOFUEL

FEATURES

- BURSTING PRESSURE 10 BAR
- REPLACEABLE CARTRIDGE
- HIGH EFFICIENCY
- SMALL SIZE

Among its range of filters, PIUSI has developed the FUEL&BIOFUEL FILTER: cartridge and water absorbing filters that prevent fluid contamination thanks to their improved filtration capacity up to 30µ.

PERFORMANCE

UP TO

100 L/MIN

FLOW-RATE

3,5 BAR

MAX OPERATING

PRESSURE

FILTRING CAPACITY

200β/10µ

BIOFUEL

FILTRING CAPACITY

2β/5-10µ

FUEL



BIO-FUEL FILTER



OIL AND FUEL FILTER



LINE FILTER 1-1



PACKAGING

CODE	WEIGHT	DIMENSIONS MM	PACKAGING	
	KG		CARTRIDGE PSC / BOX	FILTER HEAD PCS/BOX

FILTER FOR BIOFUEL

FO0611COO	2	390X285X140	2	1
FO0611C10	1,9	390X285X140	1	1
F14861000	-	-	1	-
R14862000	-	-	1	-
F14640000	-	-	-	50
F15743000	-	-	-	1

FILTER FOR FUEL AND OIL

FO77200A	1	200X120X140	1	1
FO914900A	2,6	390X285X140	1	1
FO9149020	2,6	390X285X140	1	1
FO0611000	-	-	1	-
FO9359000	-	-	1	-
FO9359010	-	-	1	-
F14528000	-	-	-	1
F15743000	-	-	-	1
F16483010	9,2	500X300X200	15	-

LINE FILTER

FO8950000	-	-	-	-
-----------	---	---	---	---



HOSE REELS



ACCESSORIES



MERCHANDISE



AIR



ANTIFREEZE



AdBlue®



BIODIESEL



DIESEL



FOOD



GASOLINE



GREASE



KEROSENE



OIL



WATER



WINDSCREEN

DIMENSIONS

A B C D F
(mm) (mm) (mm) (mm)

FILTER FOR BIOFUEL

FO0611C00	-	100	275	95	-
FO0611C10	-	171	340	130	-
F14861000	220	-	-	95	1" - 12 UNF
R14862000	275	-	-	130	1" 1/2 - 16 UNF
F14640000	-	100	-	-	1" - 12 UNF
F15743000	-	171	-	-	1" 1/2 - 16 UNF 1" 1/4 BSP

FILTER FOR FUEL AND OIL

FO777200A	-	100	160	98	-
FO914900A	-	171	236	132	-
FO9149020	-	171	236	132	-
FO0611000	145	-	-	98	3/4" BSP
FO9359000	180	-	-	132	1" 1/4 BSP
FO9359010	180	-	-	132	1" 1/4 BSP
F14528000	-	100	-	-	3/4" BSP
F15743000	-	171	-	-	1" 1/2 - 16 UNF 1" 1/4 BSP
F16483010	139	-	-	93	3/4" BSP

LINE FILTER

FO8950000	-	-	-	-	-
-----------	---	---	---	---	---

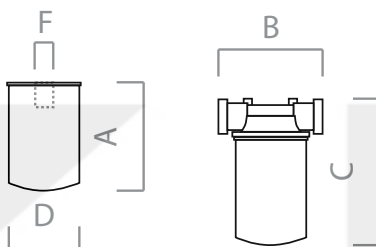
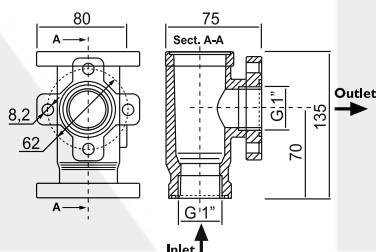
**BIO-FUEL / OIL AND FUEL FILTERS****LINE FILTER 1-1**

Dimensions expressed in millimeters

IN THE BOX

- FILTER CARTRIDGE
- METALLIC HEAD
- ADDITIONAL CARTRIDGE
- INSTRUCTION MANUAL

DETAILS

FILTER HEAD



REPLACEABLE CARTRIDGE



MESH STRAINER



LINE FILTER

MATERIALS

- FILTER CARTRIDGE
- METALLIC HEAD
- ADDITIONAL CARTRIDGE
- INSTRUCTION MANUAL

TECHNICAL DATA

CODE	DESCRIPTION	FLUIDS TYPE	FLOW-RATE		INLET / OUTLET	WATER ABSORBING	EFFICIENCY	MICRO	PRESSURE
			L/MIN	GPM					

FILTER FOR BIOFUEL

FO0611C00	BIO-FUEL FILTER 70 L/MIN 1"X1"	B G	70	18,5	1"	YES	200	10	3,5
FO0611C10	BIO-FUEL FILTER 100 L/MIN 1"X1"	B G	100	26,4	1"	YES	200	10	3,5
F14861000	CARTRIDGE 70 L/MIN BIO-FUEL	B G	70	19,5	-	YES	200	10	3,5
R14862000	CARTRIDGE 100 L/MIN BIO-FUEL	B G	100	26,4	-	YES	200	10	3,5
F14640000	FILTER HEAD UNF 70 L/MIN		-	-	1"	NO	-	-	-
F15743000	FILTER HEAD 100 L/MIN		-	-	1"	NO	-	-	-

FILTER FOR FUEL AND OIL

FO777200A	60 L/MIN FILTER WITH HEAD	B D G O	60	15,9	1"	NO	2	10	12
FO914900A	100 L/MIN FILTER WITH HEAD	B D G O	100	26,4	1"	NO	2	10	12
FO9149020	100 L/MIN FILTER WITH HEAD	B D G O	100	26,4	1"	NO	2	5	12
FO0611000	CARTRIDGE 60 L/MIN	B D G O	60	15,9	-	NO	2	10	12
FO9359000	CARTRIDGE 100 L/MIN	B D G O	100	26,4	-	NO	2	10	12
FO9359010	CARTRIDGE 100 L/MIN	B D G O	100	26,4	-	NO	2	5	12
F14528000	FILTER HEAD 3/4 BSP 60 L/MIN	B D G O	-	-	1"	NO	-	-	-
F15743000	FILTER HEAD 100 L/MIN	B D G O	-	-	1"	NO	-	-	-
F16483010	PIUSI BOX CARTRIDGE 60 L/MIN (15 PCS)		60	15,9	-	NO	2	10	12

LINE FILTER

FO8950000	LINE FILTER		-	-	1"	NO	-	-	-
-----------	-------------	--	---	---	----	----	---	---	---

FUEL & BIOFUEL



DISPENSERS



PUMPS



METERS



NOZZLE



FILTRATION



FLUID
MONITORING

FOOT VALVE

FEATURES

- HEAVY DUTY
- STURDY STRUCTURE
- LOW PRESSURE DROP
- ANTI-SHOCK MATERIALS

The FOOT VALVE designed and engineered by PIUSI is a new concept of valve for fuel suction hoses on machinery. It is fitted with a mesh filter for diesel fuel residues, anti-shock materials to avoid damage caused by dropping and, thus, a low dropping pressure. The quick locking/unlocking and the clear indications of opening and closing complete its main features.

PERFORMANCE

125 μ

FILTERING CAPACITY

1"-3/4"

BPS

INLET



FOOT VALVE WITH FILTER



PACKAGING

CODE	WEIGHT		PACKAGING		
	KG	LBS	DIMENSIONS MM	INCH	PCS/BOX
FOOT VALVE WITH FILTER					
FO0609000	2,5	5,3	180X180X170	7,1X7,1X6,7	10
FO0612000	0,2	0,44	-	-	1
FI5749000	1,35	3	215X147X116	8,5X5,8X4,6	12
FO7978000	6,7	14,8	180X180X170	7,1X7,1X6,7	25
FO8153000	0,15	0,33	-	-	1
FO9170000	6,5	14,3	180X180X170	7,1X7,1X6,7	25



HOSE REELS



ACCESSORIES



MERCHANDISE



AIR



ANTIFREEZE



AdBlue®



BIODIESEL



DIESEL



FOOD



GASOLINE



GREASE



KEROSENE



OIL



WATER



WINDSCREEN

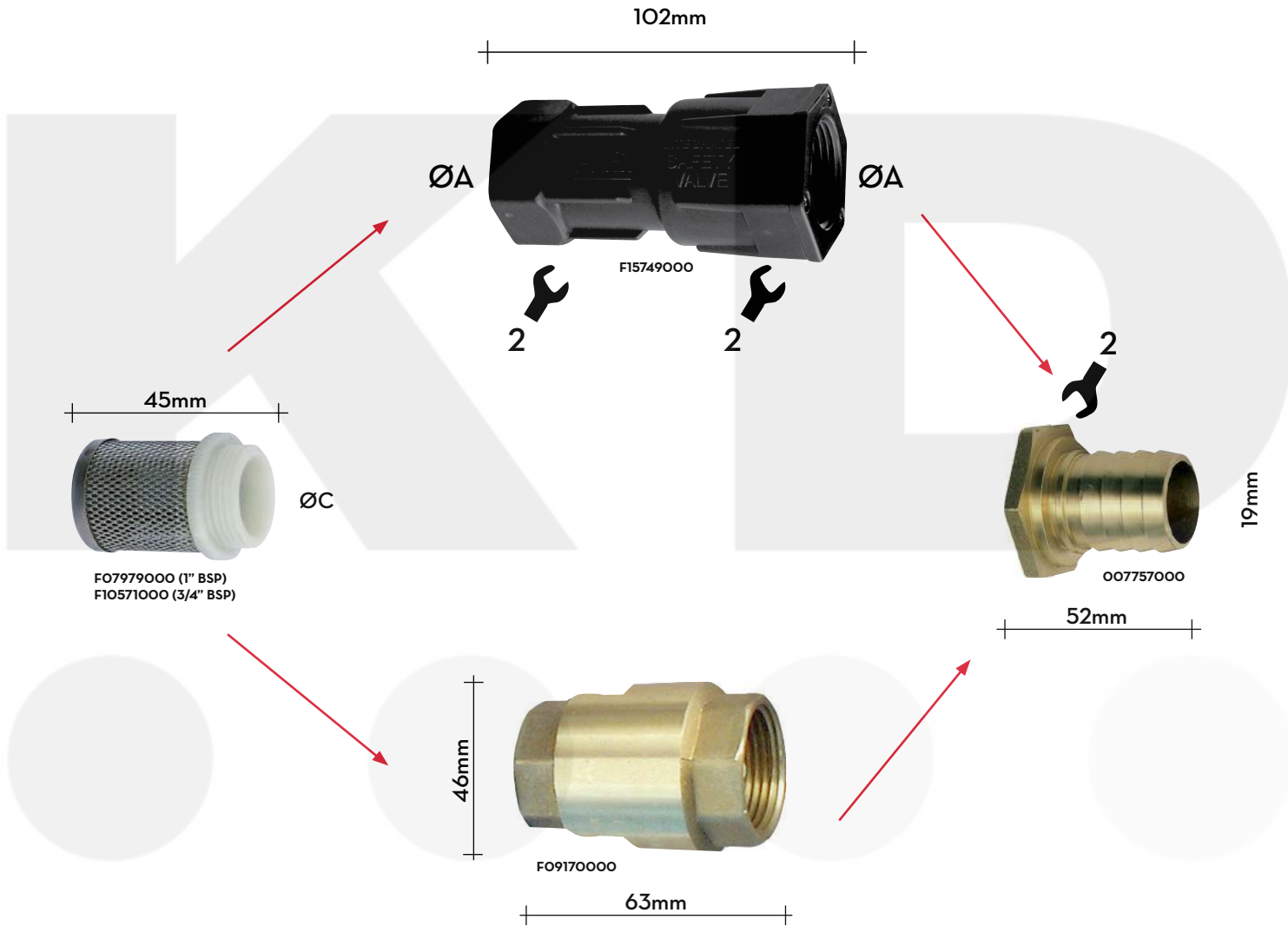

FILTER

TECHNICAL DATA

CODE	DESCRIPTION	FLUIDS TYPE	SAFETY VALVE					A	B	C	KEY		MICRO
								\varnothing BSP	\varnothing BSP	\varnothing BSP			μ m
FO0609000	1" FOOT VALVE WITH FILTER	D G O	YES	YES	-	YES	YES	-	1"	-	38	-	125
FO0612000	3/4" FOOT VALVE WITH FILTER	D G O	YES	YES	-	YES	YES	-	3/4"	-	31	-	125
F15749000	1" WITH BUILT-IN SAFETY VALVE	D G O	YES	YES	-	-	-	1"	-	-	-	42/46	-
FO7978000	1" FOOT VALVE	D O	-	-	YES	-	-	-	-	1"	-	-	-
FO8153000	3/4" FOOT VALVE	D O	-	-	YES	-	-	-	-	3/4"	-	-	-
FO9170000	HIGHER PRESSURE VALVE	D O	YES	-	YES	-	-	-	-	1"	-	-	-

FOOT VALVE WITH FILTER

FOOT VALVE



KKD

FLUID

MONITORING

FILTER





DISPENSERS



PUMPS



METERS



NOZZLE



FILTRATION



FLUID
MONITORING

OCIO

FEATURES

- LOW/HIGH LEVEL ALARMS
- FLUID MEASURES INDICATION
- BUILT-IN DISPLAY

OCIO is Piusi's tank level indicator suitable for any kind of fluid storage in tanks up to a 4 mt depth. It gives a real time indication of the fluid quantity inside the tank. It is easy to calibrate and has two alarms that can be adjusted at a specific high and low level for high and low levels.

PERFORMANCE

UP TO
4MT
HEIGHT
TANK

1%
FULL SCALE
ACCURACY

UP TO
50 MT
LENGTH
PROBE TUBE

UP TO
30 CST
VISCOSITY



OCIO

10 METERS HOSE

BRASS PROBE

PACKAGING

CODE	WEIGHT		PACKAGING		
	KG	LBS	MM	INCH	PCS/BOX
FO075510D	2,2	4,8	300X410X100	11,8X16,1X3,9	1
FO0755160	2,2	4,8	300X410X100	11,8X16,1X3,9	1



HOSE REELS



ACCESSORIES



MERCHANDISE



AIR



ANTIFREEZE



AdBlue®



BIODIESEL



DIESEL



FOOD



GASOLINE



GREASE



KEROSENE



OIL



WATER



WINDSCREEN

FUNCTIONING

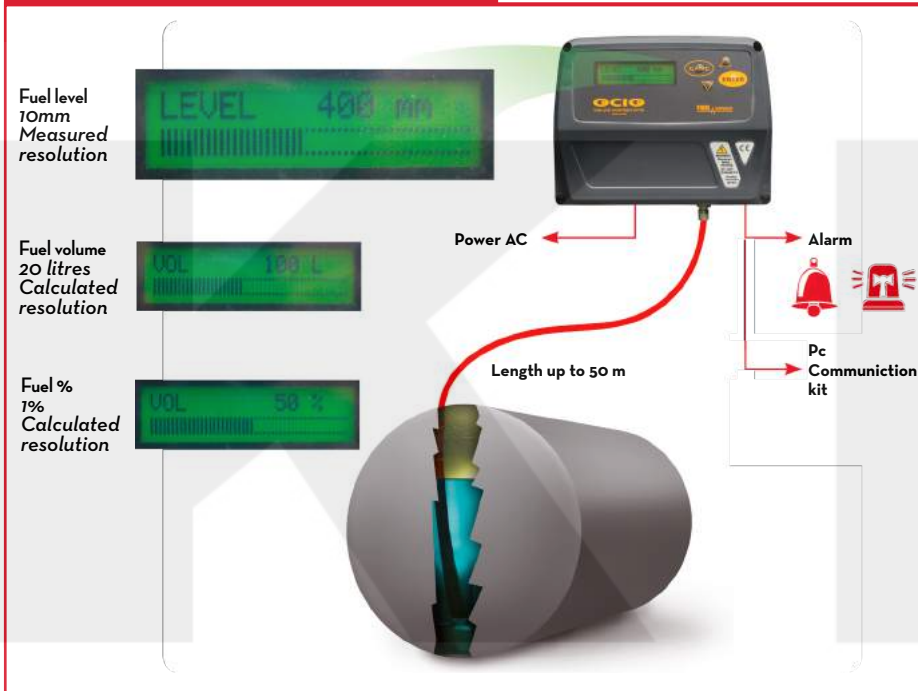

IN THE BOX

- OCIO UNIT
- PROBE
- 10 MT TUBE
- INSTRUCTION MANUAL

DETAILS



DIMENSIONS

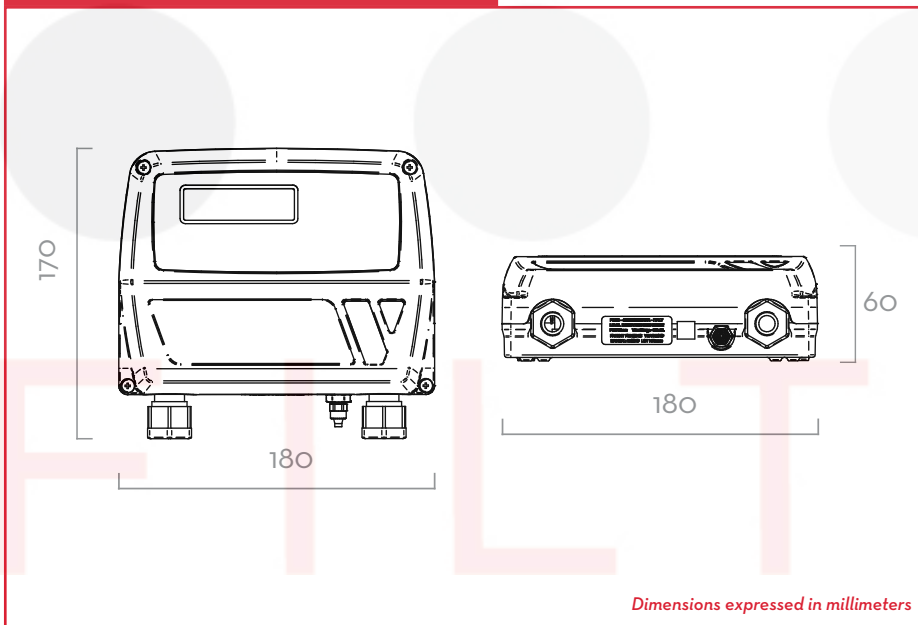

MATERIALS

- PROBE: BRASS
- TUBE: TECHNOPOLYMER

TECHNICAL DATA

CODE	DESCRIPTION	FLUIDS TYPE	VISCOSITY	VOLTAGE		RS EXIT
			cSt	AC V/Hz	POWER WATT	
FO075510D	LEVEL INDICATOR OCIO LV / RS OUTPUT	A B D O W W	UP TO 30	230/50	20	AVAILABLE
FO075516O	LEVEL INDICATOR OCIO LV / 4/20 mA OUTPUT	A B D O W W	UP TO 30	230/50	20	AVAILABLE



DISPENSERS



PUMPS



METERS



NOZZLE



FILTRATION



FLUID
MONITORING

OCIO 2.0

FEATURES

- **LOW/HIGH LEVEL ALARMS**
- **FLUID QUANTITY INDICATION**
- **FLUID HEIGHT INDICATION**
- **BUILT-IN DISPLAY**
- **COMPATIBLE WITH SSM 2.0 AND MCO 2.0**

With its brand-new design, OCIO 2.0 by Piusi is the upgraded version of the tank level indicator compatible with SSM 2.0 and MCO 2.0 systems. It requires a LAN/Wi-Fi connection to communicate with the software. It maintains all the performances of the standard OCIO. Thanks to its interchangeable probe, OCIO 2.0 is compatible with several fluids.

PERFORMANCE

UP TO

4MT

HEIGHT

TANK

1%

FULL SCALE

ACCURACY

UP TO

50 MT

LENGTH

PROBE TUBE

UP TO

30 CST

VISCOSITY



OCIO

10 METERS HOSE

BRASS PROBE



PACKAGING

CODE	WEIGHT		PACKAGING		
	KG	LBS	MM	INCH	PCS/BOX
FO0755260	2,2	4,8	300X410X100	11,8X16,1X3,9	1
FO0755220	2,2	4,8	300X410X100	11,8X16,1X3,9	1
FO075521A	2,2	4,8	300X410X100	11,8X16,1X3,9	1



HOSE REELS



ACCESSORIES



MERCHANDISE



AIR



ANTIFREEZE



AdBlue®



BIODIESEL



DIESEL



FOOD



GASOLINE



GREASE



KEROSENE



OIL



WATER



WINDSCREEN

CONNECTION



IN THE BOX

- OCIO UNIT
- PROBE
- 10 MT TUBE
- INSTRUCTION MANUAL

DETAILS



MATERIALS

- PROBE: BRASS
- TUBE: TECHNOLYMER

FUNCTIONING

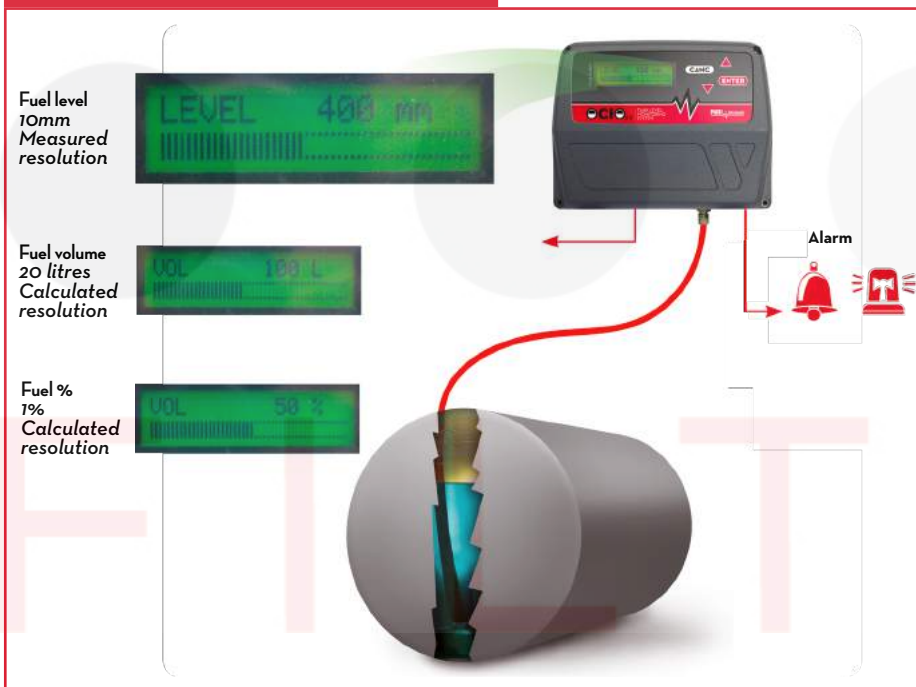

TECHNICAL DATA

CODE	DESCRIPTION	FLUIDS TYPE	VISCOSITY cSt	VOLTAGE		RS EXIT
				AC V./HZ	POWER WATT	
FO0755260	LEVEL INDICATOR OCIO MC 2.0	A B D O W	UP TO 30	230-50/60	20	REQUIRED
FO0755220	LEVEL INDICATOR OCIO RS485 2.0	A B D O W	UP TO 30	230-50/60	20	REQUIRED
FO075521A	LEVEL INDICATOR OCIO WIFI 2.0	A B D O W	UP TO 30	230-50/60	20	REQUIRED



DISPENSERS



PUMPS



METERS



NOZZLE



FILTRATION



FLUID
MONITORING

ACCESS85

FEATURES

- ACCESS CONTROL
- SUITABLE FOR ANY PUMP AND SYSTEM
- READY TO USE
- MULTI USERS
- LEVEL CONTROL INPUT

The PIUSI ACCESS85 is an electronic control unit that allows users to control the withdrawal of fuel from a tank by several users. It controls pump start/stop, user access thanks to the user electronic keys, the position of dispensing nozzle. It also features a built-in emergency button to stop all operations.

PERFORMANCE

UP TO

85

USERS

AC

CONTINUOUS DUTY

POWER



ACCESS85



PACKAGING

CODE	WEIGHT		PACKAGING		
	KG	LBS	MM	INCH	PCS/BOX
FO0702000	0,7	1,5	120X140X200	4,7X5,5X7,9	1
FO0702010	0,7	1,5	120X140X200	4,7X5,5X7,9	1



HOSE REELS



ACCESSORIES



MERCHANDISE



AIR



ANTIFREEZE



AdBlue®



BIODIESEL



DIESEL



FOOD



GASOLINE



GREASE



KEROSENE



OIL



WATER



WINDSCREEN

FUNCTIONING



IN THE BOX

- ACCESS85 UNIT
- INSTRUCTION MANUAL

TECHNICAL DATA

CODE	DESCRIPTION	FLUIDS TYPE	USERS	USERS KEY	VOLTAGE		
					AC V./HZ	POWER WATT	AMP. MAX.
FO0702000	ACCESS 85	D G K O	85	NO	230	3,5	6
FO0702010	KIT ACCESS 85	D G K O	85	4	230	3,5	6



DISPENSERS



PUMPS



METERS



NOZZLE



FILTRATION



FLUID
MONITORING

MC BOX

FEATURES

- ACCESS CONTROL
- SUITABLE FOR ANY PUMP
- PULSE METER INPUT
- MULTI USERS
- COMPATIBLE WITH SSM2018 SOFTWARE

The PIUSI MC BOX is a multi-user control panel that allows pump management, authorized user access, pre-set dispensing and pulse meter input. Thanks to these features, each site can enter the Fuel Management System universe.

Do you already have a pump, a pulse flow meter, or both? With Piusi MC BOX you can create your custom electronic dispenser, suitable for any fluid and perfectly compatible with Piusi's FMS SSM 2018.

PERFORMANCE

UP TO
120

USERS

AC/DC

VOLTAGE
POWER

UP TO
255

TRANSACTION MEMORY



MC BOX



PACKAGING

CODE	WEIGHT		PACKAGING		
	KG	LBS	MM	INCH	PCS/BOX
F1398000C	5	19,4	480X370X265	18,9X14,6X10,4	1
F1398005B	5	19,4	480X370X265	18,9X14,6X10,4	1
F1398001B	6	13,2	480X370X265	18,9X14,6X10,4	1
F1398002B	6	13,2	480X370X265	18,9X14,6X10,4	1



HOSE REELS



ACCESSORIES



MERCHANDISE



AIR



ANTIFREEZE



AdBlue®



BIODIESEL



DIESEL



FOOD



GASOLINE



GREASE



KEROSENE



OIL



WATER



WINDSCREEN

CONNECTION SCHEME



IN THE BOX

- MCBOX UNIT
- INSTRUCTION MANUAL

DETAILS



EASY ACCESS TO CONNECTION



DISPLAY COVER

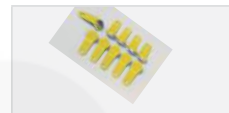

USER KEY

DIMENSIONS

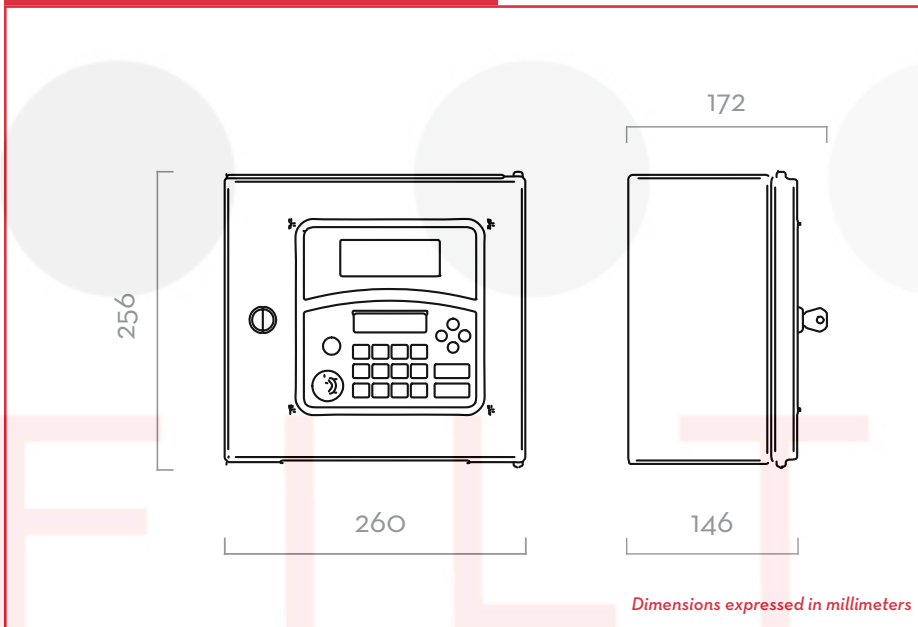

TECHNICAL DATA

CODE	DESCRIPTION	FLUIDS TYPE	USERS	VOLTAGE			METERS
				AC V/HZ	POWER WATT	AMP. MAX. (load motor)	
F139800OC	MC BOX (ANY FLUIDS)	D G K O	80	230/50	35	6,5	-
F1398005B	MC BOX (ANY FLUIDS)	D G K O	120	230/50	35	6,5	-
F1398001B	MC BOX 12V	D G K O	120	12	10	50	-
F1398002B	MC BOX 24V	D G K O	120	24	10	25	-

*COMPLETE BY: CD ROM WITH SOFTWARE, 10 IBUTTON USER KEY, 1 IBUTTON MANAGER KEY, USB PLUG IBUTTON KEY READER FOR PC



DISPENSERS



PUMPS



METERS



NOZZLE



FILTRATION



FLUID
MONITORING

MC BOX 2.0

FEATURES

- FLEET MANAGEMENT
- SUITABLE FOR ANY PUMP
- PULSE METER INPUT
- LAN/WI-FI VERSION AVAILABLE
- SSM2.0 SOFTWARE REQUIRED

The PIUSI MC BOX 2.0 is the evolution of the MC BOX system thanks to the integration with the 2.0 features: fuel and AdBlue® consumption monitoring and reporting, fleet management, vehicles and users control. It is suitable to manage and control an existing pump, pulse meter and nozzle.

PERFORMANCE

UP TO
1000

USERS&VEHICLES

AC
VOLTAGE

POWER



MC BOX 2.0



PACKAGING

CODE	WEIGHT		PACKAGING		
	KG	LBS	MM	INCH	PCS/BOX
FO059701A	9	19,4	480X370X265	18,9X14,6X10,4	1
FO059702A	5	19,4	480X370X265	18,9X14,6X10,4	1



HOSE REELS



ACCESSORIES



MERCHANDISE



AIR



ANTIFREEZE



AdBlue®



BIODIESEL



DIESEL



FOOD



GASOLINE



GREASE



KEROSENE



OIL



WATER



WINDSCREEN

CONNECTION SCHEME



IN THE BOX

- MCBOX UNIT
- LAN/WI-FI ADAPTER
- INSTRUCTION MANUAL

DETAILS



EASY ACCESS TO CONNECTION



DISPLAY COVER



USER&VEHICLE KEY



SSM 2.0 SW

DIMENSIONS

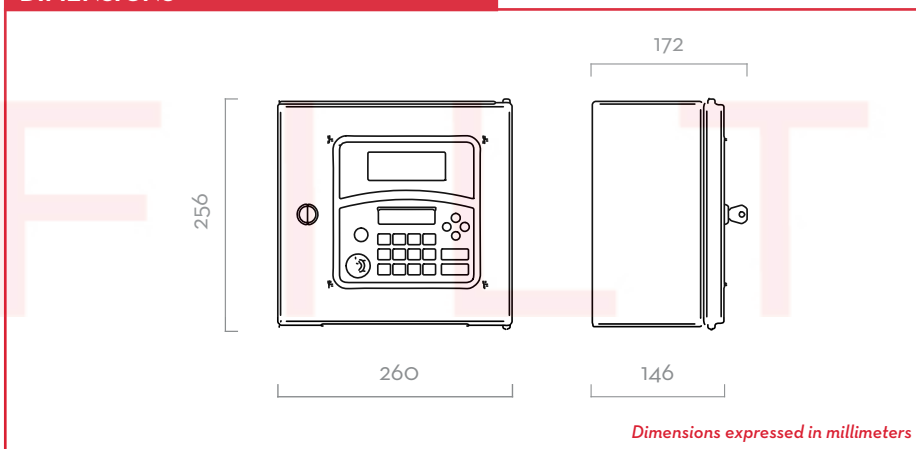

TECHNICAL DATA

CODE	DESCRIPTION	FLUIDS TYPE	VOLTAGE			SELF SERVICE MANAGEMENT 2.0
			AC V/HZ	POWER WATT	AMP. MAX. (load motor)	
FO059701A	MC BOX LAN 2.0	D O	230/50	35	6,5	REQUIRED
FO059702A	MC BOX WIFI 2.0	D O	230/50	35	6,5	REQUIRED



DISPENSERS



PUMPS



METERS



NOZZLE



FILTRATION



FLUID
MONITORING

SSM2018

FEATURES

- **USERS MANAGEMENT**
- **EASY TO INSTALL**
- **TRANSACTION REPORT**

The new Self Service Management 2018 interface answers once more to the needs you've always had. But better. More intuitively, definitely more attractively and more flexibly. What PIUSI offers you is the possibility to continue working with the Self Service Management 1.0 range, but giving you more potential and more efficiency.

PERFORMANCE

UP TO

16

DISPENSERS

USB/WEB

SOFTWARE VERSION

INSTALLATION

SOFTWARE ACTIVATION MODE



**USB
HARDWARE KEY**
without internet
connection



**WEB
EDITION**
internet connection
required

 **SELFSERVICE[®]**
MANAGEMENT
2018



1

2

3



HOSE REELS



ACCESSORIES



MERCHANDISE



AIR



ANTIFREEZE



AdBlue®



BIODIESEL



DIESEL



FOOD



GASOLINE



GREASE



KEROSENE



OIL



WATER



WINDSCREEN



The software min. requirements are:

- Monitor resolution 1280·700
- CPU: Intel® Pentium® 4 or AMD Athlon® 64 processor (2 GHz or higher)
- RAM: 2 GB
- Free space on Hard Disk: 20 GB
- Operating system: Windows VISTA SP2, Windows 7 SP1, Windows 8, Windows 8.1, Windows 10
- Database: Microsoft SQL 2012 R2 SP2 Express (included in the installation)



TECHNICAL DATA

CODE	DESCRIPTION
FO0773010	SELF SERVICE MANAGEMENT 2018 - USB
FO0773210	SELF SERVICE MANAGEMENT 2018 - WEB



DISPENSERS



PUMPS



METERS



NOZZLE



FILTRATION



FLUID
MONITORING

DATA TRANSFER SSM2018

Data transfer SSM 2018 is a set of different solutions that allow the download of transactions from the dispensers to the Self Service Management 2018 software. The great variety of the offer is based on the technology required.

Manual download

The easiest way to download the information is through the Manager key 2018, it is enough to touch the dispenser with the key to transfer all the transactions and download them on the software.

Local network

Use the local network Lan/WiFi to download data from the dispenser to your pc. By choosing between the PW-LAN or PW-WiFi it is possible to set up a connection that lets you receive all the transactions in real time.

Mobile network

Thanks to the new PW MOBILE 4G 2018 it's now possible to install all the dispensers anywhere in the world with just the need of a mobile network coverage, avoiding all the local network configurations. The equipment is provided with a worldwide SIM card which makes the PWMOBILE 4G 2018 ready to use.



PW14 / RS 485



MANAGER KEY



PW-LAN



PW-WIFI



PW MOBILE





HOSE REELS



ACCESSORIES



MERCHANDISE



AIR



ANTIFREEZE



AdBlue®



BIODIESEL



DIESEL



FOOD



GASOLINE



GREASE



KEROSENE



OIL



WATER



WINDSCREEN

PW14 / RS 485



Connection via RS485 cable with USB converter.

KEY READER AND MANAGER KEY



PW LAN



A device that allows to convert the RS485 signal to LAN, through a simple and intuitive interface.

PW WI-FI



A device that allows to convert the RS485 signal to Wi-Fi, through a simple and intuitive interface.

PW MOBILE



A new communication system that allows you to transfer data using mobile 4G network.

TECHNICAL DATA

CODE	DESCRIPTION
F13292000	PW14
F1226201A	KIT KEY READER
F1249600A	MANAGER KEY (RED)
F1271005A	PW-LAN
F1271004B	PW-WIFI
F12710150	PW MOBILE 4G 2018
F1271009A	PWSTATION-WIFI (HOTSPOT AND REPEATER IN CASE OF LONG DISTANCE)



DISPENSERS



PUMPS



METERS



NOZZLE



FILTRATION



FLUID
MONITORING

SSM2.0

FEATURES

- TANK WATCHDOG
- DRIVERS/VEHICLES MANAGEMENT
- REPORT
- SSM 2.0 CLOUD READY
- FLUID INVENTORY VALUE

The new Self Service Management 2.0 software is the most advanced response for management and monitoring of refueling, allowing supervision of drivers, vehicles and fuel tanks. Setting up the system and getting to work has never been easier: simply connect the devices to your LAN or Wi-Fi network and click on the "Detect System" button on your PC. Self Service Management 2.0 will handle the rest. The use of the Self Service Management 2.0 software requires the new range of SELF SERVICE 2.0 dispensing devices. The ibutton key reader kit is available on request.

PERFORMANCE

UP TO
1000

DIVERS / VEHICLES

USB/WEB

SOFTWARE VERSION
INSTALLATION

UP TO
20

DISPENSERS

SOFTWARE ACTIVATION MODE



**USB
HARDWARE KEY**
without internet
connection



**WEB
EDITION**
internet connection
required





HOSE REELS



ACCESSORIES



MERCHANDISE



AIR



ANTIFREEZE



AdBlue®



BIODIESEL



DIESEL



FOOD



GASOLINE



GREASE



KEROSENE



OIL



WATER



WINDSCREEN

the cost of the consumption for every distance



The system min. requirements are:

- Monitor resolution 1280x700
- CPU: Intel® Pentium® 4 or AMD Athlon® 64 processor (2 GHz or higher)
- RAM: 2 GB
- Free space on Hard Disk: 20 GB
- Operating system: Windows VISTA SP2, Windows Server 2008 R2 SP1, Windows 7 SP1, Windows 8, Windows 8.1, Windows Server 2012, Windows Server 2012 R2, Windows 10
- Database: Microsoft SQL 2012 R2 SP2 Express (included in the installation)



TECHNICAL DATA - USB CODE

CODE	DESCRIPTION
FO0772050	SSM 2.0 ENTRY
FO077202A	SSM 2.0 ADVANCED
FO077204A	SSM 2.0 SUITE
FO0772000	SSM 2.0 CLIENT*

TECHNICAL DATA - WEB CODE

CODE	DESCRIPTION
FO0772250	SSM 2.0 ENTRY - WEB EDITION
FO077222A	SSM 2.0 ADVANCED - WEB EDITION
FO077224A	SSM 2.0 SUITE - WEB EDITION
FO0772200	SSM 2.0 CLIENT* - WEB EDITION

* THE PURCHASE OF ADDITIONAL CLIENT LICENSES ENABLES YOU TO USE THE VARIOUS VERSIONS OF SELF SERVICE MANAGEMENT 2.0 ON MULTIPLE WORKSTATIONS.



DISPENSERS



PUMPS



METERS



NOZZLE



FILTRATION



FLUID
MONITORING

DATA TRANSFER SSM2.0

Among the equipment related to SSM 2.0, PIUSI has developed a set of solutions able to connect the electronic/mechanical devices to the fluid control system, which is the software that organizes the operation of the hardware; in this case Self Service Management 2.0. How does data transfer with SSM2.0 work? It depends on the technology required.

Direct downloading

Use your Manager Key to transfer the data from dispenser to PC: it is enough to touch the dispenser with the key and then use the key reader to transfer the data collected.

LAN/Wi-Fi

The way to receive in real time all information regarding the transactions: using PWLAN or PWWiFi the software recognizes the fuel dispensers that will automatically send the information to the data to the Self Service Management 2.0 software.

Mobile Network

The brand new PW MOBILE 4G 2.0 allows to install the dispenser wherever desired, even in the most remote areas, without the need of a local network: the device uses the mobile 4G (or 3G) technology to communicate and transfer data and comes with a SIM card included.



PW MOBILE

remote, everywhere



MANAGER KEY

the easiest



LAN

the standard



PW-WIFI 2.0

wireless





HOSE REELS



ACCESSORIES



MERCHANDISE



AIR



ANTIFREEZE



AdBlue®



BIODIESEL



DIESEL



FOOD



GASOLINE



GREASE



KEROSENE



OIL



WATER



WINDSCREEN

PW MOBILE



A new communication system that allows you to transfer data using mobile 4G network.

KEY READER AND MANAGER KEY 2.0



LAN



A network card that allows the RS485 signal to be converted for connection to a LAN, through a simple and intuitive interface.

PW WI-FI



A Wi-Fi network card that allows the RS485 signal to be converted for connection to an existing Wi-Fi network.

TECHNICAL DATA

CODE	DESCRIPTION
F1226201A	KIT KEY READER SELF SERVICE 2.0
F20552010	MANAGER KEY 2.0 (GREY)
F1271012A	PW WI-FI 2.0
F12710130	PW MOBILE 4G 2.0
F1271009A	PWSTATION-WIFI (HOTSPOT AND REPEATER IN CASE OF LONG DISTANCE)

DATA TRANSFER SSM2.0



FLUID MONITORING ACCESSORIES

ACCESS CONTROL

ACCESS85	CODE	DESCRIPTION
	F1590400A	USER KEY YELLOW (10PCS)
	R1623900A	NOZZLE SWITCH CONTROL
	F1249600A	MANAGER KEY 2018
	F17121000	LEVEL CONTROL



OCIO/OCIO 2.0

OCIO	CODE	DESCRIPTION
	F15611000	STAINLESS STEEL PROBE
	F12939000	OIL KIT



MC BOX

MC BOX	CODE	DESCRIPTION
	F1270800C	BLACK PEDESTAL
	F1590400A	USER KEY YELLOW (10PCS)
	R1623900A	NOZZLE SWITCH CONTROL
	F17121000	LEVEL CONTROL FOR ACCESS 85
	F1249600A	MANAGER KEY 2018



MC BOX 2.0	CODE	DESCRIPTION
	F1270800C	BLACK PEDESTAL
	F17299000	VEHICLE KEY BLUE (10PCS)
	F1590400A	USER KEY YELLOW (10PCS)
	F17121000	LEVEL CONTROL FOR ACCESS 85







HOSE REELS

FILTE R



DISPENSERS



PUMPS



METERS



NOZZLE



FILTRATION

FLUID
MONITORING

DIESEL HOSE REEL

FEATURES

- STURDY STRUCTURE
- HAND PROTECTION
- CORROSION RESISTANCE
- REDUCED PRESSURE LOSS
- HEAVY DUTY CONDITIONS

Piusi Automatic hose reels for diesel have been designed to ensure high efficiency. The sturdy structure can guarantee the best performance also in heavy duty conditions.

PERFORMANCE

UP TO

15 BARMAX OPERATING
PRESSURE

MAX

20 MTLENGTH
HOSE BOUND

AUTOMATIC HOSE REEL WITH HOSE



HOSE DIESEL HOSE REEL FOR 12M HOSE VERSION



PACKAGING

CODE	WEIGHT		PACKAGING			N. BOXES / EUROPALET	
	KG	LBS	MM	INCH	PCS/BOX	✈	🚚
WITHOUT HOSE							
FO075000A	19	41,9	550X260X540	-	1	12	20
FO075001A	18	39,7	550X260X540	-	1	12	20
FO075008A	15	33,1	550X260X540	-	1	12	20
FO075025A	27	59,5	560X350X560	-	1	12	20
FO075031O	21	46	550X260X540	-	1	12	20
FO075018B	21	46	550X260X540	-	1	12	20
WITH HOSE							
FO075002B	26	57,3	550X260X540	-	1	12	20
FO075003B	25	55,1	550X260X540	-	1	12	20
FO075023B	18	39,7	550X260X540	-	1	12	20
FO075004B	22	49,5	550X260X540	-	1	12	20
FO075012B	22	49,5	550X260X540	-	1	12	20
FO075024B	18	39,7	550X260X540	-	1	12	20
FO075009B	19	41,9	550X260X540	-	1	12	20
FO075010B	27	59,5	550X260X540	-	1	12	20
FO075019B	27	59,5	560X350X560	-	1	8	12
FO075026B	27	59,5	560X350X560	-	1	8	12
FO075013B	23	50,7	550X260X540	-	1	12	20



HOSE REELS



ACCESSORIES



MERCHANDISE



INDEX



AIR



ANTIFREEZE



AdBlue®



BIODIESEL



DIESEL



FOOD



GASOLINE



GREASE



KEROSENE



OIL



WATER



WINDSCREEN

INSTALLATION&DIMENSIONS

Different ways to install PIUSI's hose reels: they can be easily placed wherever you need them without any problem about functionality and safety. PIUSI's products are without a doubt designed to support your work in any condition.

ROOF INSTALLATION

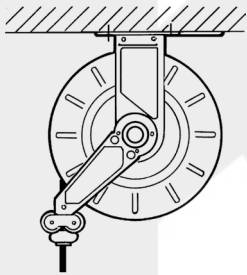

WALL INSTALLATION

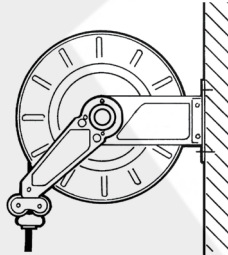

GROUND INSTALLATION

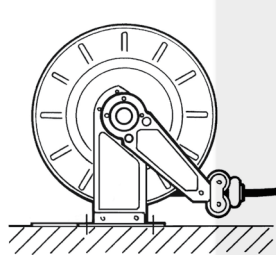

MODEL HOSE REEL XL HOSE REEL BIG HOSE REEL SMALL

A	512	495	475
B	470	460	460
C	227	152	102
D	200	200	150
E	322	246	196
F	160	150	150
G	260	200	150
H	12	12	12
L	382	306	256

HOSE REEL FRONT / SIDE

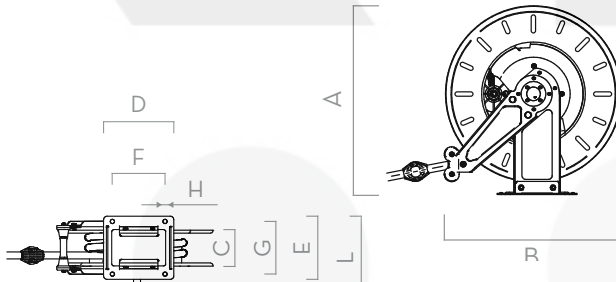

Dimensions expressed in millimeters

IN THE BOX

- REEL
- WALL MOUNT BRACKET
- INSTRUCTION MANUAL

DETAILS



4 ROLLS HOSE GUIDE



AUTOMATIC HOSE REELS

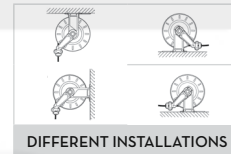

DIFFERENT INSTALLATIONS



STURDY DESIGN

MATERIALS

- BODY: CAST IRON
- HUB: SYNTHETIC STEEL
- TUBE: RUBBER

TECHNICAL DATA

CODE	DESCRIPTION	FLUIDS TYPE	HOSE* BPS	MAX OPERATING PRESSURE		PRESSURE DROP TYPE	INLET WITH SWIVEL BSP	OUTLET HOSETAIL BSP	HOSE MAX LENGTH BOUND* METERS	HOSE LENGTH METER
				BAR						
WITHOUT HOSE										
FO075000A	HOSE REEL 3/4" BIG	D	3/4"	10		0,15 @ 60 L/MIN	1" MALE	3/4"	14	-
FO075001A	HOSE REEL 1" BIG	D	1"	10		0,2 @ 80 L/MIN	1" MALE	1"	10	-
FO075008A	HOSE REEL 3/4" SMALL	D	3/4"	10		0,15 @ 60 L/MIN	1" MALE	3/4"	10	-
FO075025A	HOSE REEL 1" XL HEAVY DUTY**	D	1"	15		0,5 @ 80 L/MIN	1" FEMALE	1" MALE	15	-
FO0750310	HOSE REEL NAKED XL 20M	D	3/4"	10		0,15 @ 60 L/MIN	1" FEMALE	3/4" MALE	20	-
FO075018B	HOSE REEL NAKED XL 15M	D G	1"	10		0,2 @ 80 L/MIN	1" FEMALE	1" MALE	15	-
WITH HOSE										
FO075002B	HOSE REEL 8X1" BIG	D	1"	10		0,6 @ 80 L/MIN	1" FEMALE	1" MALE	-	8
FO075003B	HOSE REEL 10X1" BIG	D	1"	10		0,7 @ 80 L/MIN	1" FEMALE	1" MALE	-	10
FO075023B	HOSE REEL 10X1" BIG HEAVY DUTY**	D	1"	10		0,7 @ 80 L/MIN	1" FEMALE	1" MALE	-	10
FO075004B	HOSE REEL 10X3/4" BIG	D	3/4"	10		0,7 @ 60 L/MIN	1" FEMALE	1" MALE	-	10
FO075012B	HOSE REEL 10X3/4" BIG	D	3/4"	10		0,7 @ 60 L/MIN	1" FEMALE	3/4" MALE	-	10
FO075024B	HOSE REEL 10X3/4" BIG HEAVY DUTY**	D	3/4"	10		0,9 @ 60 L/MIN	1" FEMALE	1" MALE	-	10
FO075009B	HOSE REEL 8X3/4" SMALL	D	3/4"	10		0,6 @ 60 L/MIN	1" FEMALE	1" MALE	-	8
FO075010B	HOSE REEL 14X3/4" BIG	D	3/4"	10		0,6 @ 60 L/MIN	1" FEMALE	1" MALE	-	14
FO075019B	HOSE REEL 15X1" XL	D	1"	15		1 @ 80 L/MIN	1" FEMALE	1" MALE	-	15
FO075026B	HOSE REEL 15X1" XL HEAVY DUTY**	D	1"	15		0,8 @ 80 L/MIN	1" FEMALE	1" MALE	-	15
FO075013B	HOSE REEL 10 X 3/4" BIG GASOLINE	D	3/4"	15		0,7 @ 80 L/MIN	1" FEMALE	1" MALE	-	10

*MINIMUM RADIUS OF CURVATURE FOR 3/4 HOSE SIZES "AND 1" OF AT LEAST 130MM; ELECTRICALLY, THE HOSE MUST BE CONDUCTOR R-1 MOhm/m

**STEEL HUB

DIESEL HOSE REEL

OPEN

161



HOSE REELS

ACCESSORIES

DIESEL OPEN

DIESEL HOSE REEL	CODE	DESCRIPTION
	F1629800A	BIG HOSE REEL FIXED BASE
	F1731600A	SMALL HOSE REEL FIXED BASE
	F1627900A	BIG HOSE REEL ROTATING SUPPORT
	F1731700A	SMALL HOSE REEL ROTATING SUPPORT
	F16367000	DIESEL HOSE Ø25 L=1M CRIMPED 1"X1"



F1629800A F1627900A
F1731600A F1731700A F16367000





KKD

ACCESSORIES

FILTER



DISPENSERS



PUMPS



METERS



NOZZLE



FILTRATION



FLUID MONITORING

CONNECTORS

FEATURES

- STURDY STRUCTURE
- READY TO USE
- SEVERAL SOLUTIONS AVAILABLE

The range of fuel products is completed with a wide array of accessories for connecting products to allow the best performance. Starting form the 2" connectors and quick coupling.

PERFORMANCE

2"

DRUM CONNECTOR

2"

QUICK COUPLING



2" DRUM CONNECTOR WITHOUT INTEGRATED VALVE



2" DRUM CONNECTOR WITH FLANGED AND INTEGRATED VALVE



2" DRUM CONNECTOR WITH INTEGRATED VALVE



2" QUICK COUPLING

PACKAGING

CODE	PACKAGING			
	KG	MM	INCH	PCS/BOX
2" CONNECTOR				
F17163000	0,6	133X98X85	-	1
F17190000	0,6	133X98X85	-	1
F17163010	0,8	133X98X85	-	1
2" QUICK COUPLING				
RO9160000	0,9	133X98X85	-	1
RO8930000	0,9	133X98X85	-	1



HOSE REELS



ACCESSORIES



MERCHANDISE



AIR



ANTIFREEZE



AdBlue®



BIODIESEL



DIESEL



FOOD



GASOLINE



GREASE



KEROSENE



OIL



WATER



WINDSCREEN

CHART

EXTENSIBLE SUCTION STEEL KIT (1800MM) COMPOSED BY:

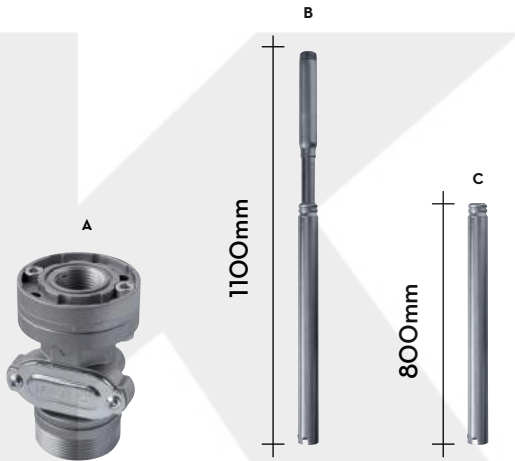

A: DRUM CONNECTOR FLANGED AND VALVE

B: EXTENSIBLE STEEL PIPE 1" BSP

C: STEEL PIPE 1" BSP

CODE: F008934010

WEIGHT: 3,9 KG

PACKAGING: 820X150X100

IN THE BOX

- CONNECTOR
- INSTRUCTION MANUAL

DETAILS



MESH STRAINER



INTEGRATED VALVE

DIMENSIONS

EXTENSIBLE PIPE PLASTIC MADE



EXTENSIBLE STEEL PIPE 1" BSP



2" CONNECTOR



2" QUICK CONNECTOR

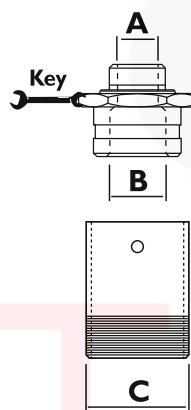

Dimensions expressed in millimeters

MATERIALS

- STEEL

TECHNICAL DATA

CODE	DESCRIPTION	FLUIDS TYPE	INTEGRATED VALVE	FILTER	INLET	OUTLET	THREADED FLANGE	A	B	C	D	KEY
					BSP	BSP	BSP	BSP	BSP	BSP	MM	
2" CONNECTOR												
F17163000	DRUM CONNECTOR WITH INTEGRATED VALVE	D G K O	YES	YES	2"	-	NO	1"	1"	2"	62	-
F17190000	DRUM CONNECTOR WITHOUT INTEGRATED VALVE	D G K O	NO	YES	2"	-	NO	1"	1"	2"	62	-
F17163010	DRUM CONNECTOR WITH FLANGED AND INTEGRATED VALVE	D G K O	YES	YES	2"	1"	YES	1"	1"	2"	62	-
2" QUICK COUPLING												
R09160000	QUICK COUPLING 3/4"	D O	NO	NO	3/4"	1"	NO	M 3/4"	F 1"	M 2"	1	60
R08930000	QUICK COUPLING 1"	D O	NO	NO	1"	1"	NO	M 1"	F 1"	M 2"	1	60



DISPENSERS



PUMPS



METERS



NOZZLE



FILTRATION

FLUID
MONITORING

COUPLING & FITTINGS

FEATURES

- EASY TO USE
- VERSATILITY AND SEVERAL SHAPES

PIUSI coupling & fittings are engineered to fit every application context representing the perfect solution to connect the fuel equipment.

TECHNICAL DATA

CODE	DESCRIPTION	INLET / OUTLET			KEY		Q.TY
		A	B	C	1	2	

ELBOWS

FO7806000	ELBOWS	F 3/4" BSP	F 3/4" BSP	-	-	-	-
FO7805000	ELBOWS	M 3/4" BSP	F 3/4" BSP	-	-	-	-
FO8609000	ELBOWS	F 1" BSP	F 1" BSP	-	-	-	-
FO7988000	ELBOWS	M 1" BSP	F 1" BSP	-	-	-	-
FO7988000	INOX ELBOWS	M 1" BSP	F 1" BSP	-	-	-	-
F14567000	ELBOW ROTATING CONNECTOR	M 1" BSP	F 1" BSP	-	-	-	-



ELBOW ROTATING CONNECTOR



ELBOWS

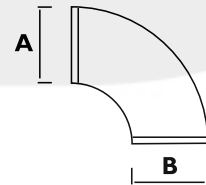

HOSE TAILS

FO826700A	HOSE TAILS	1/2" BSP	19 MM	-	24	-	1
FO643700A	HOSE TAILS	3/4" BSP	19 MM	-	32	-	20
FO776800B	HOSE TAILS	3/4" BSP	25 MM	-	32	-	20
FO775700A	HOSE TAILS	1" BSP	19 MM	-	37	-	20
FO776400A	HOSE TAILS	1" BSP	25 MM	-	37	-	20
F14122000	INOX HOSE TAILS	M 1" BSP	19 MM	-	37	-	1
F14123000	INOX HOSE TAILS	F 3/4" BSP	19 MM	-	37	-	1

ROTATING HOSE TAILS - INOX

F14132000	INOX ROTATING HOSE TAIL	3/4" BSP	19 MM	-	27	-	-
-----------	-------------------------	----------	-------	---	----	---	---



HOSE TAILS

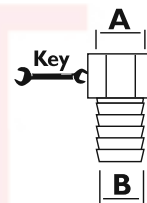
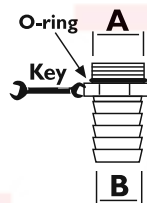
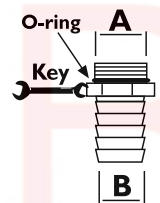

HOSE TAILS INOX VERSION

ROTATING HOSE TAILS
INOX VERSION

HQC

		KG.	MM.	PCS/BOX
FO0636000	HQC HOSE QUICK COUPLING 1"	0,46	80X80X75	1



HOSE QUICK COUPLING CLOSED



HOSE QUICK COUPLING OPEN

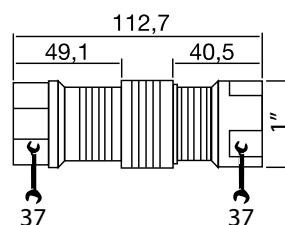



HOSE REELS



ACCESSORIES



MERCHANDISE

PIUSI[®]

INDEX



AIR



ANTIFREEZE



AdBlue[®]



BIODIESEL



DIESEL



FOOD



GASOLINE



GREASE



KEROSENE



OIL



WATER



WINDSCREEN

TECHNICAL DATA

CODE	DESCRIPTION	INLET / OUTLET			KEY		Q.TY
		A	B	C	1	2	

SLEEVE

FO8137000	SLEEVE	28 MM	20 MM	-	30	-	-
FO8138000	SLEEVE	36 MM	28 MM	-	35	-	-

SLEEVE

FO7766000	SLEEVE	M 3/4" BSP	M 3/4" BSP	-	27	-	-
FO7765000	SLEEVE	M 1" BSP	M 1" BSP	-	34	-	-



SLEEVE

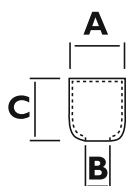

SLEEVE

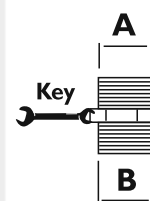

REDUCING SOCKETS

FO7441000	REDUCING SOCKETS	F 1/2" BSP	M 3/4" BSP	-	30	-	-
FO7762000	REDUCING SOCKETS	M 3/4" BSP	M 1" BSP	-	34	-	-
FO8913000	REDUCING SOCKETS	M 1" BSP	M 1" 1/2" BSP	-	50	-	-
FO7760000	REDUCING SOCKETS	F 3/4" BSP	M 1" BSP	-	53	-	-
FO7889000	REDUCING SOCKETS	F 1" BSP	M 3/4" BSP	-	34	-	-
OO8891000	REDUCING SOCKETS	F 1" BSP	M 2" BSP	-	60	-	-



REDUCING SOCKETS

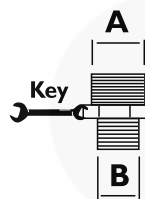

SEALANT PASTE

		GR.	ML.	QUANTITY
FO8173000	LIGHT REMOVABLE	130	-	1
F10767000	MEDIUM REMOVABLE		250	1
F12278000	HEAVY NON REMOVABLE		250	1



SEALANT PASTE

SWIVEL: UNION, RE-USABLE COUPLING

OO0890000	UNION 34.27	3/4" BSP	19 MM	27 MM	38 MM	38 MM	-
OO0891000	UNION 1.27	1"	19 MM	27 MM	31 MM	31 MM	-
OO0892000	UNION 1.35	1"	25 MM	35 MM	38 MM	38 MM	-
OO0893000	UNION 34.32	3/4"	19 MM	32 MM	31 MM	31 MM	-
OO0894000	UNION 1.32	1"	19 MM	32 MM	38 MM	38 MM	-
OO0895000	UNION 1.38	1"	25 MM	38 MM	38 MM	38 MM	-



UNION



1



2



3



4

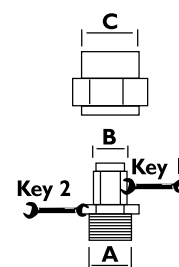



DISPENSERS



PUMPS



METERS



NOZZLE



FILTRATION

FLUID
MONITORING

FLANGED CONNECTIONS

FEATURES

- STURDY DESIGN
- EASY TO FIT
- SEVERAL SHAPES

Safe and guaranteed solutions to connect products: connections, elbows, full kits and flanges.

TECHNICAL DATA

CODE	DESCRIPTION	INLET / OUTLET				FLANGE N°	O-RING N°	OVAL RING N°	SCREW		GRUB SCREW M8X50 N°	NUT M8 N°
		A	B	C	H				M8X20 N°	M8X30 N°		

FLANGE

FO8832000	FLANGE	-	1" BSP	80 MM	18 MM	-	-	-	-	-	-	-
-----------	--------	---	--------	-------	-------	---	---	---	---	---	---	---

FLANGE KIT

R12904000	KIT FLANGE OVAL RING	-	-	-	-	1	-	1	2	-	2	-
RO9180000	KIT FLANGE O-RING	-	-	-	-	2	2	-	4	-	-	-
R1106200A	KIT FLANGE	-	-	-	-	1	1	-	2	-	-	-
R12906000	KIT FLANGE WITH NUT	-	-	-	-	1	-	-	-	-	2	-
RO977900A	KIT FLANGE TO CONNECT METER	-	-	-	-	1	2	-	-	-	2	2
FO8832000	FLANGE	-	-	-	-	1	-	-	-	-	-	-
RO8985000	OVAL RING	-	-	-	-	-	-	1	-	-	-	-
RO8417000	O-RING	-	-	-	-	-	2	-	-	-	-	-
FO881200A	SCREW M8X20	-	-	-	-	-	-	-	10	-	-	-
FO8043000	SCREW M8X30	-	-	-	-	-	-	-	-	10	-	-
F19271000	KIT FLANGE TO CONNECT FILTER	-	-	-	-	1	1	1	-	2	2	-



FLANGE

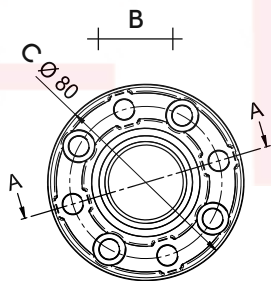

SEZIONE A-A

1" BSP

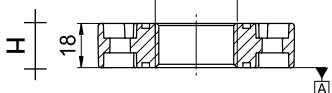

SCREW



NUT



FLANGE



O-RING



OVAL RING



GRUB SCREW

FLANGE KIT





HOSE REELS



ACCESSORIES



MERCHANDISE



AIR



ANTIFREEZE



AdBlue®



BIODIESEL



DIESEL



FOOD



GASOLINE



GREASE



KEROSENE



OIL



WATER



WINDSCREEN

TECHNICAL DATA

CODE	DESCRIPTION	INLET / OUTLET				FLANGE	O-RING	OVAL RING	SCREW		GRUB SCREW	NUT
		A	B	C	H	N°	N°	N°	M8X20 N°	M8X30 N°	M8X50 N°	M8 N°

FLANGED CONNECTIONS

R12172000	FLANGED TUBE 341	341	67	-	-	-	-	-	-	-	-	-
R12229000	FLANGED TUBE 130	130	67	-	-	-	-	-	-	-	-	-
R1222800A	FLANGED TUBE 300	300	67	-	-	-	-	-	-	-	-	-
R13251000	FLANGED TUBE 205	205	54,7	44,3	-	-	-	-	-	-	-	-

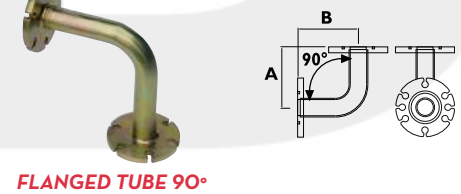

FLANGED ELBOW

R10824000	FLANGED ELBOW	-	-	-	-	-	2	-	2	2	-	2
-----------	---------------	---	---	---	---	---	---	---	---	---	---	---

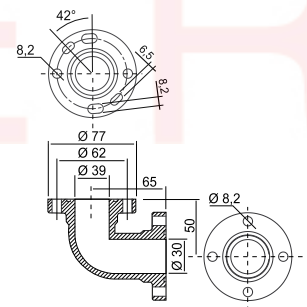



DISPENSERS



PUMPS



METERS



NOZZLE



FILTRATION

FLUID
MONITORING

HOSE & SWIVEL

Diesel fuel delivery hoses, suction hoses, crimped hoses, rotating hose connectors: a wide range to complete the accessories product range.

TECHNICAL DATA

CODE	DESCRIPTION	FLUIDS TYPE	PRESSURE		VACUUM	DIMENSIONS				KEY	CAMLOCK MALE/FEMALE BSP
			BAR	PSI		A MM	B MM	S MM	L M/FT.		

DISPENSING HOSES

FO060502A	RUBBER HOSE 80 METERS	D	10	-	-	20	27	-	80	-	-
FO060602A	RUBBER HOSE 40 METERS	D	10	-	-	25	35	-	40	-	-

SUCTION HOSES

FO8870000	CARBUREX	D	10	-	-0,9	25	33	-	50	-	-
F12120010	SPIRAL RUBBER HOSE 60 METERS	D B O	10	-	-0,9	25	35	-	60	-	-
F1113100B	PVC HOSE 60 METERS	D O	10	-	-0,9	25	33	-	60	-	-

DISPENSING CRIMPED HOSES

F11885000	CRIMPED HOSE	D	10	-	-	3/4" BSP	3/4" BSP	20	4	-	-
FO8561000	CRIMPED HOSE	D	10	-	-	3/4" BSP	1" BSP	20	4	-	-
FO8976000	CRIMPED HOSE	D	10	-	-	1" BSP	1" BSP	20	4	-	-
F12876000	CRIMPED HOSE	D	10	-	-	3/4" BSP	3/4" BSP	20	6	-	-
F11063000	CRIMPED HOSE	D	10	-	-	3/4" BSP	1" BSP	20	6	-	-
FO8945000	CRIMPED HOSE	D	10	-	-	1" BSP	1" BSP	20	6	-	-
F11060000	CRIMPED HOSE	D	10	-	-	1" BSP	1" BSP	20	7	-	-
F12323000	CRIMPED HOSE	D	10	-	-	1" BSP	1" BSP	20	8	-	-
F11532000	CRIMPED HOSE	D	10	-	-	3/4" BSP	1" BSP	20	10	-	-
F12929000	CRIMPED HOSE	D	10	-	-	1" BSP	1" BSP	20	10	-	-
O11904000	CRIMPED HOSE	D	10	-	-	1" BSP	1" BSP	25	1,2	-	-
F12794000	CRIMPED HOSE	D	10	-	-	1" BSP	1" BSP	25	2	-	-
FO8560000	CRIMPED HOSE	D	10	-	-	1" BSP	1" BSP	25	3	-	-
FO8977000	CRIMPED HOSE	D	10	-	-	1" BSP	1" BSP	25	4	-	-
F11264000	CRIMPED HOSE	D	10	-	-	1" BSP	1" BSP	25	5	-	-
FO8858000	CRIMPED HOSE	D	10	-	-	1" BSP	1" BSP	25	6	-	-
F12784000	CRIMPED HOSE	D	10	-	-	1" BSP	1" BSP	25	7	-	-
F11540000	CRIMPED HOSE	D	10	-	-	1" BSP	1" BSP	25	8	-	-
F12785000	CRIMPED HOSE	D	10	-	-	1" BSP	1" BSP	25	10	-	-
F14412000	CRIMPED HOSE	D	10	-	-	1" BSP	1" BSP	25	12	-	-



DISPENSING HOSES



RUBBER HOSE



RUBBER SUCTION HOSE



PVC HOSE

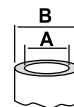

CRIMPED HOSE

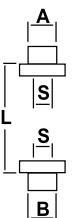



HOSE REELS



ACCESSORIES



MERCHANDISE



AIR



ANTIFREEZE



AdBlue[®]



BIODIESEL



DIESEL



FOOD



GASOLINE



GREASE



KEROSENE



OIL



WATER



WINDSCREEN

TECHNICAL DATA

CODE	DESCRIPTION	FLUIDS TYPE	PRESSURE		VACUUM	DIMENSIONS				KEY	CAMLOCK
			BAR	PSI		A MM	B MM	S MM	L M/FT.		

HOSE KIT 1" 1/2

F18798000	KIT HOSE 1" 1/2	D	10	145	-	1" 1/2 BSP	-	-	-	-	1" 1/2 BSP
F18799000	KIT HOSE 1" 1/2	D	20	65,6	-	1" 1/2 BSP	-	-	-	-	1" 1/2 BSP



HOSE KIT 1" 1/2



CAMLOCK

SUCTION CRIMPED HOSES - RUBBER HOSES

F12117000	RUBBER HOSE	D B O	10	-	-0,9	1" BSP	1" BSP	25	1	-	-
F12118000	RUBBER HOSE	D B O	10	-	-0,9	1" BSP	1" BSP	25	1,5	-	-
F12119000	RUBBER HOSE	D B O	10	-	-0,9	1" BSP	1" BSP	25	2	-	-
F13768000	RUBBER HOSE	D B O	10	-	-0,9	1" BSP	1" BSP	25	3,5	-	-
F13695000	RUBBER HOSE	D B O	10	-	-0,9	1" BSP	1" BSP	25	5	-	-

SUCTION CRIMPED HOSES - SPIRAL RUBBER HOSES

F1640400A	SPIRAL PVC HOSE + FOOT VALVE WITH FILTER	D B O	10	-	-0,9	1" BSP	1" BSP	25	4	-	-
-----------	--	-------	----	---	------	--------	--------	----	---	---	---

SUCTION CRIMPED HOSES - SPIRAL PVC HOSES

F1113200A	SPIRAL PVC HOSE + FOOT VALVE WITH FILTER	D O	10	-	-0,9	1" BSP	1" BSP	25	1,6	-	-
F11638010	SPIRAL PVC HOSE + FOOT VALVE WITH FILTER	D O	10	-	-0,9	1" BSP	1" BSP	25	4	-	-



RUBBER HOSE



SPIRAL RUBBER HOSE



SPIRAL PVC HOSE

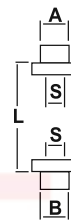

SWIVEL

F0845600A	SWIVEL 12.12	-	-	-	-	M 1/2" BSP	F 3/4" BSP	-	-	25	-
FO062000A	SWIVEL 34.1	-	-	-	-	M 3/4" BSP	F 1" BSP	-	-	94	-
FO062200A	SWIVEL 1.1 MF	-	-	-	-	M 1" BSP	F 1" BSP	-	-	38	-
OO0623000	SWIVEL 34.1 MM	-	-	-	-	M 3/4" BSP	M 1" BSP	-	-	34	-
OO062400A	SWIVEL 34.34 MM	-	-	-	-	M 3/4" BSP	F 3/4" BSP	-	-	34	-



ROTATING SWIVEL



ROTATING HOSE CONNECTORS

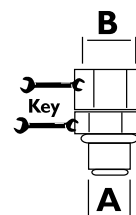



KKD

MERCHANDISE

FILTER





DISPENSERS



PUMPS



METERS



NOZZLE



FILTRATION



FLUID MONITORING

MERCHANDISE



PACKAGING

CODE	DESCRIPTION	WEIGHT		PACKAGING			
		KG	LBS	MM	INCH	PCS/PALLET	PCS/BOX
T-SHIRT BLACK							
PBG000031	PIUSI T-SHIRT BLACK BOX 10 PCS - L	1	-	35X26X18	-	-	10
PBG000032	PIUSI T-SHIRT BLACK BOX 10 PCS - XL	1	-	35X26X18	-	-	10
T-SHIRT WHITE							
PBG000026	PIUSI T-SHIRT WHITE BOX 10 PCS - L	1	-	35X26X18	-	-	10
PBG000027	PIUSI T-SHIRT WHITE BOX 10 PCS - XL	1	-	35X26X18	-	-	10
PBG000029	PIUSI T-SHIRT WHITE BOX 10 PCS - M	1	-	35X26X18	-	-	10



HOSE REELS



ACCESSORIES



MERCHANDISE

PIUSI[®]

INDEX



PACKAGING

CODE	DESCRIPTION	WEIGHT		PACKAGING			
		KG	LBS	MM	INCH	PCS/PALLET	PCS/BOX
CROWNER							
PBA000013	PIUSI METALLIC FLOOR STAND	76	-	120X100 (PALLET)	-	1	-
POSTER							
PBPO00003	KIT POSTERS PIUSI - BOX 10 PCS	0,2	-	70X12	-	-	10
UMBRELLA							
PBG000030	PIUSI UMBRELLA - BOX 10 PCS	5,5	-	35X26X18	-	-	10
BAG							
PBG000035	PIUSI BAG 2018 - BOX 150 PCS	18,5	-	-	-	-	150

NOTES

KID

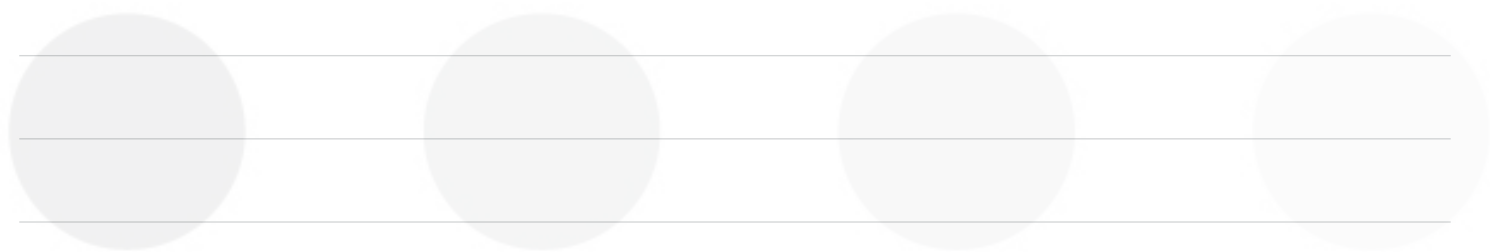

FILTER

KID

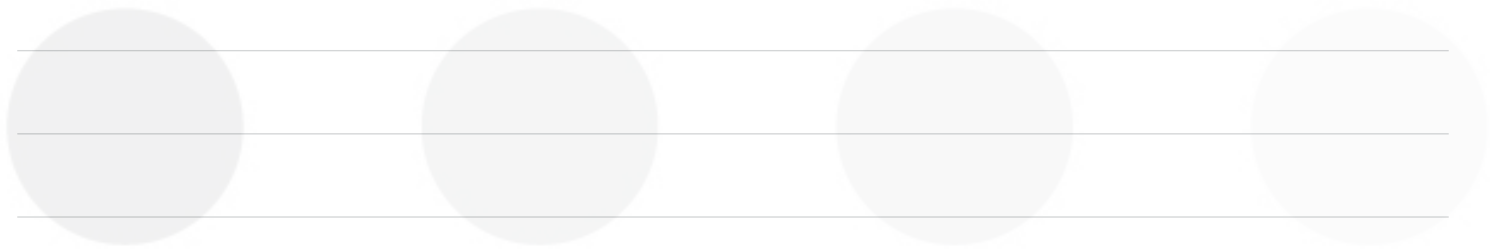

FILTER

NOTES

KID

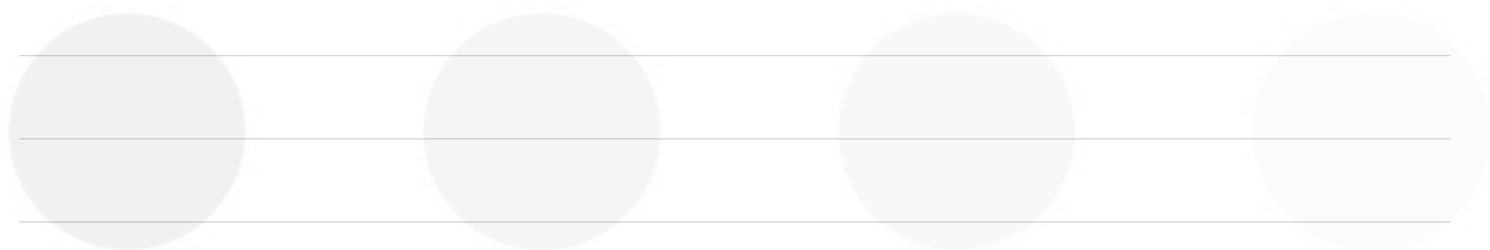

FILTER

KID

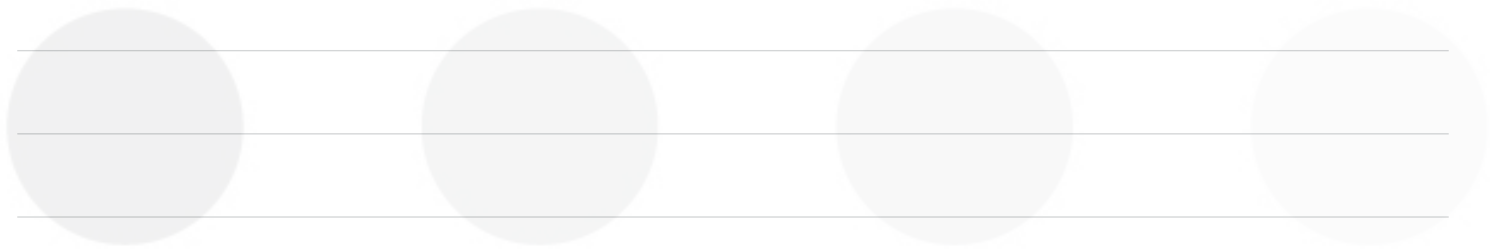

FILTER

PIUSI FLUIDS' INFORMATION

ATEX/IECEX DIRECTIVE

SAFETY IN EXPLOSIVE ENVIRONMENTS

As of 1st July 2003, the ATEX directive came into force throughout the EEC. This directive became an obligatory requirement for all electrical and mechanical equipment intended for use in dangerous areas. Potentially explosive atmospheres exist where there is a risk of explosion due to mixtures of gas and air, steam and air, dust and air or other flammable combinations typical of petrol vapours.

If the electrical or mechanical material must be used in areas where there is an explosive atmosphere, it must be designed and built so as not to create/ to eliminate sources of ignition such as sparks, hot surfaces or static electricity and all sources of combustion able to ignite these mixtures. Risk areas for environments where gas and flammable vapours are present can range from AREA 0 (constant risk of explosion) to AREA 1 (risk of explosion probable) and AREA 2 (low risk and any risk of explosion persists for a short time only).

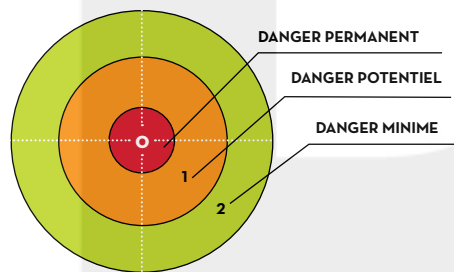

OUR PUMPS COMPLIES WITH THE FOLLOWING MARKING ATEX/IECEX

II	2	G	Ex	d	IIA	T4	Gb
GROUP	CATEGORY	TYPE OF EXPLOSIVE ATMOSPHERE	PERMANENT PREFIX	PROTECTION METHOD	GAS GLASS	TEMPERATURE CLASS	EQUIPMENT PROTECTION LEVEL

II = Group II comprises appliances intended for use in other environments (other than mining) in which explosive atmospheres are probable.

2 = High protection, Category 2 for AREA 1 GAS and AREA 2 GAS

G = Gas

Ex = Explosion-proof equipment certified according to the European ATEX directives

d = Explosion-proof cases (EN 60079-1)

IIA = Electrical appliances for potentially explosive environments other than mining. (Propane, Butane etc.)

T4 = The temperature of the pump will not exceed 135°C

PIUSI 'S EXPERIENCE IN THE WORLD OF FLAMMABLE LIQUIDS

Piusi renews his natural propension to find solutions for the transfer of fluids, expanding its range with new products to dispensing flammable liquids.

Experience gained with pumps for transferring diesel fuel, combined with the growing demands of the market, have fostered the development of this new range of pumps for gasoline, kerosene and diesel, that satisfy the criteria of strict ATEX directives concerning the use of materials in potentially explosive atmospheres.

The Piusi products have successfully obtained certification CESI and IECEX Certificate of Conformity.



TYPE OF FLUIDS

AIR
A
ANTIFREEZE
A
AdBlue® (UREA)
Ad
BIODIESEL (B20)
B
DIESEL
D
FOOD
F
GASOLINE
G
GREASE
G^R
KEROSENE
K
OIL
O
WATER
W
WINDSCREEN
W_S

The intellectual property of this catalogue is assigned to all countries. Translation, reproduction, electronic storage and full or partial adaption by any means (including microfilms and photocopies) of its contents, without prior written authorisation from Piusi S.p.a., entails a violation of PIUSI S.P.A.'s copyrights and constitutes an act of unfair competition. The products shown in the images of this catalogue are protected according to the regulation in force regarding industrial property. The information contained in this catalogue is as accurate as possible and complies, as far as possible, with existing regulations at the time of its publication. We therefore reserve the right to make subsequent modifications in line with modifications to regulations and/ or in relation to any production requirements that are deemed necessary for safety reasons. The technical specifications indicated in this catalogue cancel out and replace those already present in the previous general catalogue and in the product catalogues. The updates and product data sheets are available in PDF format on our website: www.piusi.com



PIUSI

CERTIFIED
ISO 9001 / ISO 14001

SINCE 1953, PIUSI HAS BEEN EMPLOYING ITALIAN ENGINEERING SKILLS AT THE SERVICE OF ITS CUSTOMERS, WITH PROFESSIONALISM AND INTEGRITY IN ORDER TO BUILD STABLE AND LASTING RELATIONSHIPS.

OUR MISSION IS TO PROVIDE SIMPLE, INTELLIGENT AND PROFESSIONAL SOLUTIONS FOR THE TRANSFER, DISPENSE AND MEASUREMENT OF LUBRICANTS, FUELS AND LIQUIDS, WITH THE HIGHEST CONSIDERATION FOR HUMAN AND ENVIRONMENTAL HEALTH.



*PIUSI S.p.A.
Headquarters
46029 Suzzara (Mantova) Italy
tel.+39 0376 534561
fax.+39 0376 536393
e-mail: piusi@piusi.com
www.piusi.com*



*PIUSI USA, Inc.
3901 Anglers Avenue
Fort Lauderdale, FL 33312
tel.: 954 584 1552
fax.: 954 584 1554
Email: piusiusa@piusiusa.com
www.piusiusa.com*